

AVENUE

Avenue™ signal integration system

Model 6010 Four Channel 20-Bit Audio ADC Data Pack

GRAHAM-PATTEN
The sound choice.

Revision 3.1 SW v1.0.0

This data pack provides detailed installation, configuration and operation information for the **Model 6010 Four Channel 20-bit Audio Analog to Digital Converter (ADC)** module as part of the Avenue Signal Integration System.

The module information in this data pack is organized into the following sections:

- Module Overview
- Applications
- Installation
- Cabling
- Module Configuration and Control
 - Front Panel Controls and Indicators
 - Avenue PC Remote Control
 - Avenue Touch Screen Remote Control
- Troubleshooting
- Software Updating
- Warranty and Factory Service
- Specifications

MODULE OVERVIEW

The 6010 Four Channel 20-bit Analog to Digital Converter (ADC) converts four channels of analog audio to two AES digital audio streams. Analog to digital conversion is performed with 20-bit precision.

As shown in the block diagram below, four high impedance balanced analog audio inputs enter the module on a high density 15-pin connector. The signals are buffered and passed through gain adjustment circuitry before being converted to digital audio and sent to two AES outputs (four copies of each) on rear BNC connectors. The ADC sample clocks may be locked to an internal 48 kHz crystal controlled sample rate clock or locked to an external AES3id reference from a BNC on the rear backplane.

Front panel indicators are provided for monitoring the external AES reference and the four input channels of analog audio as well as power and CPU status.

Control of the module can be from one of the remote Avenue options or from the local controls on the front of the module. Adjustments on the module include a rotary control to set the analog input reference level and a set of switches to set the digital output reference level. (Both of these reference levels determine the analog input gain.) The on-board microprocessor communicates with the frame for remote control via the Avenue System Control module if installed. Module ID (slot location, software version and board revision) and status information can be monitored by the frame System Control module and read using the optional interfaces available. Alarms can also be enabled if desired.

Power is derived from the ± 12 volt frame power. It is regulated to the required voltages for the module by on-board regulators. The module is fused with resettable fuse devices. If a fuse opens due to an overcurrent condition, the module will lose power. After pulling the module, the fuse will reset automatically requiring no replacement fuse.

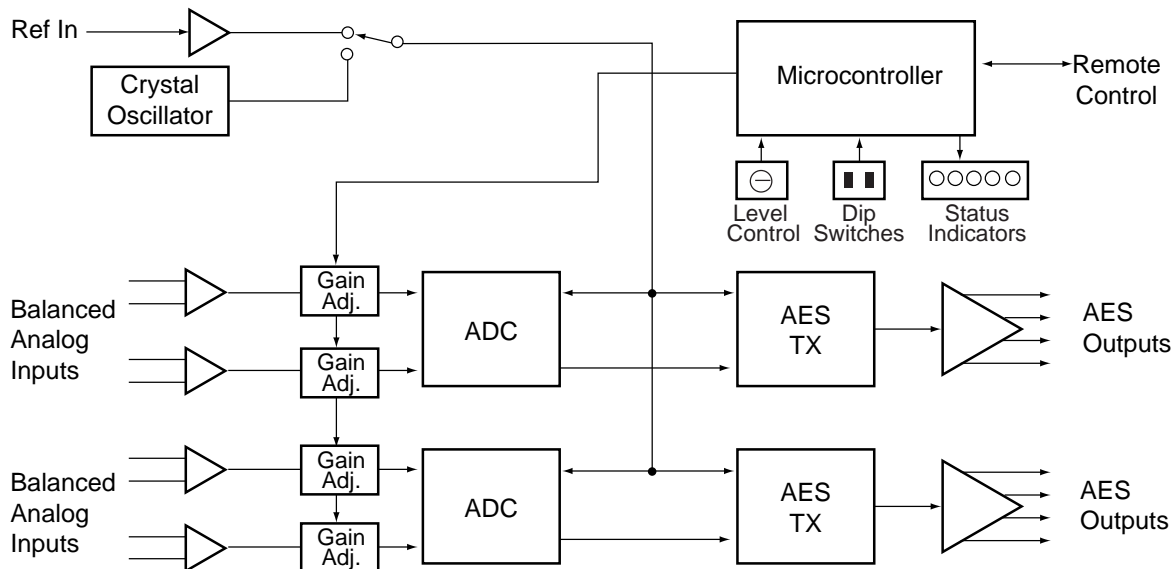

6010 Four Channel 20-bit Audio ADC Functional Block Diagram

APPLICATIONS

Converting Analog VTR Audio Output to Digital

In the application shown below, a 6010 module converts the audio outputs of an analog VTR to digital. Note that a 6030 Video Referenced AES/Word Clock Generator module provides an AES clock reference for the 6010 module. In most video applications, it is essential that AES sample clocks be locked to a video reference. Note also that the 6010 provides four copies of each AES output.

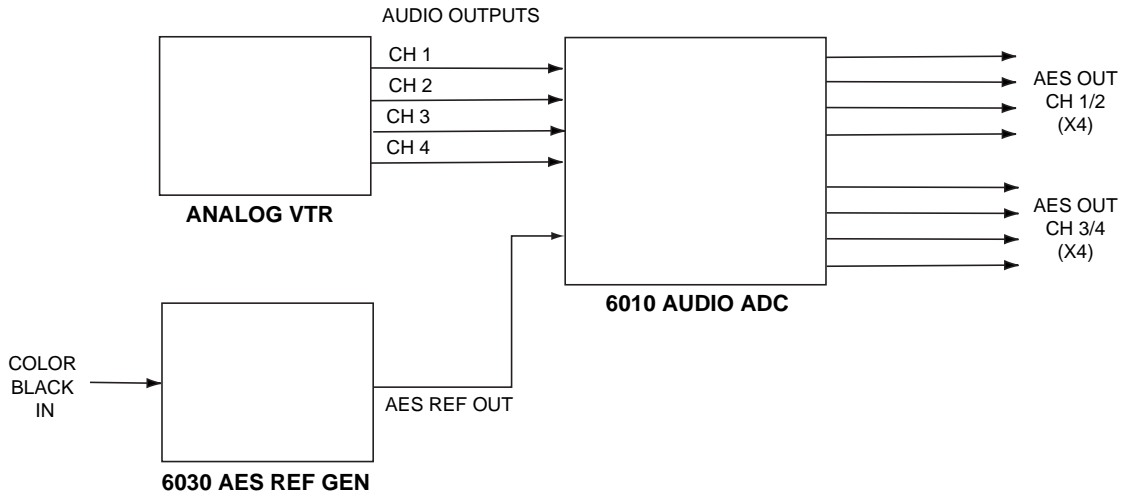

6010 Conversion of Analog VTR Audio Output to Digital

Analog Conversion from Video Routing Switcher to Feed Digital VTR

In this application, a 6010 module converts four channels of analog audio from a video routing switcher to digital to feed a digital VTR. A 6030 Video Referenced AES/Word Clock Generator module provides a video-locked AES reference for the 6010 module.

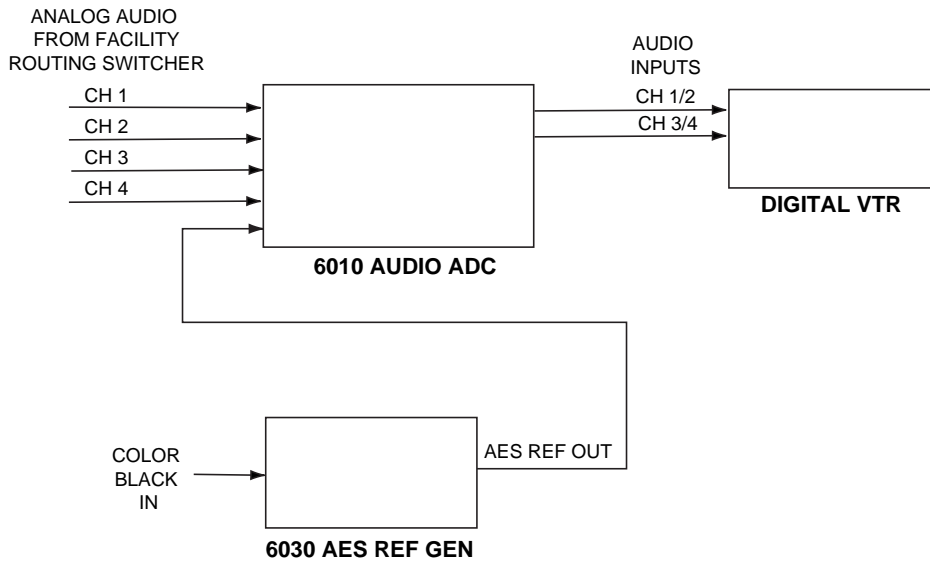

Converting Routing Switcher Analog Audio to Digital

Converting Audio Outputs of Two Independent 2-Track Analog Tape Recorders

Even though it is a four channel device, the 6010 utilizes two separate 2-channel A/D converters. In this application, a 6010 module converts the audio outputs of two independent 2-track analog audio tape recorders to digital. Care should be exercised when connecting the audio inputs to the 6010 to ensure that one machine is connected to inputs 1 and 2 and the other machine to inputs 3 and 4. This will ensure that the outputs of the two machines will be paired correctly on the AES outputs of the 6010. Use of a 6030 module to provide a video-locked AES reference for the 6010 is optional and is recommended in video applications.

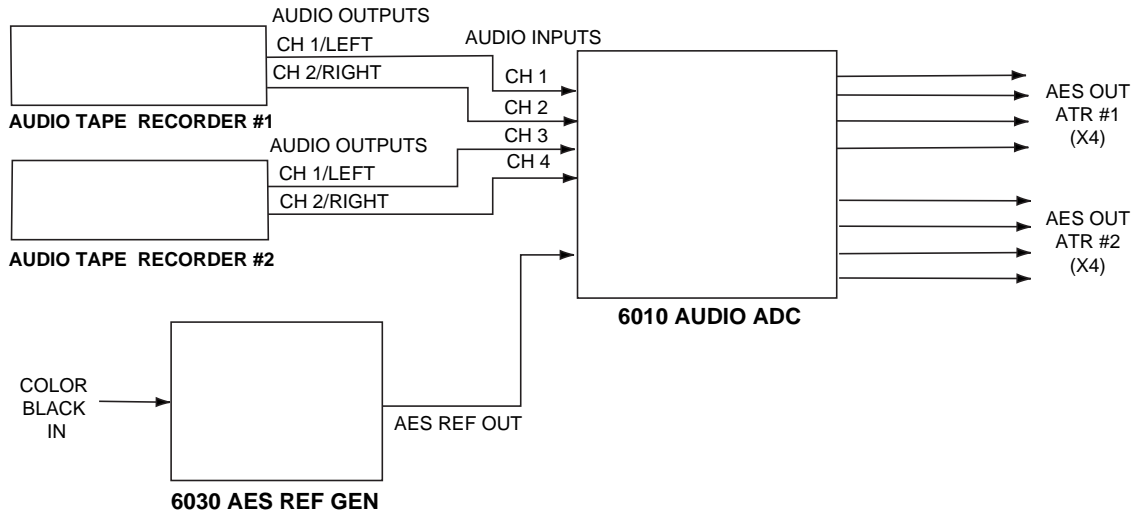

Audio Output Conversion of Two Independent 2-Track Analog Tape Recorders

Driving a 6010 Using a Single-ended (unbalanced) Source

The 6010 has balanced transformerless inputs. The diagram below shows how to drive a 6010 using a single-ended (unbalanced) source.

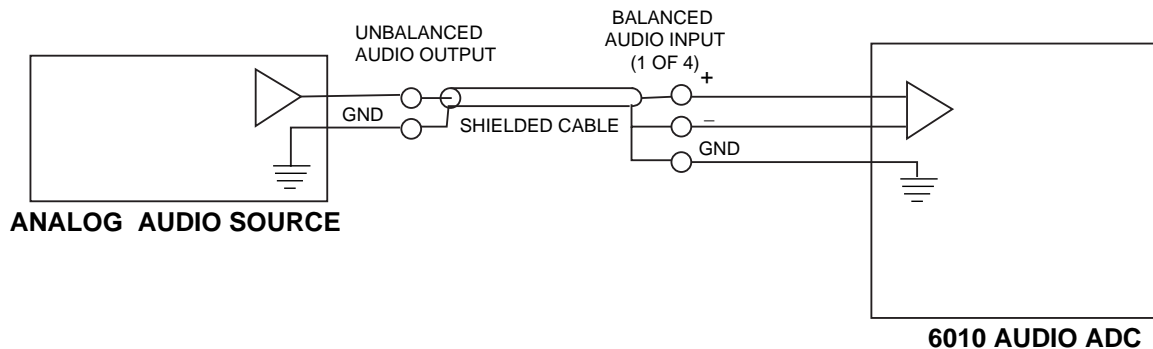

6010 Driven by Single-Ended (unbalanced) Source

INSTALLATION

Plug the 6010 module into any one of the ten slots in the frame and install the plastic overlay provided onto the corresponding group of rear BNC connectors associated with the module location. Note that the plastic overlay has an optional adhesive backing for securing it to the frame. Use of the adhesive backing is only necessary if you would like the location to be permanent and is not recommended if you need to change module locations. This module may be hot-swapped (inserted or removed) without powering down or disturbing performance of the other modules in the system.

CABLING

Refer to the backplane diagram of the module below for cabling instructions.

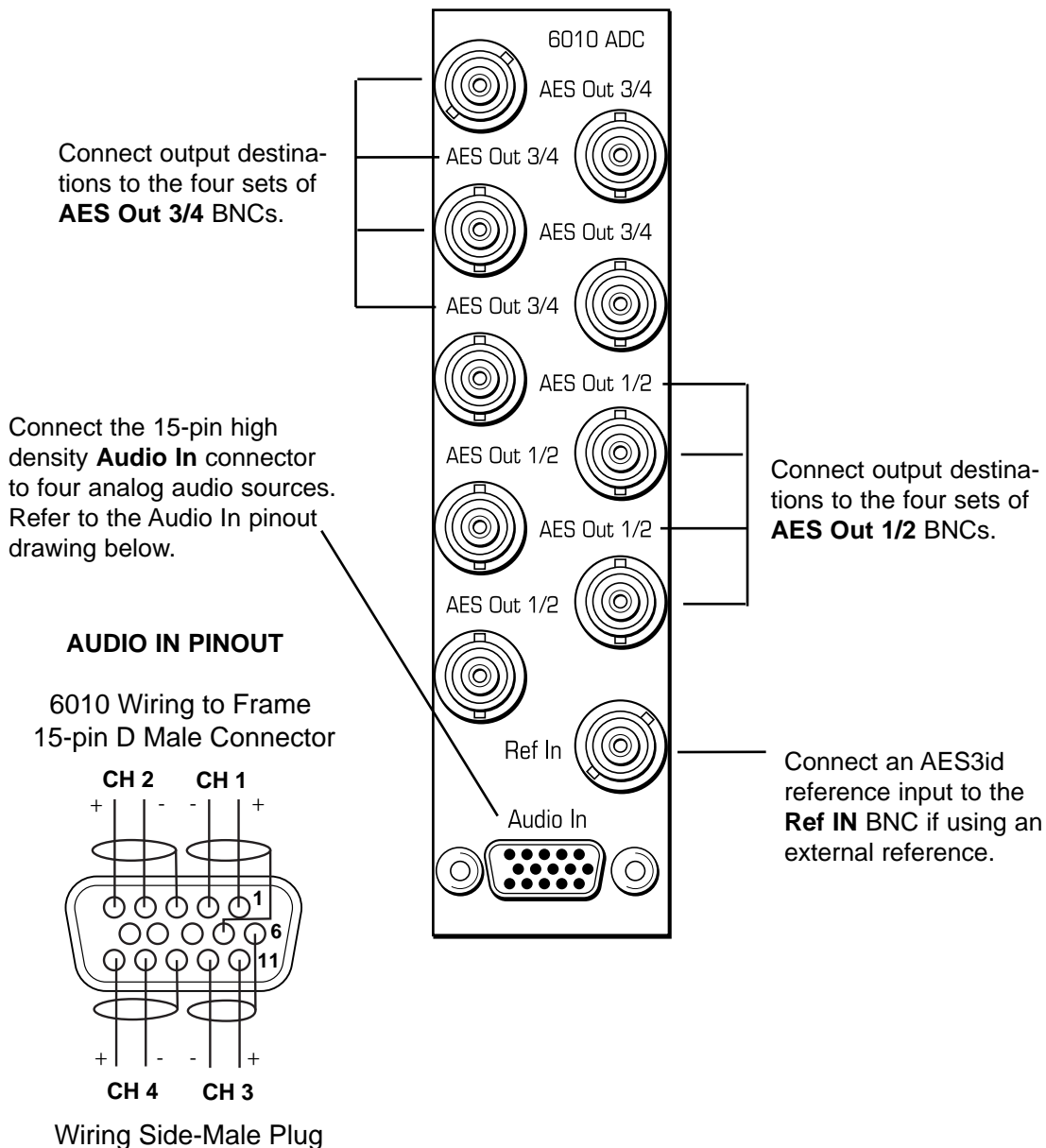

MODULE CONFIGURATION AND CONTROL

The parameters for each Avenue module must be configured after installation. This can be done remotely using one of the Avenue remote control options or locally using the module front panel controls. Each module has a **REMOTE/LOCAL** switch on the front edge of the circuit board which must first be set to the control mode you will be using.

The configuration parameter choices for the module will differ between **Remote** and **Local** modes. In **Remote** mode, the choices are made through software and allow more selections. The **6010 Parameter Table** below summarizes and compares the various configuration parameters that can be set remotely or locally and the default/factory settings.

If you are not using an remote control option, the module parameters must be configured from the front panel switches. Parameters that have no front panel control will be set to a default value. The **Local** switches are illustrated in the **Front Panel Controls and Indicators** section following the **6010 Parameter Table**.

Avenue module parameters can be configured and controlled remotely from one or both of the remote control options, the Avenue Touch Screen or the Avenue PC Application. Once the module parameters have been set remotely, the information is stored on the module CPU. This allows the module be moved to a different cell in the frame at your discretion without losing the stored information. Remote configuration will override whatever the switch settings are on the front edge of the module.

For setting the parameters remotely using the Avenue PC option, refer to the **Avenue PC Remote Configuration** section of this document.

For setting the parameters remotely using the Avenue Touch Screen option, refer to the **Avenue Touch Screen Remote Configuration** section of this data pack following Avenue PC.

6010 Parameter Table

CONTROL	LOCAL	REMOTE	DEFAULT VALUE
Ch 1/2 Mode Ch 3/4 Mode	No Adjustment	2-Channel Stereo Quad Tracking	Quad Tracking
CH 1-4 Digital Ref	AB Switch: 00 for -20 dBFS 01 for -18 dBFS 10 for -16 dBFS	-20 dBFS -18 dBFS -16dBFS (Ch 1-4 Quad Tracking, Ch 1/2 and/or 3/4 stereo pair or individual channel adjustment)	N/A
Ch 1-4 Analog Ref	Shaft Encoder: -10dBu to +8dBu	-10dBu to +8dBu (Ch 1-4 Quad Tracking, Ch 1/2 and/or 3/4 stereo pair or individual channel adjustment)	N/A

Front Panel Controls and Indicators

Each front edge indicator and switch setting is explained in the diagram below:

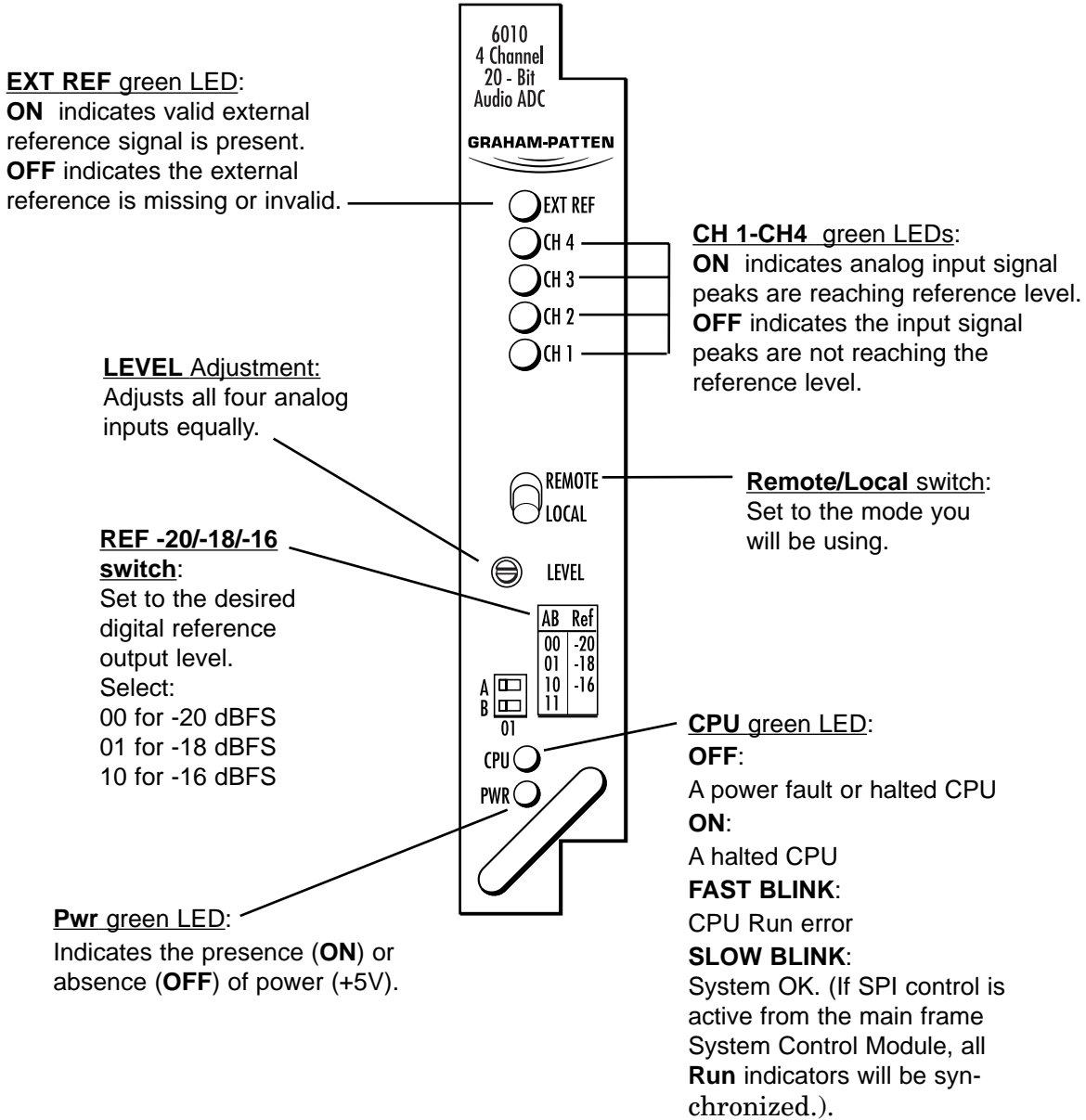

Avenue PC Remote Configuration

The Avenue PC remote control menus for this module are illustrated and explained in this section. Refer to the **6010 Parameter Table** shown earlier for a summary of available parameters that can be set remotely through the menus illustrated. For more information on using Avenue PC, refer to the Avenue PC Control Application Software data pack that came with the option.

6010 Avenue PC Menus

The menus for the **6010 Audio ADC** in the Avenue PC application allow you to set the parameters for four channels of audio on this module. You may choose from three operating modes, **2-Channel**, **Stereo** or **Quad Tracking**.

You may set all four channels to **2-Channel** mode, where each of the four audio channels will be independent of each other. Adjustments may be made to each channel individually and will not affect the other channels. Menu selections are provided for each channel as shown in the following section.

You may set the four channels to **Stereo** mode, where Channels 1 and 2 and Channels 3 and 4 are stereo pairs. Adjustments made in the menus to one channel in the pair will change the other channel. Channel 1 and 2 can be set to be independent (**2-Channel**) while Channel 3 and 4 can be set to be a stereo pair if desired (or vice versa).

All four channels can be set to **Quad Tracking** where all channels will track together. If parameters are changed in one channel, the other channels will track the change. Selecting **Quad Tracking** in any one of the menus will change all channels to quad tracking mode. A **Quad Menu** has been provided to allow easier adjusting and monitoring of all four channels together.

In the **Ch 1/2 Menu** shown below, set the following parameters:

- **Ch 1/2 Mode** - set the operating modes for Channels 1 and 2. Choose from **2-Channel** (Ch 1 and 2 will be independent), **Stereo** (Ch 1/2 will be a stereo pair) or **Quad Tracking** (Ch 1-4 will track together). Note that if you have set Ch 3/4 in the next menu to **Quad Tracking** or the **Quad On** function is enabled on the **Quad Menu**, this selection will default to **Quad Tracking**.
- **Ch 1 Digital Ref** - sets the Digital Output Reference level to match the studio reference for channel 1 (in **2-Channel** mode), Ch 1/2 if in **Stereo** mode or all four channels together if in **Quad Tracking** mode.
- **Ch 1 Analog Ref** - sets the Analog Input Reference level from -10dBu to +8dBu (in 0.5dBu steps) for channel 1 only (in **2-Channel** mode), Ch 1/2 if in **Stereo** mode or all four channels if in **Quad Tracking** mode.
- **Ch 2 Dig Ref** - When **Ch 1/2 Mode** is set to **2-Channel**, this will adjust Channel 2 Digital Output Reference level only. If **Ch 1/2 Mode** is set to **Stereo**, adjustment will affect the stereo pair, or if set to **Quad Tracking**, adjustment will affect all channels.
- **Ch 2 Analog Ref** - When **Ch 1/2 Mode** is set to **2-Channel**, this will adjust Channel 2 Analog Input Reference level only. If **Ch 1/2 Mode** is set to **Stereo**, adjustment will affect the stereo pair, or if set to **Quad Tracking**, adjustment will affect all channels.

In this menu, the following indicators are available:

- **Sampling Frequency** - will indicate what frequency the module is locking to, either **External Lock** or **48kHz** (internal).
- **Clip Domain** - will indicate where clipping will occur (in the analog or digital domain).
- **Ref Level** - illuminates green when signal is reaching the Digital Output Reference level chosen.
- **D Clip1/2** - Black indicates signal is below digital clipping; Red indicates digital signal is clipping. A grayed out box indicates that digital clipping cannot occur and analog clipping will not be indicated.

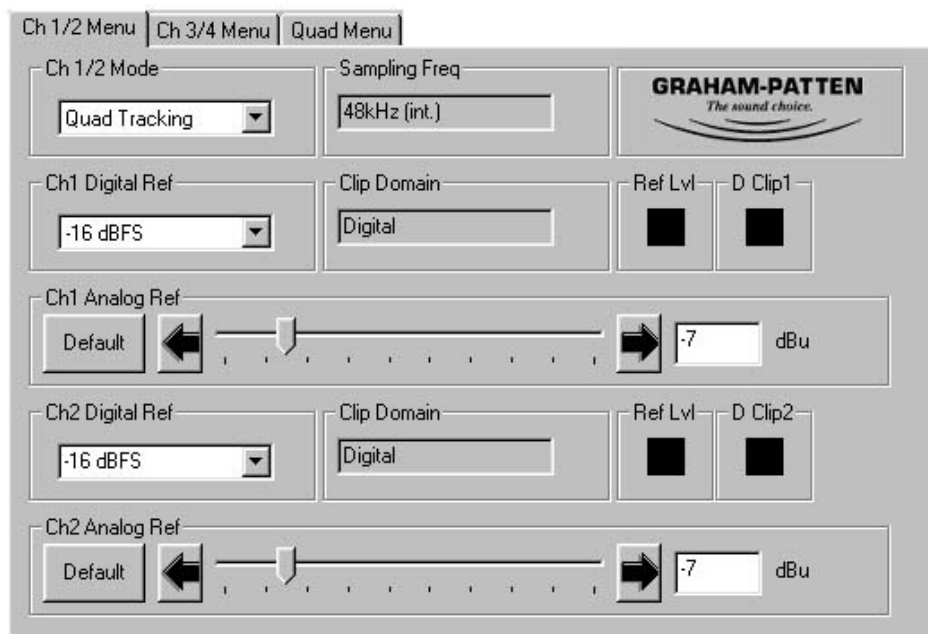

In the **Ch 3/4 Menu** shown below, set the following parameters:

- **Ch 3/4 Mode** - set the operating modes for Channels 3 and 4.
Choose from **2-Channel** (Ch 3 and 4 will be independent), **Stereo** (Ch 3/4 will be a stereo pair) or **Quad Tracking** (Ch 1-4 will track together). Note that if you have set Ch 1/2 in the previous menu to **Quad Tracking** or the **Quad On** function is enabled on the **Quad Menu**, this selection will default to **Quad Tracking**.
- **Ch 3 Digital Ref** - sets the Digital Output Reference level for channel 3 (in **2-Channel** mode). If **Ch 3/4 Mode** is set to **Stereo**, adjustment will affect the stereo pair, or if set to **Quad Tracking**, adjustment will affect all channels.
- **Ch 3 Analog Ref** - sets the Analog Input Reference level from -10dBu to +8dBu (in 0.5dBu steps) for channel 3 only (in **2-Channel** mode). If **Ch 3/4 Mode** is set to **Stereo**, adjustment will affect the stereo pair, or if set to **Quad Tracking**, adjustment will affect all channels.
- **Ch 4 Dig Ref** - When **Ch 3/4 Mode** is set to **2-Channel**, this will adjust Channel 4 Digital Output Reference level only. If **Ch 3/4 Mode** is set to **Stereo**, adjustment will affect the stereo pair, or if set to **Quad Tracking**, adjustment will affect all channels.
- **Ch 4 Analog Ref** - When **Ch 3/4 Mode** is set to **2-Channel**, this will adjust Channel 4 Analog Input Reference level only. If **Ch 3/4 Mode** is set to **Stereo**, adjustment will affect the stereo pair, or if set to **Quad Tracking**, adjustment will affect all channels.

Refer to the **Sampling Frequency**, **Clip Domain**, **Ref Level** and **D Clip** indicator explanations in the previous menu.

The screenshot displays the 'Ch 3/4 Menu' interface. At the top, there are three tabs: 'Ch 1/2 Menu', 'Ch 3/4 Menu' (selected), and 'Quad Menu'. The interface is organized into several sections:

- Ch 3/4 Mode:** A dropdown menu set to '2-Channel'.
- Sampling Freq:** A text field showing '48kHz (int.)'.
- GRAHAM-PATTEN:** The logo with the tagline 'The sound choice.'
- Ch3 Digital Ref:** A dropdown menu set to '-20 dBFS'.
- Clip Domain:** A text field showing 'Digital'.
- Ref Lvl:** A black square indicator.
- D Clip3:** A black square indicator.
- Ch3 Analog Ref:** A slider control with 'Default' on the left and '4 dBu' on the right.
- Ch4 Digital Ref:** A dropdown menu set to '-18 dBFS'.
- Clip Domain:** A text field showing 'Analog'.
- Ref Lvl:** A black square indicator.
- D Clip4:** An empty square indicator.
- Ch4 Analog Ref:** A slider control with 'Default' on the left and '8 dBu' on the right.

The **Quad Menu** shown below has been provided to allow adjusting and monitoring all four channels at the same time when in **Quad Tracking** mode. Set the parameters as follows:

- **Channel Mode** - Click in the **Quad On** box to enable quad tracking simultaneously for all four channels. Note that **Quad Tracking** can also be enabled in any of the previous **Channel** mode menus.
- **Digital Ref** - set all four channels for the digital output reference to match your studio reference.
- **Analog Ref** - adjusts the Analog input reference level of all four channels to -10dBu to +8dBu (in 0.5dBu steps).

NOTE: Digital and Analog Ref settings above will only be active when **Quad On** is checked.

The following indicators are available in the menu below:

- **Sampling Frequency** - will indicate what frequency the module is locking to, either **External Lock** or **48kHz** (internal).
- **D Clip 1-4** - Black indicates signal is below digital clipping; Red indicates digital signal is clipping. A grayed out box indicates that digital clipping cannot occur and analog clipping will not be indicated.
- **Ref Lvl** - will illuminate green when each channel is reaching the digital output reference level chosen.
- **Clip Domain** - will indicate where clipping will occur (Analog or Digital domain).

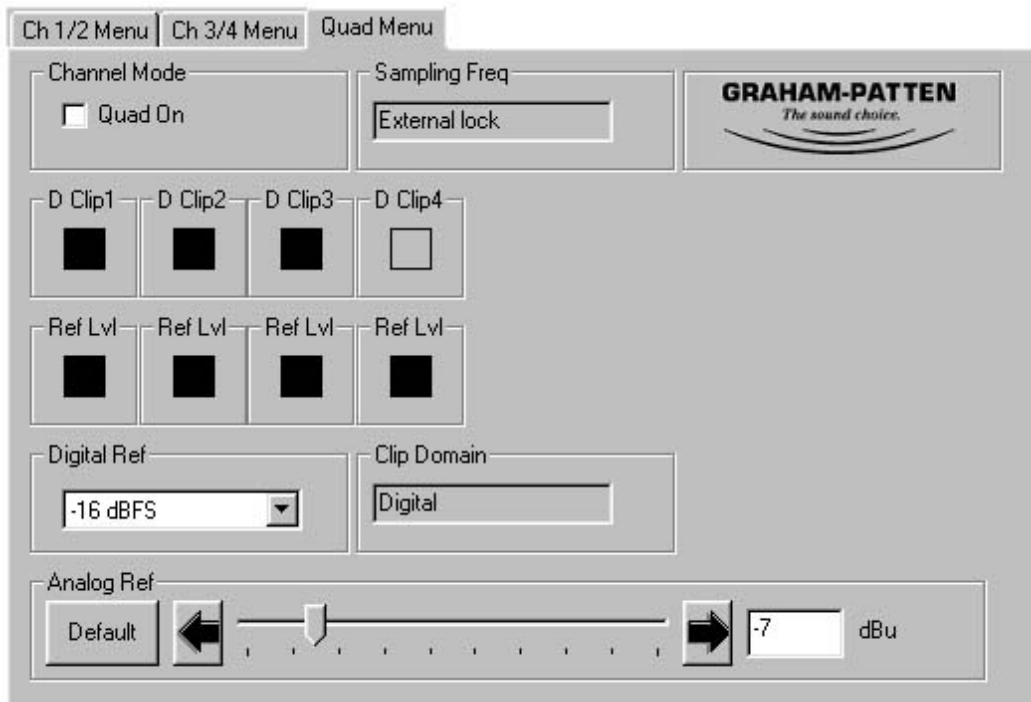

Avenue Touch Screen Remote Configuration

Avenue Touch Screen remote control menus for this module are illustrated and explained below. Refer to the **6010 Parameter Table** shown previously for a summary of available parameters that can be set remotely through the menus illustrated. For more information on using Avenue Touch Screen, refer to the Avenue Touch Screen data pack that came with the option.

6010 Avenue Touch Screen Menus

In the **Ch 1 Menu** shown below, set the following parameters:

- **Ch 1/2 Mode** - set the operating modes for Channels 1 and 2. Choose from **2-Channel** (Ch 1 and 2 will be independent), **Stereo** (Ch 1/2 will be a stereo pair) or **Quad Tracking** (Ch 1-4 will track together). Note that if you have set Ch 3/4 to **Quad Tracking** or the **Quad On** function is enabled on the **Quad Menu**, this selection will default to **Quad Tracking**.
- **Ch 1 Digital Ref** - sets the Digital Output Reference level to match the studio reference for channel 1 (in **2-Channel** mode), Ch 1/2 if in **Stereo** mode or all four channels together if in **Quad Tracking** mode.
- **Ch 1 Analog Ref** - sets the Analog Input Reference level from -10dBu to +8dBu (in 0.5dBu steps) for channel 1 only (in **2-Channel** mode), Ch 1/2 if in **Stereo** mode or all four channels if in **Quad Tracking** mode.

In all channel menus, the following indicators are available:

- **Sampling Frequency** - will indicate what frequency the module is locking to, either **External Lock** or **48kHz** (internal).
- **Clip Domain** - will indicate where clipping will occur (in the analog or digital domain).
- **Ref Level** - illuminates green when signal is reaching the Digital Output Reference level chosen.
- **D Clip1** - Black indicates signal is below digital clipping; Red indicates digital signal is clipping. A grayed out box indicates that digital clipping cannot occur and analog clipping will not be indicated.

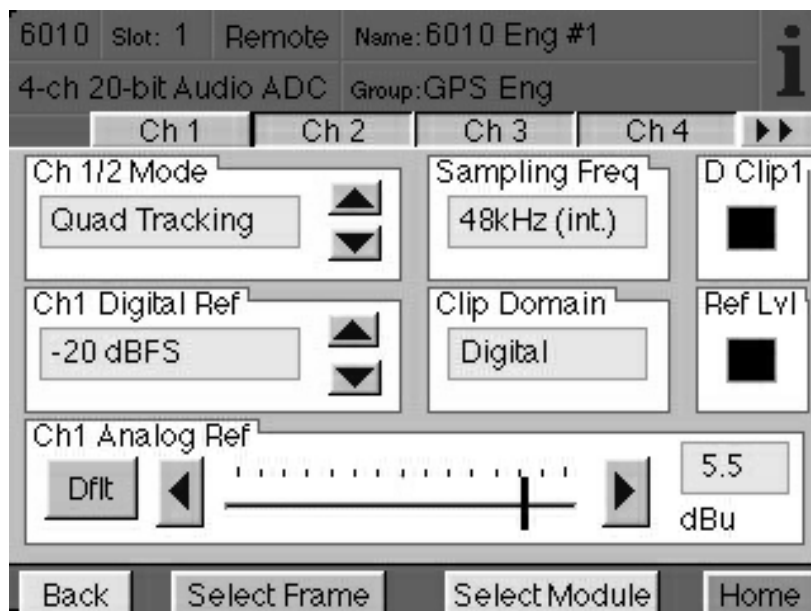

In the **Ch 2 Menu** shown below, set the following parameters:

- **Ch 1/2 Mode** - set the operating modes for Channels 1 and 2. Choose from **2-Channel** (Ch 1 and 2 will be independent), **Stereo** (Ch 1/2 will be a stereo pair) or **Quad Tracking** (Ch 1-4 will track together). Note that if you have set Ch 3/4 to **Quad Tracking** or the **Quad On** function is enabled on the **Quad Menu**, this selection will default to **Quad Tracking**.
- **Ch 2 Dig Ref** - When **Ch 1/2 Mode** is set to **2-Channel**, this will adjust Channel 2 Digital Output Reference level only. If **Ch 1/2 Mode** is set to **Stereo**, adjustment will affect the stereo pair, or if set to **Quad Tracking**, adjustment will affect all channels.
- **Ch 2 Analog Ref** - When **Ch 1/2 Mode** is set to **2-Channel**, this will adjust Channel 2 Analog Input Reference level only. If **Ch 1/2 Mode** is set to **Stereo**, adjustment will affect the stereo pair, or if set to **Quad Tracking**, adjustment will affect all channels.

In this menu, the indicator descriptions are identical to **Channel 1** on the previous page.

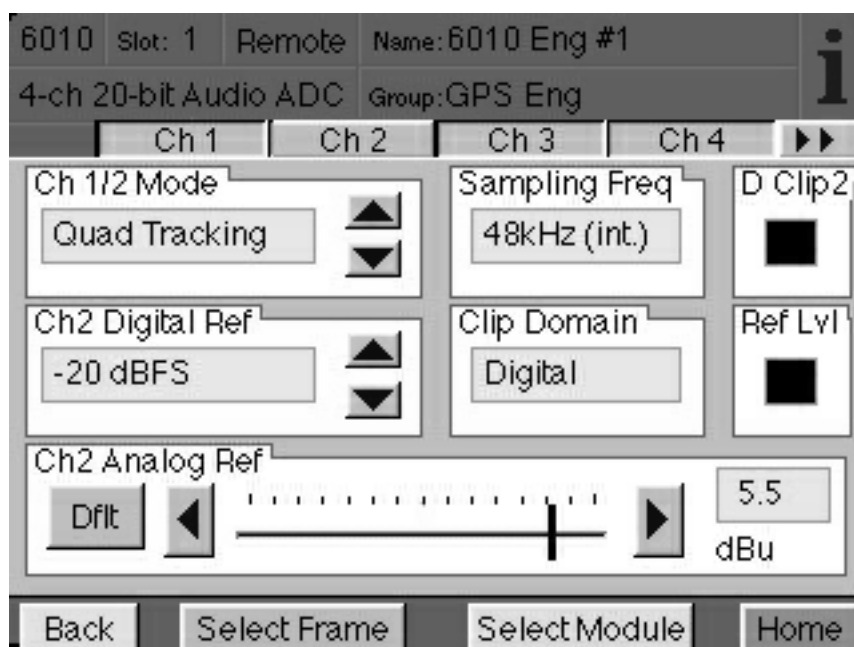

In the **Ch 3 Menu** shown below, set the following parameters:

- **Ch 3/4 Mode** - set the operating modes for Channels 3 and 4.
Choose from **2-Channel** (Ch 3 and 4 will be independent), **Stereo** (Ch 3/4 will be a stereo pair) or **Quad Tracking** (Ch 1-4 will track together). Note that if you have set Ch 1/2 to **Quad Tracking** or the **Quad On** function is enabled on the **Quad Menu**, this selection will default to **Quad Tracking**.
- **Ch 3 Digital Ref** - sets the Digital Output Reference level for Channel 3 (in **2-Channel** mode). If **Ch 3/4 Mode** is set to **Stereo**, adjustment will affect the stereo pair, or if set to **Quad Tracking**, adjustment will affect all channels.
- **Ch 3 Analog Ref** - sets the Analog Input Reference level from -10dBu to +8dBu (in 0.5dBu steps) for channel 3 only (in **2-Channel** mode). If **Ch 3/4 Mode** is set to **Stereo**, adjustment will affect the stereo pair, or if set to **Quad Tracking**, adjustment will affect all channels.

Refer to the **Sampling Frequency**, **Clip Domain**, **Ref Level** and **D Clip** indicator descriptions in the **Channel 1** menu.

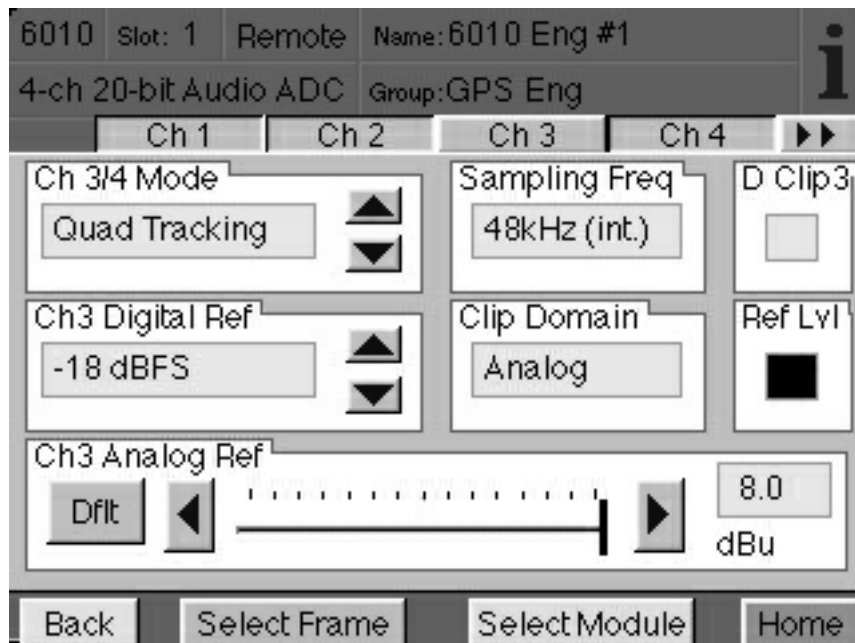

In the **Ch 4 Menu** shown below, set the following parameters:

- **Ch 3/4 Mode** - set the operating modes for Channels 3 and 4.
Choose from **2-Channel** (Ch 3 and 4 will be independent), **Stereo** (Ch 3/4 will be a stereo pair) or **Quad Tracking** (Ch 1-4 will track together). Note that if you have set Ch 1/2 to **Quad Tracking** or the **Quad On** function is enabled on the **Quad Menu**, this selection will default to **Quad Tracking**.
- **Ch 4 Dig Ref** - When **Ch 3/4 Mode** is set to **2-Channel**, this will adjust Channel 4 Digital Output Reference level only. If **Ch 3/4 Mode** is set to **Stereo**, adjustment will affect the stereo pair, or if set to **Quad Tracking**, adjustment will affect all channels.
- **Ch 4 Analog Ref** - When **Ch 3/4 Mode** is set to **2-Channel**, this will adjust Channel 4 Analog Input Reference level only. If **Ch 3/4 Mode** is set to **Stereo**, adjustment will affect the stereo pair, or if set to **Quad Tracking**, adjustment will affect all channels.

Refer to the **Sampling Frequency**, **Clip Domain**, **Ref Level** and **D Clip** indicator descriptions in the **Channel 1** menu.

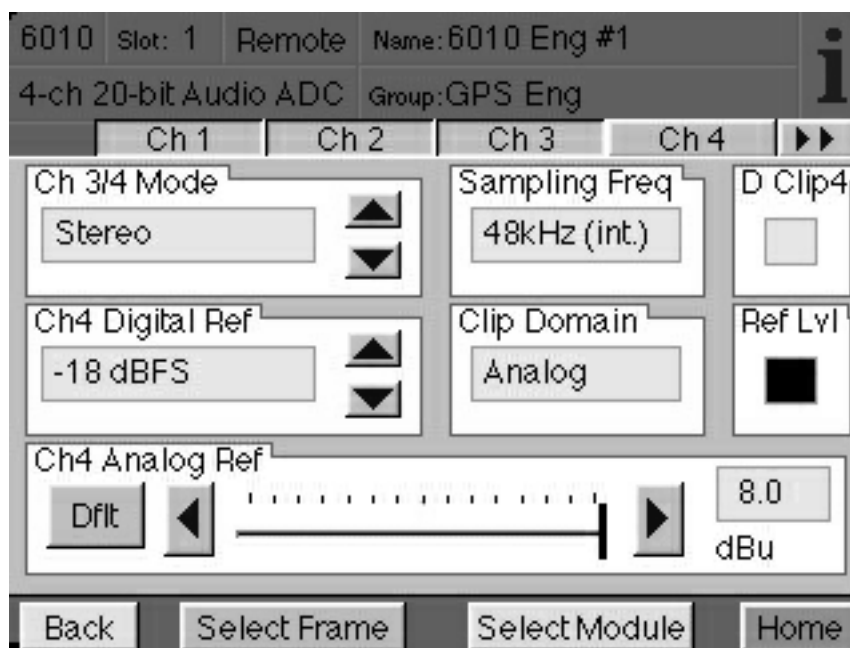

Model 6010 Four Channel 20-bit Audio ADC

The **Quad Menu** shown below has been provided to allow adjusting and monitoring all four channels at the same time when in **Quad Tracking** mode. Set the parameters as follows:

- **Channel Mode** - Click in the **Quad On** box to enable quad tracking simultaneously for all four channels. Note that **Quad Tracking** can also be enabled in any of the previous **Channel** mode menus.
 - **Digital Ref** - set all four channels for the digital output reference to match your studio reference.
 - **Analog Ref** - adjusts the Analog input reference level of all four channels to -10dBu to +8dBu (in 0.5dBu steps).
- NOTE:** Digital and Analog Ref settings above will only be active when **Quad On** is checked.

The following indicators are available in the menu below:

- **Sampling Frequency** - will indicate what frequency the module is locking to, either **External Lock** or **48kHz** (internal).
- **D Clip 1-4** - Black indicates signal is below digital clipping; Red indicates digital signal is clipping. A grayed out box indicates that digital clipping cannot occur and analog clipping will not be indicated.
- **Ref Lvl** - will illuminate green when each channel is reaching the digital output reference level chosen.
- **Clip Domain** - will indicate where clipping will occur (Analog or Digital domain).

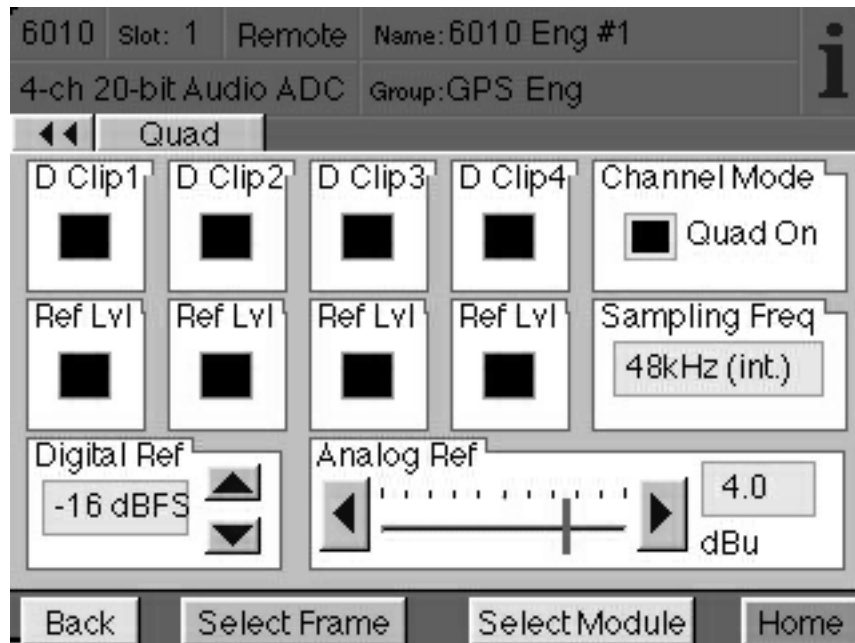

TROUBLESHOOTING

To aid in troubleshooting, signal reference levels and presence, power and CPU status can be easily monitored from the front panel of this module using the indicators explained in the previous section.

If using the **Remote** mode, the following status items can be monitored using the Avenue Touch Screen Control Panel or PC Application:

- External reference present and valid
- Channels 1-4 analog inputs reaching reference levels
- Power status
- Slot ID, Software Version and Board Revision

Refer to the overall troubleshooting tips given below for the **6010** module:

No status lights are lit on front panel:

- Check that frame power is present (green LED{s} on frame power supplies).
- Check that module is firmly seated in frame. Try removing it and plugging it in again.

Can't control module:

- Check status of CPU **Run** red LED. Should be blinking slowly and in unison with other modules if System Control module is present. If not, try removing it and plugging it in again.
- System Control module may not be working properly if installed.

No AES signal out of module:

- Check cabling to input of module.

No Ext Ref indication:

- Check for presence and validity of external reference input signal if required. (6010 will default to 48kHz internally.)

You may also refer to the technical support section of the Ensemble or Graham-Patten web sites for the latest information on your equipment at the URLs below:

<http://www.ensembledesigns.com/support>

<http://www.gpsys.com>

SOFTWARE UPDATING

Software upgrades for each module can be downloaded remotely if the optional System Control module is installed. These can be downloaded onto your PC and then Avenue PC will distribute the update to the individual module. (Refer to the Avenue PC documentation for more information) Periodically, updates will be posted on our web site. If you do not have the required System Control Module and Avenue PC, modules can be sent back to the factory for software upgrades.

WARRANTY AND FACTORY SERVICE

Warranty

This Module is covered by a five year limited warranty, as stated in the main Preface of this manual. If you require service (under warranty or not), please contact Ensemble Designs or Graham-Patten Systems and ask for customer service before you return the unit. This will allow the service technician to provide any other suggestions for identifying the problem and recommend possible solutions.

Factory Service

If you return equipment for repair, please get a Return Material Authorization Number (RMA) from the factory first.

Ship the product and a written description of the problem to:

Ensemble Designs, Inc.

Attention: Customer Service RMA #####

870 Gold Flat Rd.

Nevada City, CA. 95959 USA

(530) 478-1830

Fax: (530) 478-1832

service@endes.com

<http://www.ensembledesigns.com>

Be sure to put your RMA number on the outside of the box.

OR

Graham-Patten Systems, Inc.

13366 Grass Valley Avenue

Grass Valley, CA 95945

(800) 422-6662 or (530) 273-8412

Fax: (530) 273-7458

service@gpsys.com

<http://www.gpsys.com>

SPECIFICATIONS

6010 Four Channel 20-bit Audio ADC

Analog Input Z:	>15k ohms, balanced, transformerless
CMRR:	>60dB, 20Hz - 10kHz
Analog Input Reference Level:	-10dBu to +8dBu
Digital Output Reference Level:	-16, -18, -20dBFS
AES3id reference input:	1 volt p-p, terminated in 75 ohms
AES outputs:	1 volt p-p, 75 ohm source terminated
Sample Rate:	48kHz or External 30-50kHz
Frequency Response:	+0/-0.1dB, 20Hz - 20kHz
Crosstalk:	<-84dB, 20Hz - 20kHz
Dynamic range:	95dB

Due to ongoing product development, all specifications subject to change.