

50|TS

microplate washer



Operator's Manual

50™ TS Washer Operator's Manual

**June 2019
Part Number 1551000
Revision D
BioTek Instruments, Inc.**

Notices

BioTek[®] Instruments, Inc.
Highland Park, P.O. Box 998
Winooski, Vermont 05404-0998 USA

All Rights Reserved

© 2019, BioTek[®] Instruments, Incorporated. No part of this publication may be reproduced, transcribed, or transmitted in any form, or by any means electronic or mechanical, including photocopying and recording, for any purpose other than the purchaser's use without written permission of BioTek Instruments, Inc.

Trademarks

BioTek[®] is a registered trademark and 50[™] TS Washer is a trademark of BioTek Instruments, Inc.

Microsoft[®], Internet Explorer[®], Windows[®], Windows 7, Windows 10, and Excel[®] are either registered trademarks or trademarks of Microsoft Corporation in the United States and/or other countries.

All other trademarks are the property of their respective holders.

Restrictions and Liabilities

Information in this document is subject to change and does not represent a commitment by BioTek Instruments, Inc. Changes made to the information in this document will be incorporated in new editions of the publication. No responsibility is assumed by BioTek for the use or reliability of software or equipment that is not supplied by BioTek or its affiliated dealers.

Contents

Notices	ii
All Rights Reserved	ii
Trademarks	ii
Restrictions and Liabilities	ii
Contents	iii
Contact Information	vii
Global Service and Support	vii
Customer Service and Sales	vii
Service/TAC	vii
European Coordination Center/Authorized European Representative	vii
Revision History	viii
Document Conventions	viii
Intended Use Statement	ix
Quality Control	ix
Warranty and Product Registration	ix
Repackaging and Shipping	ix
Warnings	ix
Hazards and Precautions	x
Hazards	x
Precautions	xi
CE Mark	xiii
Directive 2014/30/EU: Electromagnetic Compatibility	xiii
Directive 2014/35/EU Low Voltage (Safety)	xiv
Directive 2012/19/EU: Waste Electrical and Electronic Equipment	xiv
Directive 98/79/EC: In Vitro Diagnostics (if labeled for this use)	xiv
Electromagnetic Interference and Susceptibility	xiv
USA FCC CLASS A	xiv
Canadian Department of Communications Class A	xv
User Safety	xv
Safety Symbols	xvi
Introduction	1
Introducing the 50™ TS Washer	2
Product Support & Service	3
Contacting the Technical Assistance Center	3
Returning Instruments for Service/Repair	3
Hardware Features	4
Package Contents	5
Optional Accessories	6
Physical Specifications	7
Performance Specifications	9
50 TS Washer Variations	12
Manifold Variations	12

Plate Carrier Variations	14
Installation	17
Unpack and Inspect the Instrument	18
Setting Up the 50 TS	19
Operating Environment	19
Connect the Fluid Supply and Waste System	19
Install the Liquid Level Alert System (Optional)	24
Install Vacuum Pump Muffler (Optional)	25
Install the 8, 8s, 12, 2x8, or 4 Well Manifold	26
Install the 8,16 Well Manifold	27
Install the Microplate Carrier	27
Installation Final Check	29
Attach the Mist Shield	30
Connecting the Power Supply and Cord	31
Verify Performance	32
Repacking and Shipping	33
Operation	37
Prime Options	38
Quick Prime	39
AutoPrime	40
Wash a Plate	41
Optimize Performance	44
Run a Predefined Protocol	45
Running a Protocol	45
Predefined Onboard Protocols Listing	46
Create a Protocol	50
Protocol Parameters Reference Tables	51
Wash Protocol Parameters	52
Dispense Protocol Parameters	53
Dispense and Prime Flow Rates	55
Aspiration Protocol Parameters	55
Soak and Shake Protocol Parameters	57
Special Applications	58
Biomagnetic Separation Assays	58
Vacuum Filtration for Filter Plate Assays	60
Vacuum Filtration Carrier- Load or Unload a Plate	63
System Startup	64
How to copy a protocol	64
How to delete a protocol	65
Instrument Configuration - Setup Controls	66
Instrument Settings	66
AutoPrime	67
Maintenance	69
About Maintaining the Washer	70
Warnings & Precautions	71
Recommended Maintenance Schedule	72
Prime Programs	73

Daily Maintenance: Rinse/Soak the Fluid Path	77
Maintenance Programs	77
DAY_RINSE	77
AutoPrime	78
Enable AutoPrime	78
Overnight/Multi-Day Maintenance	78
Removing Protein Residuals and Fungi Growth	79
Clean Components	80
Clean the Bottles	81
Clean the Touchscreen	81
Clean the Exterior Surfaces	81
Clean the Carrier	82
Clean the Mist Shield	83
Clean the Manifold	83
Tools for cleaning dispense and aspirate tubes	83
Clean the Aspirate and Dispense Tubes	84
Decontaminate the Washer	87
Decontamination Tools and Supplies	88
Decontaminate the External Surfaces and Components	89
Decontamination Procedure for Tubing and Manifold	90
Decontaminate the Vacuum Filtration Carrier	90
Alternate Decontamination Procedure for Tubing and Manifold	91
Prepare for Storage or Shipment	91
Storing the Washer	92
Replace Components	93
Replacement (Spare) Parts Listing	93
Replace (or Clean) the Check Valves	94
Vacuum Filtration Carrier: Replace the Gasket	94
Maintenance/Performance Log	96
Qualification	99
About Instrument Qualification	100
IQ/OQ/PQ	101
Qualification Schedule	102
Recommended Performance Qualification Schedule	102
Which Tests to Perform?	103
Liquid Tests	104
Evacuation Efficiency Test	104
Dispense Precision Test	104
Materials	105
Test solutions	106
Liquid Test Protocols: Default Parameters	107
Self-Test	109
Dispense Precision Test (8, 8s, 2X8, and 12 Well)	110
Annual Buffer Switching Dispense Precision Test	112
Evacuation Efficiency Test (8, 8s, 2X8, and 12 Well)	113
Vacuum Filtration Evacuation Efficiency Test	114
Dispense Precision Test (8,16 Well)	115

Annual Buffer Switching Dispense Precision Test	117
Evacuation Efficiency Test (8,16 Well)	118
Dispense Precision Test (4 Well Manifold)	119
Evacuation Efficiency Test (4 Well Manifold)	120
Create Qualification Protocols for 4 Well Manifold	121
Troubleshooting	133
Troubleshooting Overview	134
Troubleshooting Checklist	134
Error Codes	134
Fatal Errors	135
General Errors	136
Troubleshooting Charts	146
Washer Start-Up	146
Fluid Aspiration	146
Fluid Delivery	150
Dispense Volume Invalid for Manifold Type (0F00 Error)	153
Fluid Leakage	154
Carrier Movement	156
Washer Manifold Movement	157
Syringe Drive Movement	157
Microplate Scratches	157
	159

Contact Information

BioTek® Instruments, Inc.

Highland Park, P.O. Box 998

Winooski, Vermont 05404-0998 USA

Global Service and Support

BioTek instrument service and repair is available worldwide at one of BioTek's International Service Centers and in the field at your location. To arrange for service or repair, contact the office nearest you; visit www.biotek.com for up-to-date contact information. For customer service, sales, and technical assistance, refer to the information below.

Customer Service and Sales

Phone: 888-451-5171 (toll free in the U.S.)
802-655-4740 (outside the U.S.)
Fax: 802-655-7941
E-Mail: customercare@biotek.com

Service/TAC

Phone: 800-242-4685 (toll free in the U.S.)
802-655-4740 (outside the U.S.)
Fax: 802-654-0638
E-Mail: tac@biotek.com

European Coordination Center / Authorized European Representative

BioTek® Instruments GmbH
Kocherwaldstrasse 34
D-74177 Bad Friedrichshall
Germany

Internet: www.biotek.de
Phone: +49 (0) 7136 9680
Fax: +49 (0) 7136 968 111
E-Mail: info@biotek.de

Revision History

Revision	Date	Changes
A	4/2017	First Issue
B	8/2017	Updates to Introduction chapter.
C	10/2017	Under 'Precautions' and 'Operating Environment' clarified text describing the operating environment temperature range. Adjusted text box size in some photos to reveal text that had been inadvertently cropped. Fix incorrect header information in chapters 5 and 6.
D	6/2019	Fixed heading levels in Preface, changed "Service Call Notice" number to "work order number," added the Carrier-Manifold matrix to the Specifications.

Document Conventions

This manual uses the following typographic conventions:

- This note format calls attention to important information.



Warnings are presented in this style to call attention to potential hazards and other safety concerns.



This icon calls attention to safety information.

Important: Some important information is formatted this way.



Tips and suggestions for improving performance are formatted this way.

■ **Water:** Daily maintenance is the key to keeping the washer performing to specifications. In the maintenance procedures provided in this manual, the requirement to use deionized (DI) or distilled (dH₂O) water can be met by numerous water purification methods, including MilliQ™. A minimum water purity of 2mOhm is expected.

Intended Use Statement

- The 50™ TS Washer provides microplate priming, dispensing, and washing for ELISA™, fluorescence and chemiluminescence immunoassays, cellular and agglutination assays.
- If the instrument has an “IVD” label it may be used for clinical and non-clinical purposes, including research and development. If there is no such label the instrument may only be used for research and development or other non-clinical purposes

Quality Control

It is considered good laboratory practice to run laboratory samples according to instructions and specific recommendations included in the assay package insert for the test to be conducted. Failure to conduct Quality Control checks could result in erroneous test data.

Warranty and Product Registration

Please take a moment to review the Warranty information that shipped with your product. Please also register your product with BioTek to ensure that you receive important information and updates about the product(s) you have purchased.

You can register online through BioTek’s Customer Resource Center (CRC) at www.biotek.com or by calling 888/451-5171 or 802/655-4740.

Repackaging and Shipping

If you need to ship the instrument to BioTek for service or repair, contact BioTek for a work order number, and be sure to use the original packing materials. Other forms of commercially available packaging are not recommended and can void the warranty. If the original packing materials have been damaged or lost, contact BioTek for replacement packing.

Warnings



Operate the instrument on a level, stable surface away from excessive humidity.

When operated in a safe environment, according to the instructions in this manual, there are no known hazards associated with the 50™ TS Washer. However, the operator should be aware of certain situations that could result in serious injury. See [Hazards and Precautions](#) on the next page.

Strict adherence to instrument maintenance and qualification procedures is required to ensure accurate dispense volumes and risk-free operation.

Hazards and Precautions

Hazards

The following hazard warnings are provided to help avoid injury:



Warning! Power Rating. The instrument's power supply or power cord must be connected to a power receptacle that provides voltage and current within the specified rating for the system. Use of an incompatible power receptacle may produce electrical shock and fire hazards.

Warning! Electrical Grounding. Never use a plug adapter to connect primary power to the external power supply. Use of an adapter disconnects the utility ground, creating a severe shock hazard. Always connect the power cord directly to an appropriate receptacle with a functional ground.

Warning! Service. Only qualified technical personnel should perform service procedures on internal components.

Warning! Accessories. Only accessories which meet the manufacturer's specifications shall be used with the instrument.

Warning! Lubricants. Do not apply lubricants to the microplate carrier or carrier track. Lubricant on the carrier mechanism will attract dust and other particles, which may obstruct the carrier path and cause the instrument to produce an error.

Warning! Liquids. Avoid spilling liquids on the instrument; fluid seepage into internal components creates a potential for shock hazard or instrument damage. If a spill occurs while a program is running, abort the program and turn the instrument off. Wipe up all spills immediately. Do not operate the instrument if internal components have been exposed to fluid.

Warning! Unspecified Use. Failure to operate this equipment according to the guidelines and safeguards specified in this manual could result in a hazardous condition.

Warning! Direct Drain Waste. If installed, the direct drain waste system pumps waste fluids from the washer directly into a sink or tank, and, potentially into public waste water systems. Because the waste may be a biohazard, you must ensure that you are in compliance with your local or

national government's laws regarding safe disposal of the waste.

Warning! Software Quality Control. The operator must follow the manufacturer's assay package insert when modifying software parameters and establishing washing or dispensing methods. **Failure to conduct quality control checks could result in erroneous test data.**



Warning! Internal Voltage. Always turn off the power switch and unplug the power supply before cleaning the outer surface of the instrument.



Warning! Potential Biohazards. Some assays or specimens may pose a biohazard. Adequate safety precautions should be taken as outlined in the assay's package insert. This hazard is noted by the symbol shown here. Always wear safety glasses and appropriate protective equipment, such as chemically resistant rubber gloves and apron.



Warning! Pinch Hazard. Do not reach under the instrument during operation; the syringe pump may pinch your fingers.

Precautions

The following precautions are provided to help avoid damage to the instrument:



Caution: Service. The instrument should be serviced by BioTek authorized service personnel. Only qualified technical personnel should perform troubleshooting and service procedures on internal components.

Caution: Spare Parts. Only approved spare parts should be used for maintenance. The use of unapproved spare parts and accessories may result in a loss of warranty and potentially impair instrument performance or cause damage to the instrument.

Caution: Environmental Conditions. Do not expose the instrument to temperature extremes. For proper operation, temperatures near the instrument should remain within the range listed in the **Specifications** section. Performance may be adversely affected if temperatures fluctuate above or below this range.

Caution: Sodium Hypochlorite. Do not expose any part of the instrument to the recommended diluted sodium hypochlorite solution (bleach) for more than 20 minutes. Prolonged contact may damage the instrument surfaces. Be certain to rinse and thoroughly wipe all surfaces.

Caution: Buffer Solution. Although many precautions have been taken to ensure that the instrument is as corrosion-proof as possible, the instrument is not sealed and liquids can seep into sensitive components. Make sure that any spilled buffer solution is wiped off the instrument. Prolonged exposure to salt solution may corrode parts of the microplate carrier, movement rail, springs, and other hardware.

Caution: Chemical Compatibility. Some chemicals may cause irreparable damage to the instrument. The following chemicals have been deemed safe for use in the instrument: buffer solutions (such as PBS), saline, surfactants, deionized water, 70% ethyl, isopropyl, or methyl alcohol, 40% formaldehyde, and 20% sodium hydroxide. Never use acetic acid, DMSO, or other organic solvents. These chemicals may cause severe damage to the instrument. Contact BioTek for more information and prior to using other questionable chemicals.

Caution: Bovine Serum Albumin. Solutions containing proteins, such as bovine serum albumin (BSA), will compromise the instrument's performance over time unless a strict maintenance protocol is adhered to. See **Maintenance** procedures regarding BSA.

Caution: Power Supply. Only use the power supply shipped with the instrument. Operate this power supply within the range of line voltages listed on it.

Caution: Disposal. Dispose of the instrument according to Directive 2012/19/EU, "on waste electrical and electronic equipment (WEEE)" or local ordinances.

Caution: Warranty. Failure to follow preventive maintenance protocols may **void the warranty**.

Caution: Shipping Hardware. All shipping hardware (e.g., shipping bracket etc.) must be removed before operating the instrument and reinstalled before repackaging the instrument for shipment.

Caution: Electromagnetic Environment. Per IEC 61326-2-6 it is the user's responsibility to ensure that a compatible electromagnetic environment for this instrument is provided and maintained in order that the device will perform as intended.

Caution: Electromagnetic Compatibility. Do not use this device in close

proximity to sources of strong electromagnetic radiation (e.g., unshielded intentional RF sources), because these may interfere with the proper operation.

Caution: Use BioTek-Provided Bottles Only. Do not substitute the fluid supply and waste bottles provided by BioTek with other commercially-available bottles. BioTek provides bottles that perform well with our liquid handling systems, including the vacuum pressure of the waste system.

Caution: Touchscreen. Do not use sharp implements to operate the touchscreen. Using a sharp stylus or any implement harder than a finger may damage the display.

CE Mark



Based on the testing described below and information contained herein, this instrument bears the CE mark.

■ **Note:** See the Declaration of Conformity for specific information.

Directive 2014/30/EU: Electromagnetic Compatibility

Emissions—Class A

The system has been type-tested by an independent, accredited testing laboratory and found to meet the requirements of EN 61326-1: Class A for Radiated Emissions and Line Conducted Emissions.

Verification of compliance was conducted to the limits and methods of EN 55011 (CISPR 11) Class A. In a domestic environment it may cause radio interference, in which case, you may need to mitigate the interference.

Immunity

The system has been type-tested by an independent, accredited testing laboratory and found to meet the requirements of EN 61326-1 and EN 61326-2-6 for Immunity. Verification of compliance was conducted to the limits and methods of the following:

EN 61000-4-2, Electrostatic Discharge

EN 61000-4-3, Radiated EM Fields

EN 61000-4-4, Electrical Fast Transient/Burst

EN 61000-4-5, Surge Immunity

EN 61000-4-6, Conducted Disturbances from RFI

EN 61000-4-11, Voltage Dips, Short Interruptions and Variations

Directive 2014/35/EU Low Voltage (Safety)

The system has been type-tested by an independent testing laboratory and was found to meet the requirements of this Directive. Verification of compliance was conducted to the limits and methods of the following:

EN 61010-1, "Safety requirement for electrical equipment for measurement, control and laboratory use. Part 1, General requirements."

EN 61010-2-081, "Particular requirements for automatic and semi-automatic laboratory equipment for analysis and other purposes."

Directive 2012/19/EU: Waste Electrical and Electronic Equipment

Disposal Notice: Dispose of the instrument according to Directive 2012/19/EU, "on waste electrical and electronic equipment (WEEE)" or local ordinances.

Directive 98/79/EC: In Vitro Diagnostics (if labeled for this use)

- Product registration with competent authorities.
- Traceability to the U.S. National Institute of Standards and Technology (NIST).
- EN 61010-2-101 Particular requirements for in vitro diagnostic (IVD) medical equipment.

Electromagnetic Interference and Susceptibility

USA FCC CLASS A

RADIO AND TELEVISION INTERFERENCE

NOTE: This equipment has been tested and found to comply with the limits for a Class A digital device, pursuant to Part 15 of the FCC Rules. These limits are designed to provide reasonable protection against harmful interference when the equipment is operated in a commercial environment. This equipment generates, uses, and can radiate radio frequency energy and, if not installed and used in accordance with the instruction manual, may cause harmful

interference to radio communications. Operation of this equipment in a residential area is likely to cause harmful interference, in which case the user will be required to correct the interference at their own expense.

In order to maintain compliance with FCC regulations shielded cables must be used with this equipment. Operation with non-approved equipment or unshielded cables is likely to result in interference to radio and television reception.

Canadian Department of Communications Class A

This digital apparatus does not exceed Class A limits for radio emissions from digital apparatus set out in the Radio Interference Regulations of the Canadian Department of Communications.

Le présent appareil numérique n'émet pas de bruits radioélectriques dépassant les limites applicables aux appareils numériques de la Class A prescrites dans le Règlement sur le brouillage radioélectrique édicté par le ministère des Communications du Canada.













User Safety





This device has been type-tested by an independent laboratory and found to meet the requirements of the following:

- **Underwriters Laboratories UL 61010-1**, "Safety requirements for electrical equipment for measurement, control and laboratory use; Part 1: general requirements."
- **Canadian Standards Association CAN/CSA C22.2 No. 61010-1**, "Safety requirements for electrical equipment for measurement, control and laboratory use; Part 1: general requirements."
- EN 61010 Standards, see [CE Mark on page xiii](#).

Safety Symbols

Some of the following symbols may appear on the instrument or accessories:

	<p>Alternating current Courant alternatif Wechselstrom Corriente alterna Corrente alternata</p>	 	<p>Warning, risk of crushing or pinching Attention, risque d'écrasement et pincement Warnen, Gefahr des Zerquetschens und Klemmen Precaución, riesgo del machacamiento y sejeción Attenzione, rischio di schiacciare ed intrappolarsi</p>
	<p>Direct current Courant continu Gleichstrom Corriente continua Corrente continua</p>		<p>Warning, hot surface Attention, surface chaude Vorsicht, heiße Oberfläche Precaución, superficie caliente Attenzione, superfice calda</p>
	<p>Both direct and alternating current Courant continu et courant alternatif Gleich - und Wechselstrom Corriente continua y corriente alterna Corrente continua e corrente alternata</p>	 	<p>Laser radiation: Do not stare into beam Rayonnement laser: Ne pas regarder dans le faisceau Laserstrahlung: nicht in den strahl blicken Radiación de laser: No mire fijamente al rayo Radiazione di laser: Non stare nel fascio</p>
	<p>Earth ground terminal Borne de terre Erde (Betriebserde) Borne de tierra Terra (di funzionamento)</p>		<p>Warning, potential biohazards Attention, risques biologiques potentiels Warnung! Moegliche biologische Giftstoffe Atención, riesgos biológicos Attenzioni, rischio biologico</p>
	<p>Protective conductor terminal Borne de terre de protection Schutzleiteranschluss Borne de tierra de protección Terra di protezione</p>		<p>Caution (refer to accompanying documents) Attention (voir documents d'accompagnement) Achtung siehe Begleitpapiere Atención (vease los documentos incluidos) Attenzione, consultare la doc annessa</p>

	<p>On (Supply) Marche (alimentation) Ein (Verbindung mit dem Netz) Conectado Chiuso</p>		<p>Consult instructions for use Consulter la notice d'emploi Gebrauchsanweisung beachten Consultar las instrucciones de uso Consultare le istruzioni per uso</p>
○	<p>Off (Supply) Arrêt (alimentation) Aus (Trennung vom Netz) Desconectado Aperto (sconnessione dalla rete di alimentazione)</p>		<p>In vitro diagnostic medical device Dispositif médical de diagnostic in vitro Medizinisches In-Vitro Diagnostikum Dispositivo médico de diagnóstico in vitro Dispositivo medico diagnostico in vitro</p>
	<p>Warning, risk of electric shock Attention, risque de choc électrique Gefährliche elektrische schlag Precaución, riesgo de sacudida eléctrica Attenzione, rischio di scossa elettrica</p>		<p>Separate collection for electrical and electronic equipment Les équipements électriques et électroniques font l'objet d'une collecte sélective Getrennte Sammlung von Elektro- und Elektronikgeräten Recogida selectiva de aparatos eléctricos y electrónicos Raccolta separata delle apparecchiature elettriche ed elettroniche</p>

Introduction

Thank you for purchasing the 50™ TS Washer. This chapter describes the washer's features and specifications and includes important contact information.

Introducing the 50™ TS Washer	2
Product Support & Service	3
Hardware Features	4
Package Contents	5
Optional Accessories	6
Physical Specifications	7
Performance Specifications	9
50 TS Washer Variations	12

Introducing the 50™ TS Washer

Fast, versatile, and easy to use, the 50 TS is a fully automated microplate strip washer. Its key features include:

- The precision syringe pump with its long-lasting seal for precise fluid delivery, as well as reproducibility from wash to wash.
- User-specified dispense volumes, flow and aspiration rates, and height and depth positioning provide for a wide range of washing capabilities from gentle washing for cellular assays to vigorous washing for ELISA.
- The 50 TS automates the wash steps of most microplate-based assays, including ELISA, fluorescence, chemiluminescence, RIA, polystyrene and biomagnetic microsphere, and cellular assays.
- A "bottom washing" routine for more vigorous washing is available to lower background absorbance when necessary. "Crosswise" or secondary aspiration can be applied to reduce residual volumes.
- The intuitive touchscreen allows you to create and store up to 75 washer protocols. When you are ready to run a protocol, simply select it and follow the screen prompts to wash the plate according to the specified parameters.
- The 50 TS supports Wash, Prime, Dispense, Aspirate, Soak, and Shake protocols.
- Several predefined protocols are provided to simplify maintenance.
- All 50 TS models wash standard 96-well microplates, and some models also wash standard 384-well microplates.
- "V" versions of the 50 TS feature automatic Buffer Switching with three valves.
- The Liquid Level Alert™ option offers the convenience of continuous monitoring of supply and waste bottles. Liquid levels are monitored to ensure there is sufficient wash buffer to complete a microplate wash and sufficient storage capacity in the waste bottle.
- Vacuum Filtration models for filter or membrane microplate assays have a special plate carrier that supports three vacuum levels. 96-well filter-bottom plates with pore sizes from 0.45 µm to 1.2 µm are supported.
- Biomagnetic Separation models support the placement of a magnet beneath the microplate to help retain magnetic beads during aspiration.

Product Support & Service

BioTek's products are backed by a superior support staff. If your instrument ever fails to function properly, or if you need to send the instrument to BioTek for service or repair, please contact our Technical Assistance Center (TAC).

Contacting the Technical Assistance Center

Our Technical Assistance Center is open from 8:30 AM to 5:30 PM (EST), Monday through Friday, excluding standard U.S. holidays. You can send a fax or an e-mail any time.

Phone: 800-242-4685 (in the U.S.) or 802-655-4740 (outside the U.S.)

Fax: 802-654-0638

E-Mail: tac@biotek.com

Please be prepared to provide the following information:

- Your name and company information
- A daytime phone and an e-mail address
- The product name, model, and serial number
- The software part number and basecode version (select **Instrument>Config**)
- To determine problem's cause: the specific steps that produce the problem and any error codes displayed.

■ Alternatively, you may find a solution by reviewing the [Troubleshooting Charts on page 146](#).

Returning Instruments for Service/Repair

If you need to return an instrument to BioTek for service or repair, please contact the TAC for a work order number *before* shipping the instrument. Repackage the instrument properly according to instructions at the end of **Chapter 2, Installation**.

Hardware Features

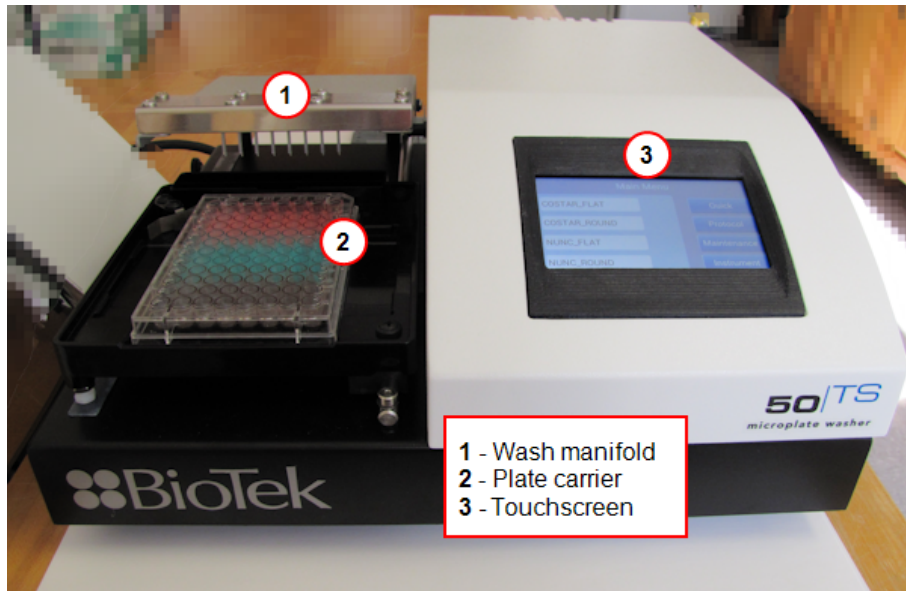

- User Interface: 4.3" LCD touchscreen .
- Washes:
 - 96-well microplates with 0.355" / 9 mm well centers
 - 384-well microplates with 0.177" / 4.5 mm well centers (16 and 16V models only)
 - 96-well filter or membrane microplates (8MF and 8F models only)
 - 1 x 8 or 1 x 12 microwell strips
 - 24-well Corning® 3524 microplates with the optional 4 Well Manifold accessory
- External 24-volt power supply.
- One USB2 port for computer communication.
- Supply and waste systems appropriate for the model/purchased options.
- Internal positive displacement pump provides controllable flow rates and volumes to make washing cellular assays and immunoassays equally convenient. Settings are adjustable via the onboard software, for low to high velocity dispensing.
- Internal vacuum pump aspirates liquid from the microwells into the waste collection vacuum vessel.
- Crosswise (or Secondary) aspiration for optimizing wash performance
- Stepper motors provide accurate and repeatable carrier and manifold positioning, including adjustable aspiration depths to prevent the tubes from touching the well bottom, allowing performance of sensitive cell assays.
- Priming/soaking trough built into the carrier.

- Five shaking speeds for more intense washing.
- 8F and 8MF models: the vacuum filtration carrier evacuates filter or membrane plates. The carrier has a vent port and two vent plugs to control the amount of vacuum applied in filter-plate assays.
- 8M, 8MV, and 8MF models: the biomagnetic separation carrier supports standard microplates with or without a magnet installed.
- Mist shield protects the microplate from contaminants and users from aerosols.

Package Contents

Part	Part Number(PN)
50™ TS Washer	model specific
24 VDC power supply	01281
Power cord	varies by country
Manifold - dispense and aspirate component	varies by type
Microplate carrier - model specific	varies by type
Mist shield	4070517
2-liter supply bottles (two or three)	4070515
2-liter waste bottle	48140
Waste tubing set:	
• All models except 8F, 8M, 8MV, 8MF	4070511
• Models 8F, 8M, 8MV, 8MF	4073002
Supply tubing set	4070510
Manifold stylus kit (for all except the 8,16 Well) ¹	1550506

¹See [Tools for cleaning dispense and aspirate tubes](#) on page 83.

Part	Part Number(PN)
8,16 Well Manifold stylus kit	1550508
Inline vacuum filter	48146
Vacuum pump muffler	4073009
Vacuum Filtration models only — two vent plugs:	
• 0.032" diameter	4072100
• 0.020" diameter	4072099
<i>50™ TS Washer Operator's Manual</i>	1551000

- Part numbers are subject to change. Please contact BioTek Customer Care if you have any questions.

Optional Accessories

Part	Part Number
8 Well manifold	4070512
8s Well manifold (with short tubes)	4070519
12 Well manifold	4070513
8,16 Well manifold	4070527
4 Well manifold (for 24-well plates)	1550504
2x8 Well manifold	1550501
Liquid Level Alert:	

Part	Part Number
• for Buffer Switching models	4070036
• for models without Buffer Switching	4070035
Millipore MSHVN4550 96-well 0.45 µm filter plates	98258
Vacuum filtration plate carrier clamp accessory kit	4070563
Magnet: 96-well Flat (Dexter® LifeSep™)	7103016
Magnet: 96-well Ring (VP®)	7102216
BioTek blue test dye solution for liquid testing (125 mL)	7773001
Wetting agent solution (125 mL)	7773002
Direct Drain Waste System	4070572
50 TS Installation-Operational-Performance Qualification (IQ-OQ-PQ) Package	1550510

Physical Specifications

Microplates and Microwell Strips

Manifold Type	Plates
8 and 8s Well	96-well
12 Well	96-well
8,16 Well	96-/384-well
2x8 Well	96-well
4 Well	24-well

Manifold Type	Plates
<i>Vacuum Filtration</i>	96-well ¹

The 50 TS Washer functions with microplates and microstrips-in-holders that comply with ANSI/SLAS microplate standards 1-2004, 2-2004, 3-2004, and 4-2004 with a maximum plate height of .800" (20.3 mm) and flat, round, or "V" bottom microwells. For example, using the 4 Well manifold 24-well Corning 3524 plates are supported.

Hardware & Environmental

User Interface	4.3" LCD touchscreen
Power Supply	External 24VDC power supply compatible with 100-240 volts AC @50-60Hz.
Power Consumption	40 Watts
Dimensions	15 in. D x 15 in. W x 8 in. H (38 cm x 38 cm x 20.3 cm)
Weight (≤)	20 - 22 lbs. (8.9 - 9 kg) depending on model
Operating Conditions	15° - 40°C (59° - 104°F)
Relative Humidity	The instrument should be operated in a non-condensing humid environment having a maximum relative humidity of 80% at temperatures up to 31°C decreasing linearly to 50% relative humidity at 40°C.
Muffler	A silencing muffler (PN 4073009) to reduce vacuum pump noise is provided. Performance criteria shall be met with the muffler installed.

¹The vacuum filtration "F" and "MF" models wash 96-well filter bottom plates with filter pore sizes from 0.45 µm to 1.2 µm. For example, Millipore® PN: MSHVN4550 (0.45 µm) and PN: MSBVN1B50/P/N MSBVN1210 (1.2 µm).

Bottles

Waste bottle volume: 2 liters (4L optional)
Supply bottle ¹ volume: 2 liters (4L optional)

Liquid-level detection is available as an optional accessory.

Plate Carrier

Carrier	Manifold Types / Instrument Model
Standard	All manifold types except the 8,16 Well / Models: 8, 8V, 8M, 8MV, 8F, 8MF, 12, 12V
384 Well	All manifold types except the 12 Well and 2x8 Well / Models: 16, 16V
Vacuum Filtration	8 and 8s Well manifolds / "F" and "MF" models
Magnetic bead	8 and 8s Well manifolds / "M" and "MF" models

Performance Specifications

Dispense Precision

Manifold Type	Plate Type	Performance
8 and 8s Well	96-well	≤3.0% CV when measured over six 300 µL-per-well dispenses of deionized water with 0.1% Tween 20.
12 Well	96-well	≤3.0% CV when measured over four 300 µL-per-well dispenses of deionized water with 0.1% Tween 20.
8,16 Well	384-well	≤4.0% CV when measured over six 100 µL-per-well dispenses of deionized water with 0.1% Tween 20.
2x8 Well	96-well	≤4.0% CV when measured over six 300 µL-per-well dispenses

¹Buffer-switching "V" models receive 3 bottles; non-"V" models receive 2 bottles

Manifold Type	Plate Type	Performance
		(whole plate) of deionized water with 0.1% Tween 20.
4 Well	24-well	≤4.0% CV when measured over six 1120 µL-per-well dispenses of deionized water with 0.1% Tween 20.

Residual Volume (Evacuation Efficiency)

Manifold Type	Plate Type	Performance
8 and 8s Well	96-well	Average residual of ≤2.0 µL per well after a 3-cycle wash when dispensing 300 µL-per-well using a bottom touching well aspiration and a solution of deionized water with 0.1% Tween [®] 20 or equivalent buffer solution. (The aspirate height should be optimized for the plate prior to testing.)
12 Well	96-well	Average residual of ≤2.0 µL per well after a 3-cycle wash when dispensing 300 µL-per-well using a bottom touching well aspiration and a solution of deionized water with 0.1% Tween 20 or equivalent buffer solution. (The aspirate height should be optimized for the plate prior to testing.)
8,16 Well	384-well	Average residual of ≤4.0 µL per well after a 1-cycle wash when dispensing 100 µL per well using a bottom touching well aspiration and a solution of deionized water with 0.1% Tween 20 or equivalent buffer solution. (The aspirate height should be optimized for the plate prior to testing.)
2x8 Well	96-well	Average residual of ≤4.0 µL per well after a 3-cycle wash when dispensing 300 µL per well using a bottom touching well aspiration and a solution of deionized water with 0.1% Tween 20 or equivalent buffer solution. (The aspirate height should be optimized for the plate prior to testing.)
4 Well	24-well	Average residual volume in the microwells shall be ≤50 µL per well after 1120 µL is dispensed per well , using a near bottom aspiration with a 2000 msec delay, using flat bottomed wells, and deionized water with 0.1% Tween 20 wash solution.

Manifold Type	Plate Type	Performance
Vacuum Filtration (for "F" models)	96-well	Average increased weight of the plate is less than 1.2 grams after dispensing 300 µL of deionized water per well into a Millipore® MSHVN4550 96-well 0.45µm plates (PN 98258) and vacuum aspirated for 30 seconds at vent diameter 0.047" (no plug) and blotted on a paper towel.

Throughput (Processing Speed)

Testing is performed with the Dispense Rate 9 (except: Rate 5 for 2x8 Well and Rate 7 for 12 Well manifold types), Aspirate Rate 7 and using a Strip Wash Format.

Timing is started when the manifold is over the first strip and is stopped when the last strip has been aspirated.

Manifold Type	Plate Type	Performance
8 and 8s Well	96-well	<130 seconds for 12 strips (3 cycles, 300 µL/well, no soak)
8,16 Well	384-well	<260 seconds for 24 strips (3 cycles, 100 µL/well, no soak)
2x8 Well	96-well	<80 seconds for 12 strips (3 cycles, 300 µL/well, no soak)
4 Well	24-well	<60 seconds for a 24-well plate (1 cycle, 1120 µL/well, no soak)
12 Well	96-well	<90 seconds for 8 strips (3 cycles, 300 µL/well, no soak)

50 TS Washer Variations

There are several different 50 TS washer models. “V” version washers include automatic Buffer Switching with three valves. All models support **Liquid Level Alert**.

This table shows some of the features of each model at a glance:

Model	96-Well	96- & 384-Well	Vacuum Filtration	Biomagnetic Separation	Buffer Switching
50TS8	•				
50TS8V	•				•
50TS8M	•			•	
50TS8F	•		•		
50TS8MF	•		•	•	
50TS8MV	•			•	•
50TS12	•				
50TS12V	•				•
50TS16		•			
50TS16V		•			•

Manifold Variations

The **manifold** is the washer component positioned above the microplate that delivers and removes fluid from the microwells. Each 50 TS washer is equipped with a manifold containing paired sets of aspirate and dispense tubes, or “channels.”

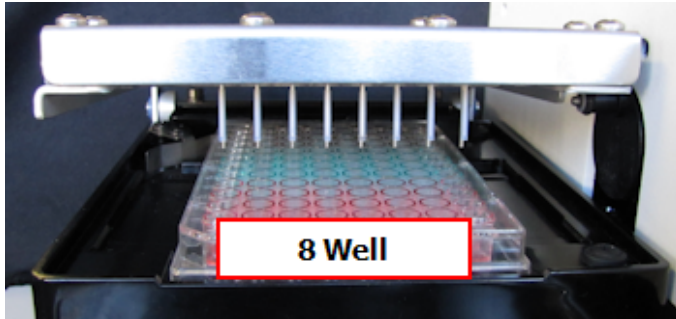

8 Well (or 8s Well)

Supports 8-well strips and 96-well plates.

For use with the standard, magnetic bead, or vacuum filtration plate carriers.

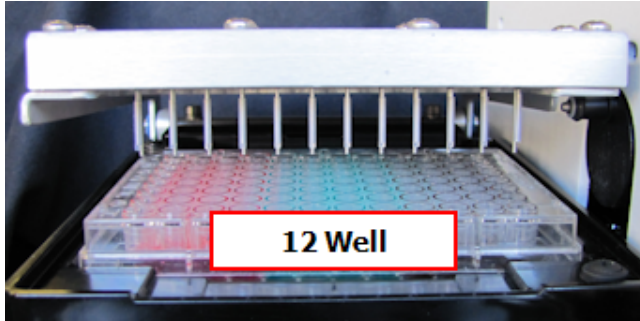

12 Well

Supports 12-well strips, 96-well plates.

Requires the standard carrier.

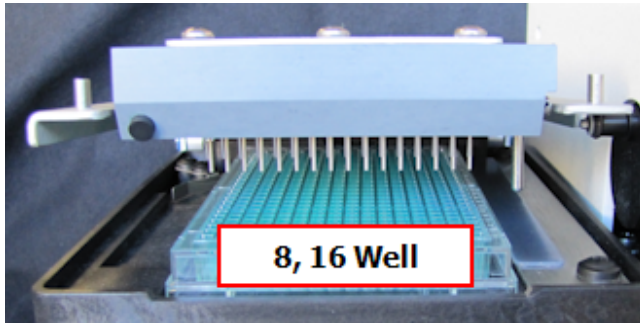

8, 16 Well

For washing 8-well strips, 96-well plates, and 384-well plates.

Requires the 384 plate carrier.

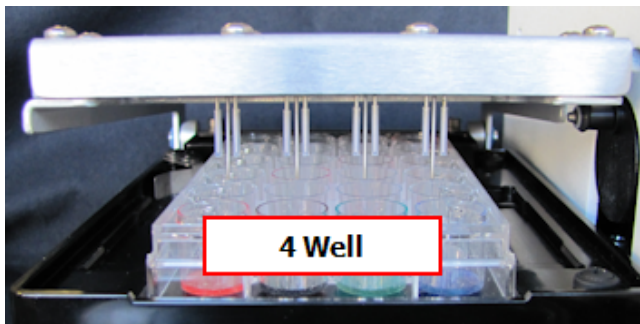

4 Well

For washing 24-well assay plates.

May be used with any plate carrier, but only standard washing or dispensing is supported with the vacuum filtration and magnetic-bead plate carriers.

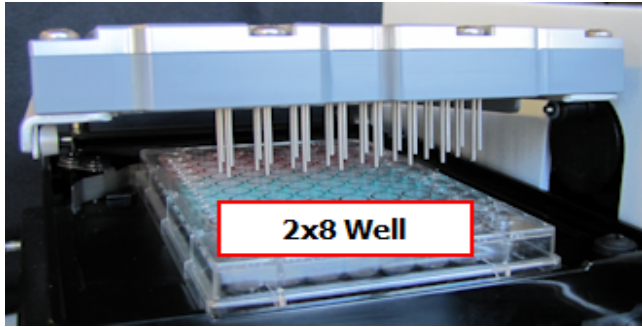

2x8 Well

Washes 96-well plates two strips or columns at a time; an even number of strips must be selected at runtime.

Requires the standard carrier with dual priming troughs.

- The 8s Well manifold has shorter dispense tubes for special applications.
- The 8,16 Well manifold uses two aspirate tubes for each well when addressing 8-well strips and 96-well plates. For these formats, it may be difficult for the tubes to reach the very bottom of round or 'V' bottom wells, possibly leading to higher residuals.
- Vacuum filtration and magnetic bead assays can only be performed when using an 8 or 8s Well manifold.
- The 2x8 Well and 4 Well manifolds are optional accessories.

Important: Make sure the instrument's settings match the installed hardware: manifold and plate carrier.

Plate Carrier Variations

The **plate carrier** transports microplates and positions the wells underneath the manifold tubes. The washer model determines which carrier is shipped with the instrument.

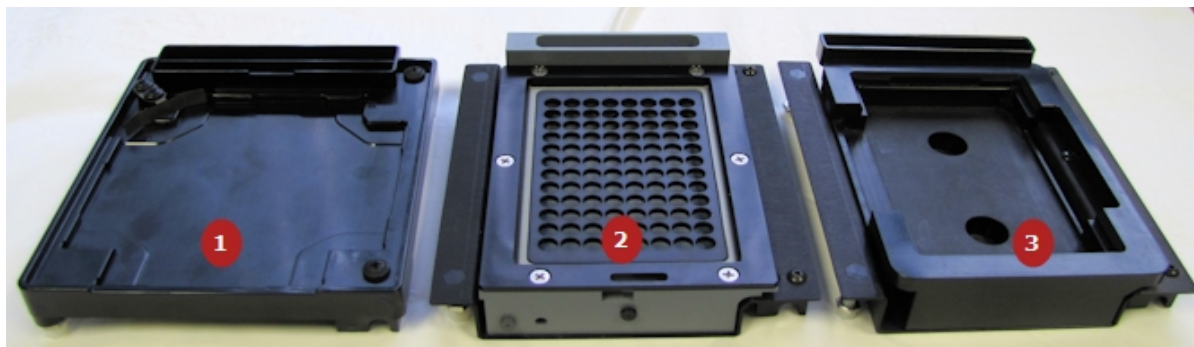

1 = standard/384 carrier; 2 = vacuum-filtration carrier; 3 = biomagnetic-separation carrier (carriers 2 and 3 sit in the plate carrier base)

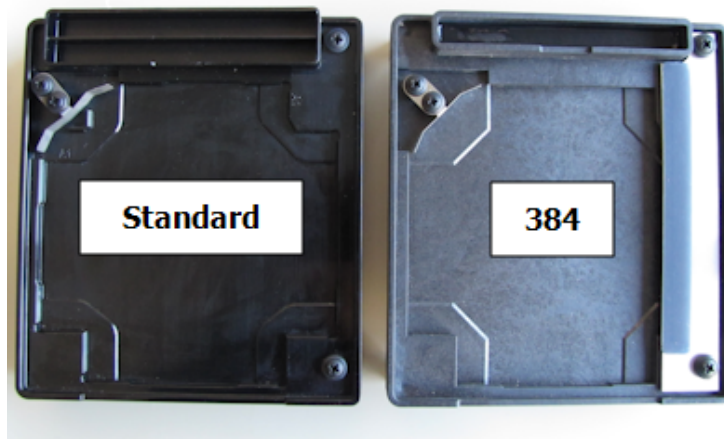
1 – Standard/384 carriers:

- **Standard:** Microplate carrier that supports 8-, 8s-, 2x8, 4 and 12 Well manifolds and solid-bottom plates. It has two priming troughs to support the 2x8 manifold.
- **384:** Microplate carrier that supports 8,16-, 8-, 8s- and 4 Well manifolds and solid-bottom plates. It has a glide strip on the right to support the Dual-Action 16-channel manifold.

2 – With the 8F and 8MF models:

- Vacuum filtration carrier that supports 8- and 8s-channel manifolds and 96-well filter-bottom plates. This carrier evacuates fluid from below the microplate using vacuum filtration.

3 – With the 8M, 8MV and 8MF models:

- Biomagnetic-separation carrier that supports 8- and 8s Well manifolds and 96-well plates. The carrier holds a magnet under the microplate to induce magnetic beads to settle and remain fixed throughout the wash protocol. It also supports processing standard ELISA assays with or without the magnet in place.
- The biomagnetic-separation carrier's priming trough is removable. Make sure the trough is installed before operation.

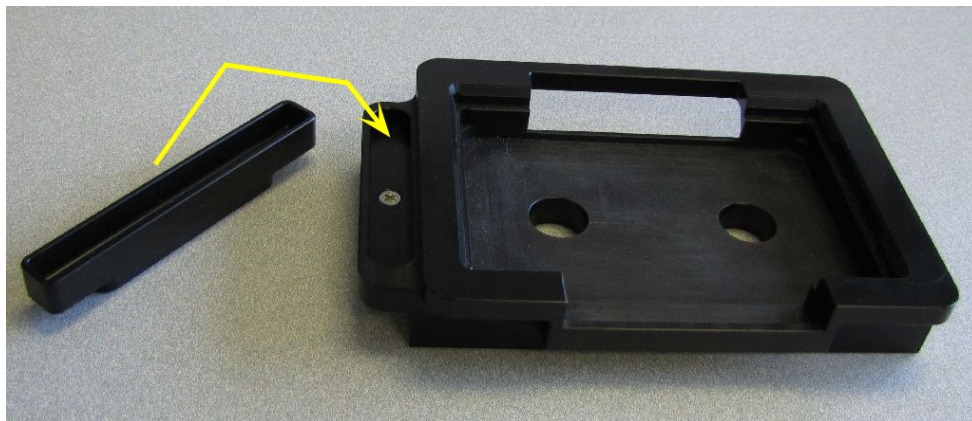

Biomagnetic plate carrier with separate priming trough

Installation

This chapter provides detailed installation instructions.

Unpack and Inspect the Instrument	18
Setting Up the 50 TS	19
Connect the Fluid Supply and Waste System	19
Install the Microplate Carrier	27
Attach the Mist Shield	30
Repacking and Shipping	33

Unpack and Inspect the Instrument

Important: Save all packaging materials. If the washer is shipped to the factory for repair or replacement, it must be carefully repackaged in the original packing materials. Using other forms of commercially available packing materials, or failure to follow the repackaging instructions may **void your warranty**. Improper packaging that results in damage to the instrument may lead to additional charges

Inspect the shipping box, packaging, instrument, and accessories for signs of damage.

If the washer is damaged: Notify the carrier and your BioTek representative. Keep the shipping cartons and packing material for the carrier's inspection. BioTek will arrange for immediate repair or replacement of your instrument.

See **Repackaging and Shipping** at the end of this chapter for complete shipping instructions.

Unpack the accessories and the washer. Washers are shipped with two or three 2-liter supply bottles and one 2-liter waste bottle. The 50 TS with Buffer Switching ("V" version) includes three supply bottles.

Liquid Level Alert™

If you purchased the Liquid Level Alert system, its components are shipped in a separate box.

- For washers with Buffer Switching ("V" version washers), PN 4070036 includes a select box, three 2-liter supply bottles, and one 2-liter waste bottle.
- For washers without Buffer Switching, PN 4070035 includes a select box, one 2-liter supply bottle, and one 2-liter waste bottle.

Setting Up the 50 TS

Important: Avoid **excessive humidity**. Condensation directly on the sensitive electronic circuits can cause the instrument to fail internal self checks.

Important: The manifold dispense tubes have a protective Teflon collar at the tip. This is to prevent dripping. **Do not remove these coverings!**

Operating Environment

The 50 TS washer is sensitive to extreme environmental conditions. For optimal operation, install the washer:

- on a stable, level surface,
- in an area where temperatures between 15° - 40°C (59° - 104°F) can be maintained, and
- away from excess humidity.

Connect the Fluid Supply and Waste System

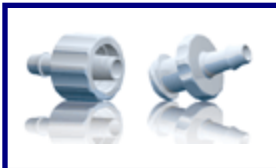

Caution. The washer manifold, the vacuum port, and the supply bottles have Luer fittings. **Finger-tighten only!!**

Place the supply and waste bottles on the same horizontal plane as the washer. This ensures optimum pump performance.

■ **Liquid Level Alert System:** If you purchased the optional level alert accessory, use the special supply and waste bottles provided with the kit during this installation procedure. Unlike the standard bottles, the liquid level alert bottles have a sensing device inside, connected to an electrical cable in the top. When the washer is installed, follow the instructions to enable the system, See [Install the Liquid Level Alert System \(Optional\)](#) on page 24.

Connect the Fluid Supply

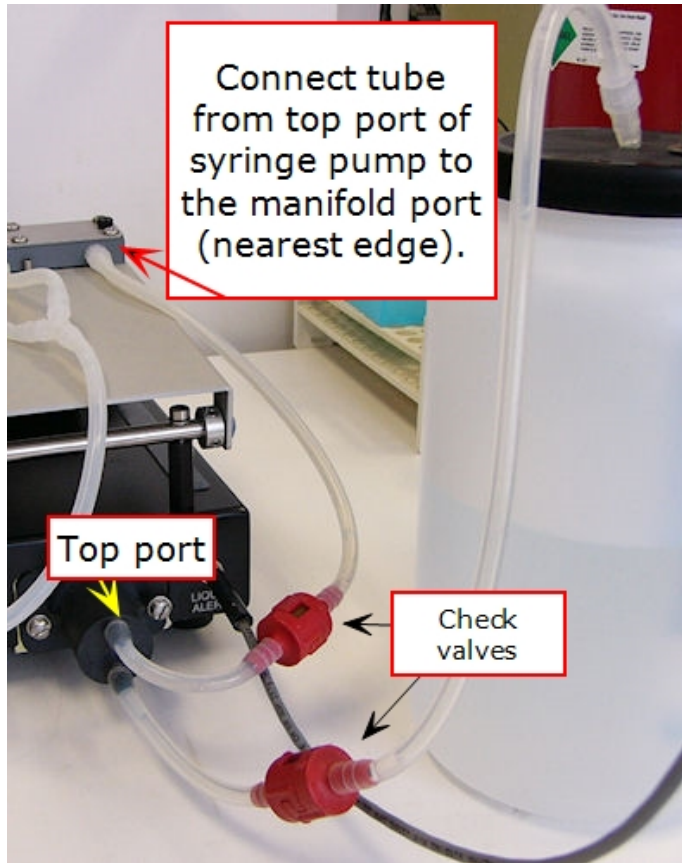

Fluid Supply without Buffer Switching is shown in this photo. The tubing connects directly from the bottle to the syringe pump to the wash manifold.

1. Locate the tubing with the check valves used for the fluid supply, PN: 4070510.
2. Connect the short tube to the top port of the syringe pump and to the port on the wash manifold nearest the edge. Make sure the flow arrow on the check valve points towards the manifold.

3. Connect the long tube to the bottom port of the syringe pump. This is the fluid supply "Input." Make sure the flow arrow points toward the washer.
4. **Without Buffer Switching:** Connect the long tube to the top of the supply bottle.

With Buffer Switching: The tube will extend only from the syringe pump to the Valve Output port next to the pump.

1. First, remove the Luer fitting on one end of the tube and cut the long tube to about 5" (12.7 cm) from the check valve.
2. Reinsert the Luer fitting and connect it to the Valve Output port on the back of the washer.

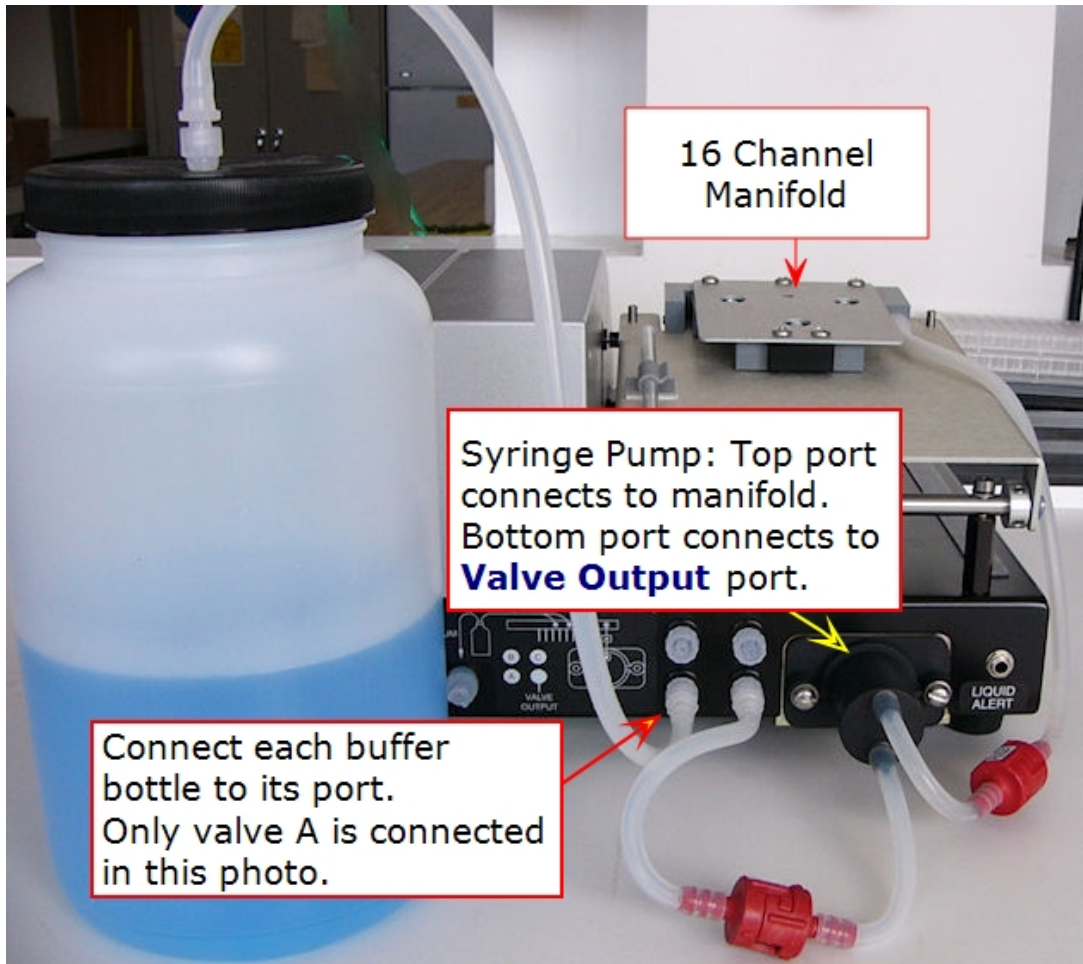

Fluid supply **with** Buffer Switching: tubing connects to internal valves

5. Connect the three supply bottles, A, B, C, to their respective ports.

Connect the Waste System

- Finger-tighten only all fittings!

All 50 TS models except 8MF and 8F:

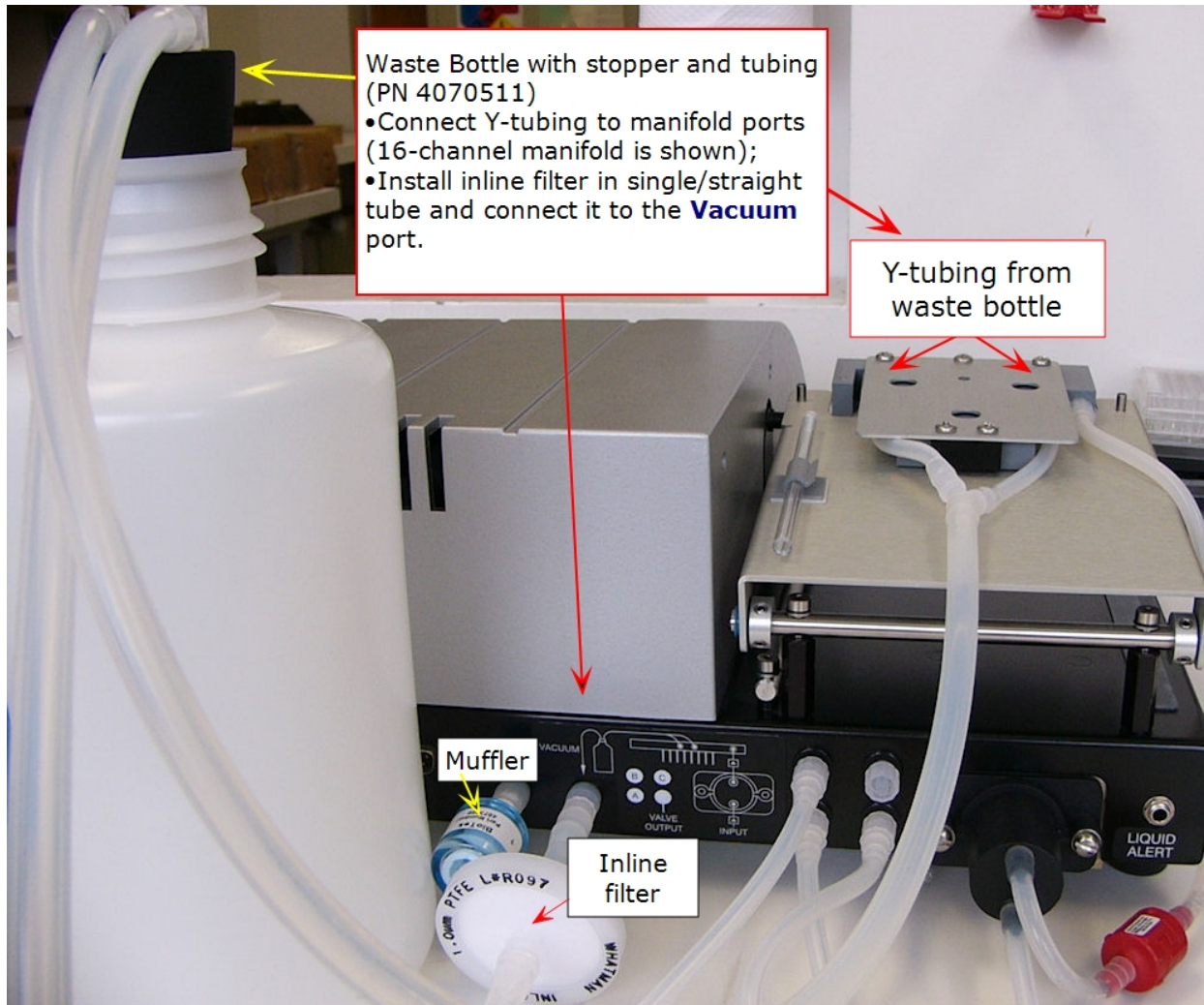

Connecting the Waste system tubing on the back of the washer

1. Remove the waste bottle cover and replace it with the stopper from the waste tubing set.
2. Attach the Y-shaped tubing from the waste bottle stopper to the two waste ports on the back of the wash manifold.

3. Install the **inline vacuum filter**:

1. Cut the tubing that will connect the waste bottle to the **Vacuum** port: leave about an inch of tubing extending from the Luer fitting that will connect with the washer.
2. Insert the vacuum filter between the cut ends of the tubing.

■ The inline vacuum filter (PN: 48146) is optional but strongly recommended to (1) prevent waste material aerosols from escaping into the air, and (2) to serve as a *temporary* fluid barrier if the waste bottle is allowed to overfill.

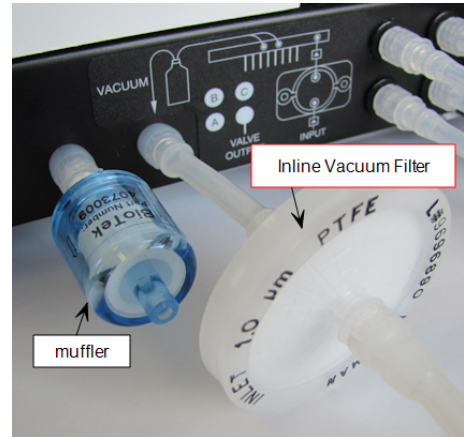

4. (After inserting the inline vacuum filter) Connect the tubing from the waste bottle to the **Vacuum** port on the back of the washer.

50 TS/8F and 8MF models (for vacuum filtration)

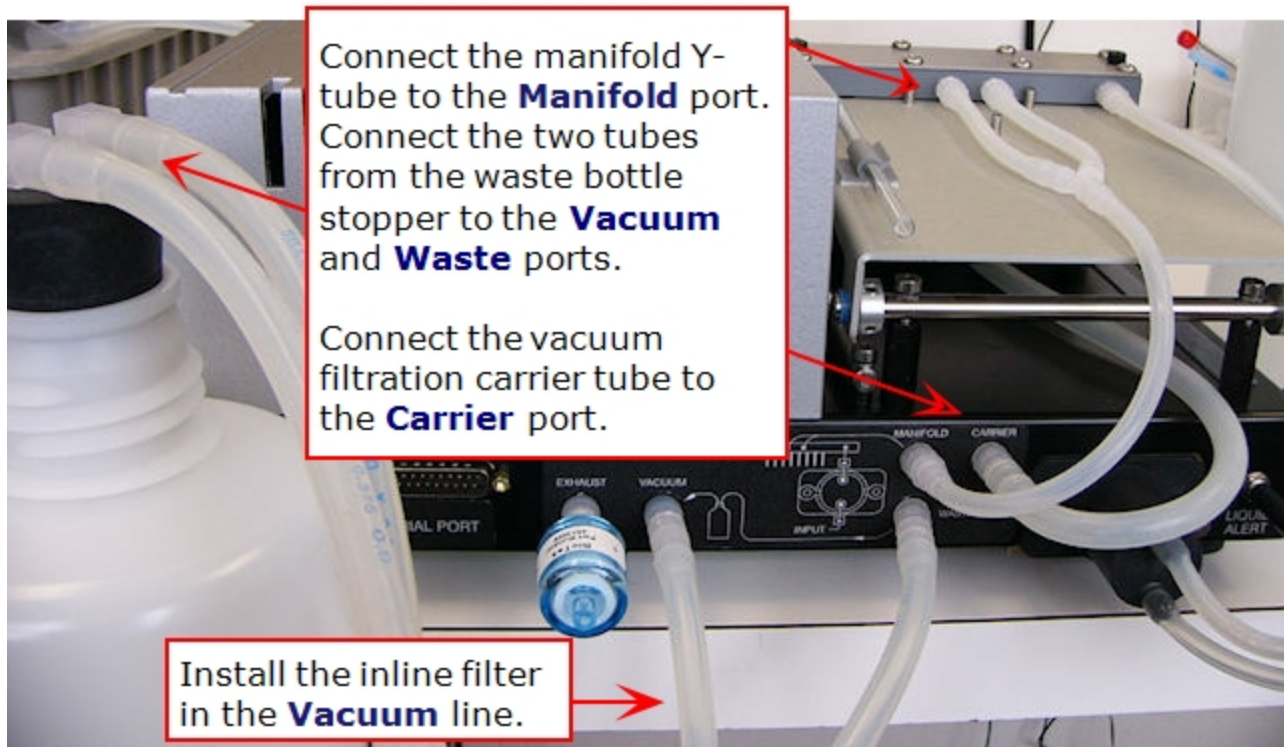

Installing the Waste system for vacuum filtration models: 8F and 8MF models.

1. Attach the Y-shaped tubing to the two waste ports on the back of the wash manifold (two center ports).
2. Connect the end of the Y-waste tubing to the **Manifold** port on the back of the washer.
3. Remove the waste bottle cover and replace it with the stopper from the waste tubing set. Take note of the distinct fittings at the end of each tube: one connects to the **Vacuum** port, the other to the **Waste** port on the back of the washer.
4. To install the optional inline vacuum filter:
 1. Cut the tubing that will connect the waste bottle to the **Vacuum** port leaving about an inch of tubing extending from the washer,
 2. Insert the vacuum filter between the cut ends of the tubing.
5. Attach the tubing from the waste bottle to their respective ports on the back of the washer:
 - **Vacuum** port to connect the vacuum pump to the waste bottle,
 - **Waste** port to capture waste fluid from the washer.
6. Connect the tubing from the vacuum filtration carrier to the **Carrier** port on the back of the washer.

■ Disconnect the waste tube from the **Carrier** port when you are not using the vacuum filtration carrier. An internal valve preserves the vacuum required to perform standard aspiration.

Install the Liquid Level Alert System (Optional)

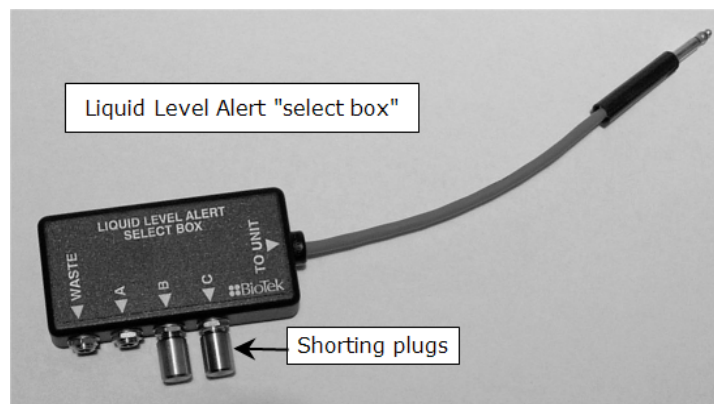

The Liquid Level Alert **select box** has ports, labeled A, B, and C, for the supply bottles, and Waste.

1. If you have not already done so, connect the waste and fluid supply bottles as described on the previous pages.
2. Connect the cables from the supply and waste bottles to the select box:
 - For washers **with Buffer Switching**, connect the supply bottle cables to the appropriate ports in the select box. If a port is left empty, insert one of the supplied "shorting plugs" (all ports must be filled).
 - For washers without Buffer Switching, connect the supply bottle cable to port A and then insert the shorting plugs into ports B and C.
 - For all washers, connect the waste bottle cable to the WASTE port.
3. Connect the select box to the **LIQUID ALERT** port on the back of the washer.
4. Enable Liquid Level Alert by selecting: **Instrument>Options** and making **Liquid Level Alert Enabled**.

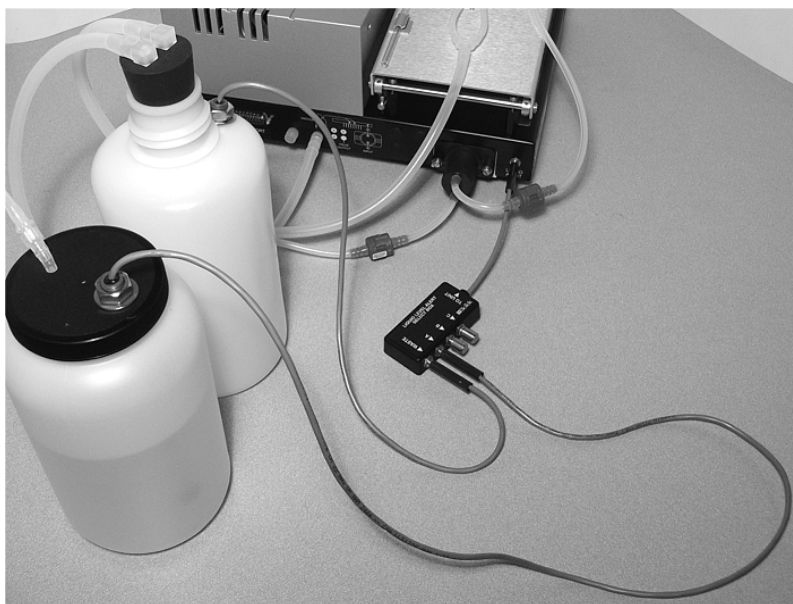

Liquid Level Alert Setup

Install Vacuum Pump Muffler (Optional)

Install the optional vacuum pump muffler (PN 4073009) to reduce noise during operation.

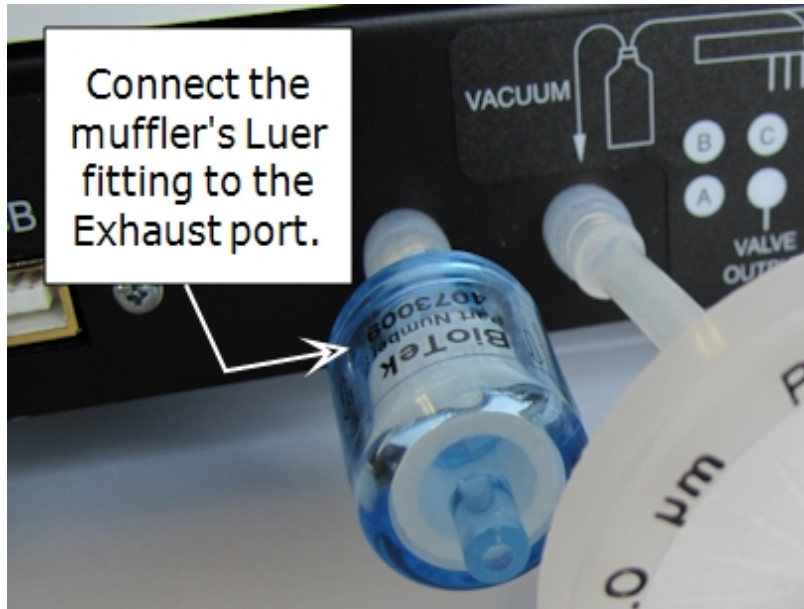

Connect the muffler's Luer fitting on to the **Exhaust** port (in between the USB and vacuum ports) on the back of the washer.

Install the 8, 8s, 12, 2x8, or 4 Well Manifold

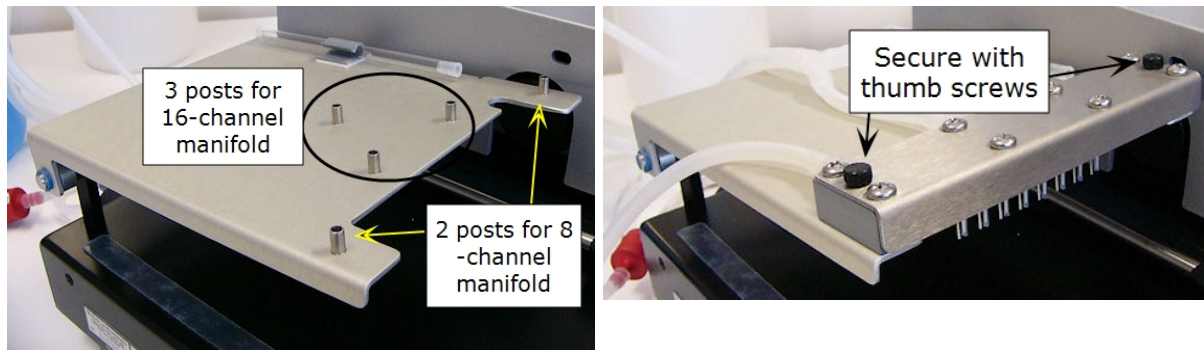

To install any manifold except the 8,16 Well manifold: rest it on the two outer posts and secure with thumbscrews

1. Orient the manifold with the aspirate and dispense tubes facing down, and the fittings for the supply and waste tubing facing the back of the washer.
2. Place the manifold gently onto the two support pins on the manifold mounting bracket closest to the front of the washer.
3. Insert the thumbscrews (2). Do not overtighten.

See also **Connect the Fluid Supply and Waste System** [page 19](#) for descriptions of the manifold tubing connections.

Install the 8,16 Well Manifold

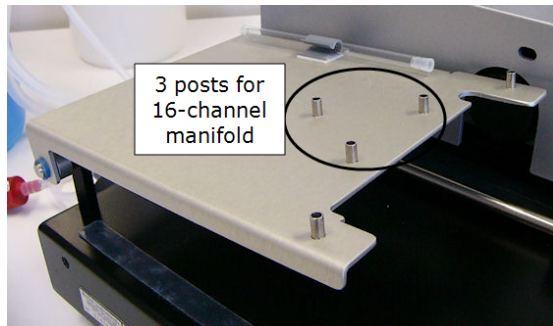

Secure the 16 Well manifold on the 3 posts with the 3 thumb screws.

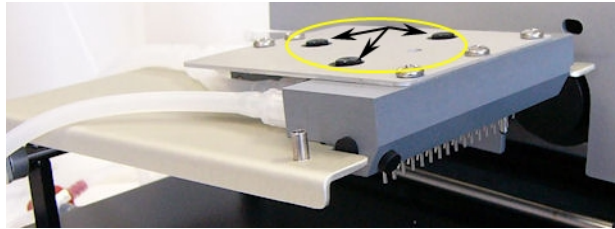

1. Orient the manifold with the aspirate and dispense tubes facing down, and the fittings for the supply and waste tubing facing the back of the washer.
2. Place the manifold gently onto the three support pins on the manifold mounting bracket.
3. Insert the thumbscrews (3). Do not overtighten.

See also Connect the Fluid Supply and Waste System on page 19 for descriptions of the manifold tubing connections.

Install the Microplate Carrier

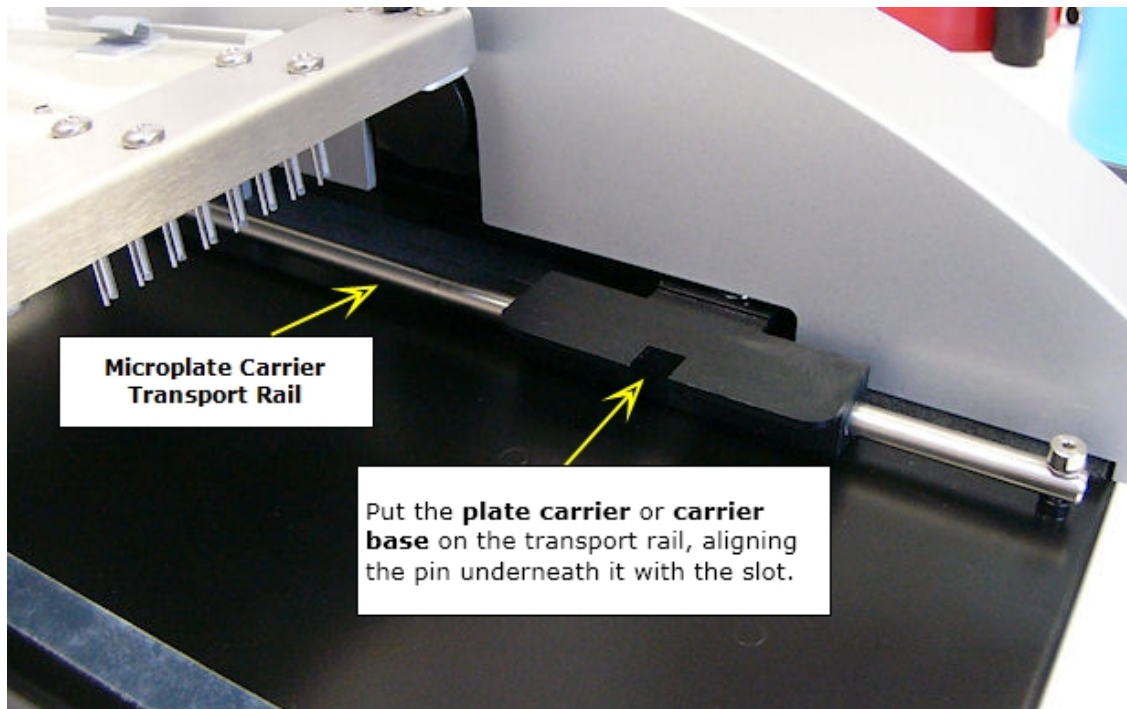

1. Position the microplate carrier or the carrier base of “F” and “M” models so the priming trough is closest to the rear of the washer.
2. Line up the pin on the underside of the carrier with the slot on the carrier transport rail and install the carrier. Rail guides under the carrier sit on rail.

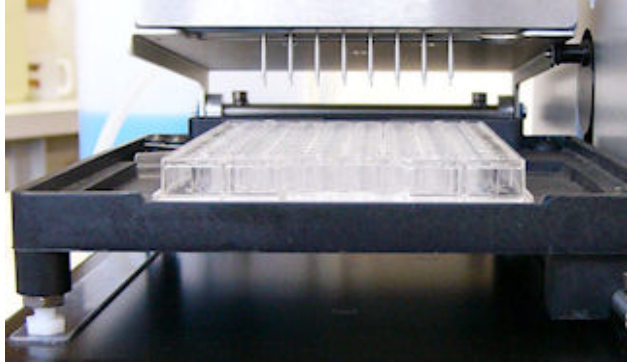

Standard microplate carrier with plate

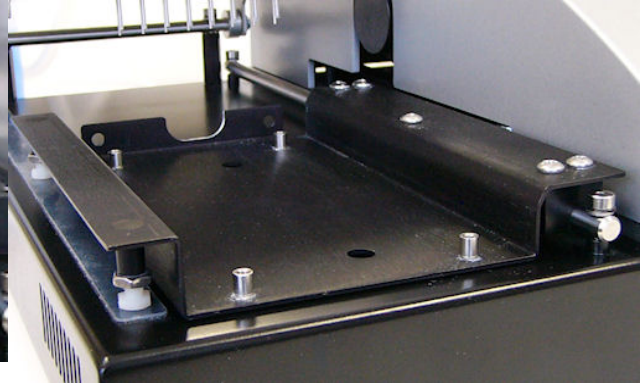

Base for mag bead & vac filtration plate carriers

Vacuum Filtration and Biomagnetic Separation Carrier

The 50 TS: “F” or “M” models ship with one or two microplate carriers which fit into the microplate carrier base.

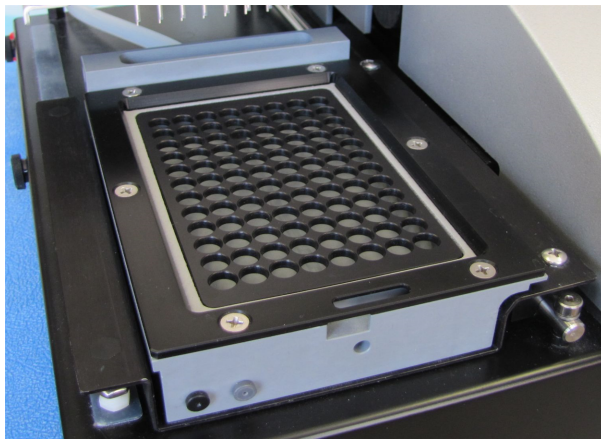

Vacuum filtration plate carrier

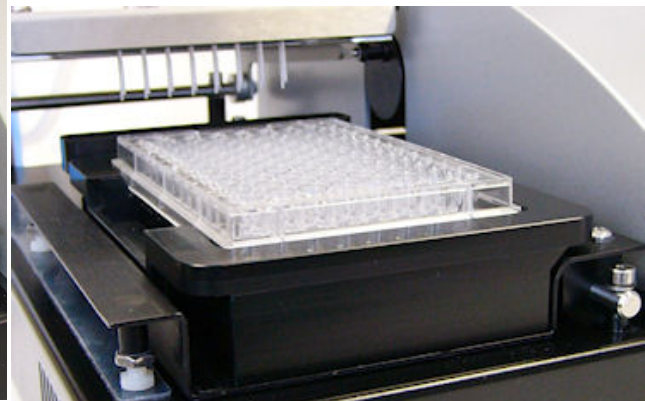

Biomagnetic separation plate carrier

1. Install the microplate carrier base as described above; except 8F models: the vacuum filtration carrier is already attached to the carrier base.
2. Observe on the underside of the vacuum filtration and biomagnetic separation carriers the holes for pins in each of the four corners. Align the carrier to fit on top of the pins in the carrier base.
3. Vacuum filtration carrier: connect the tubing on the special plate carrier to the Carrier port on the back of the washer.

- The biomagnetic-separation carrier's priming trough is removable. Make sure the trough is installed before operation.

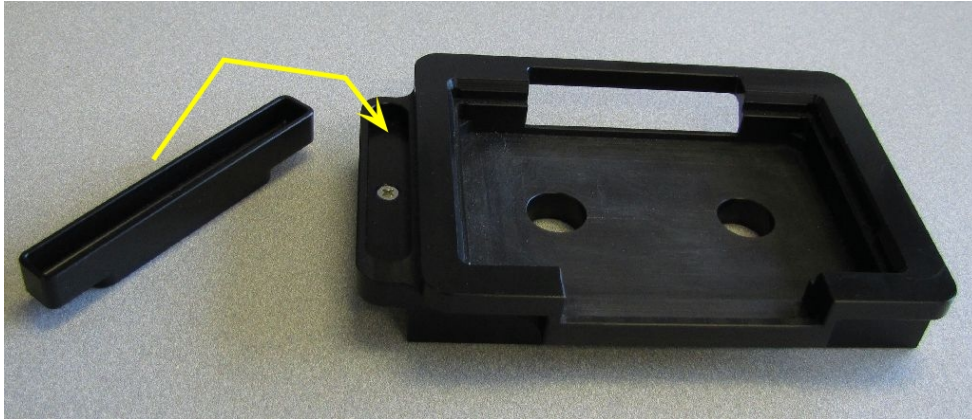

Biomagnetic plate carrier with separate priming trough

- For **vacuum filtration** and **biomagnetic separation assays**, install the 8- or 8s Well manifold.
- Disconnect the waste tube from the **Carrier** port when you are not using the vacuum filtration carrier. An internal valve preserves the vacuum required to perform standard aspiration.

Installation Final Check

1. Verify that the tubing was not crimped during installation.
2. Make sure the fluid supply and the waste output tubes are attached to the appropriate manifold ports. Lift the manifold mounting bracket up or back to make sure the tubing to the manifold is not being pulled too tightly.
3. Vacuum Filtration models: make sure there is sufficient room behind the washer for the waste tubing attached to the special carrier to move during operation.

Attach the Mist Shield

The mist shield is also called the aerosol cover.

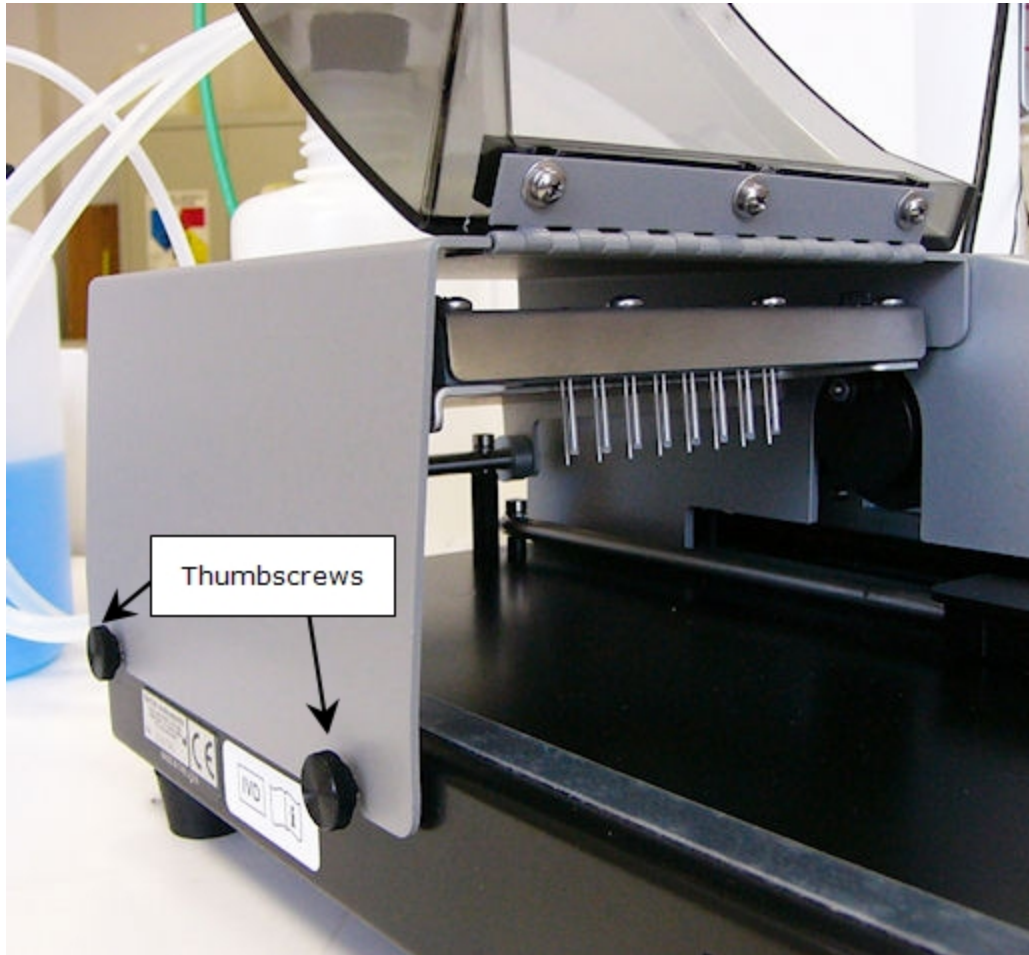

Mist Shield: open

1. Insert the two thumbscrews into the slots on the washer's left side. Do not tighten completely.
2. With the door toward the front of the washer, slide the mist shield down onto the thumbscrew shafts and insert the two pins on the right side into the slots on the top left side of the instrument cover.
3. Tighten the thumbscrews.



Mist Shield: closed

Connecting the Power Supply and Cord

	<p>Warning! Power Rating. The 50 TS power supply must be connected to a power receptacle that provides voltage and current within the specified rating for the system. Use of an incompatible power receptacle may produce electrical shock and fire hazards.</p>
	<p>Warning! Electrical Grounding. Never use a two-prong plug adapter to connect primary power to the 50 TS power supply. Use of a two-prong adapter disconnects the utility ground, creating a severe shock hazard. Always connect the power cord directly to a three-prong receptacle with a functional ground.</p>

The 50 TS Washer uses an external 24-volt power supply. The power supply automatically adjusts for input voltage in the range of 100 - 250 V~.

1. Plug the power supply's plug into the washer's rear panel.
2. Insert the power cord into the power supply and into an appropriate wall outlet.

Verify Performance

Before using the 50 TS washer for the first time, verify that it is operating properly by turning the washer on. Turning on the washer initiates a system Self-Test to check the manifold, microplate carrier, vacuum pump and syringe pump positioning and operation.

When the self test has completed successfully, the washer is ready for use.

If the test passes, the Main Menu is displayed.

If the test fails, the washer beeps repeatedly and displays an error code. If this happens, note the error code and then press **Stop** on the keypad to stop the beeping. Look up **Error Codes on page 134** to determine its cause. If the problem is something you can fix, turn off the washer, fix the problem, and then turn the washer back on. Otherwise, contact BioTek's Technical Assistance Center.

The **Qualification Chapter** beginning on [page 99](#) provides recommended procedures to perform after the instrument is installed and set up as described in this chapter, and *before* the instrument is used in a laboratory environment.

The successful completion of the Installation Qualification confirms that the washer and its components have been supplied as ordered and ensures that they are assembled and configured properly for your lab environment. The successful completion of the Operational Qualification confirms that the washer is operating according to specification.

■ **Note:** An **instrument qualification package** (PN 1550510) for the 50 TS is available for purchase from BioTek. The package contains thorough procedures for performing Installation Qualification, Operational Qualification and Performance Qualification (IQ/OQ/PQ) and preventive maintenance (PM). Extensive Checklists and Logbooks are included for recording results. Contact your local dealer for more information.

■ **Important!** Review [Optimize Performance on page 44](#), which describes necessary steps to perform before running the washer.

Repacking and Shipping

If you need to ship the 50 TS to BioTek for service or repair, be sure to use the original packing materials. Other forms of commercially available packing are not recommended and can void the warranty.

If the original packing materials have been damaged or lost, contact BioTek and ask for part number 1553004.

- The instrument's packaging design is subject to change over time. If the instructions in this section do not appear to apply to the packaging materials you are using, please contact BioTek's Technical Assistance Center for guidance.

1. Before Repackaging the Instrument

Important: Perform the following steps before shipping the washer



Warning! If the washer has been exposed to potentially hazardous material, decontaminate it to minimize the risk to all who come in contact with the washer during shipping, handling and servicing. Decontamination prior to shipping is required by the U.S. Department of Transportation.

1. Decontaminate the washer and its accessories as necessary. See [Decontaminate the Washer on page 87](#) for instructions.
2. Obtain a work order number from BioTek's Technical Assistance Center. Have your instrument's serial number ready when you call.
3. When obtaining the work order number, explain whether the washer requires calibration, cleaning, periodic maintenance, warranty work, and/or repair. Make a note of any error messages displayed and their frequency.
4. Provide BioTek with the name and contact information of a person who may be contacted if questions arise.
5. Mark the work order number on the outside of the shipping box.
6. Insure the instrument for full value before shipping it to BioTek.

2. Disassemble and Repack the Components

After decontaminating the instrument, carefully remove and repack the components:

1. Turn the washer off, disconnect the power supply cord and all waste and supply tubing from the washer.
2. Remove the mist shield and place it into a plastic bag. Retighten the two thumbscrews that hold the mist shield in place.
3. Remove the manifold, beginning with the thumbscrews. For the 8-, 8s-, or 12-channel manifolds only: Screw the two thumbscrews back into their support pins.
4. Pack the manifold as shown:

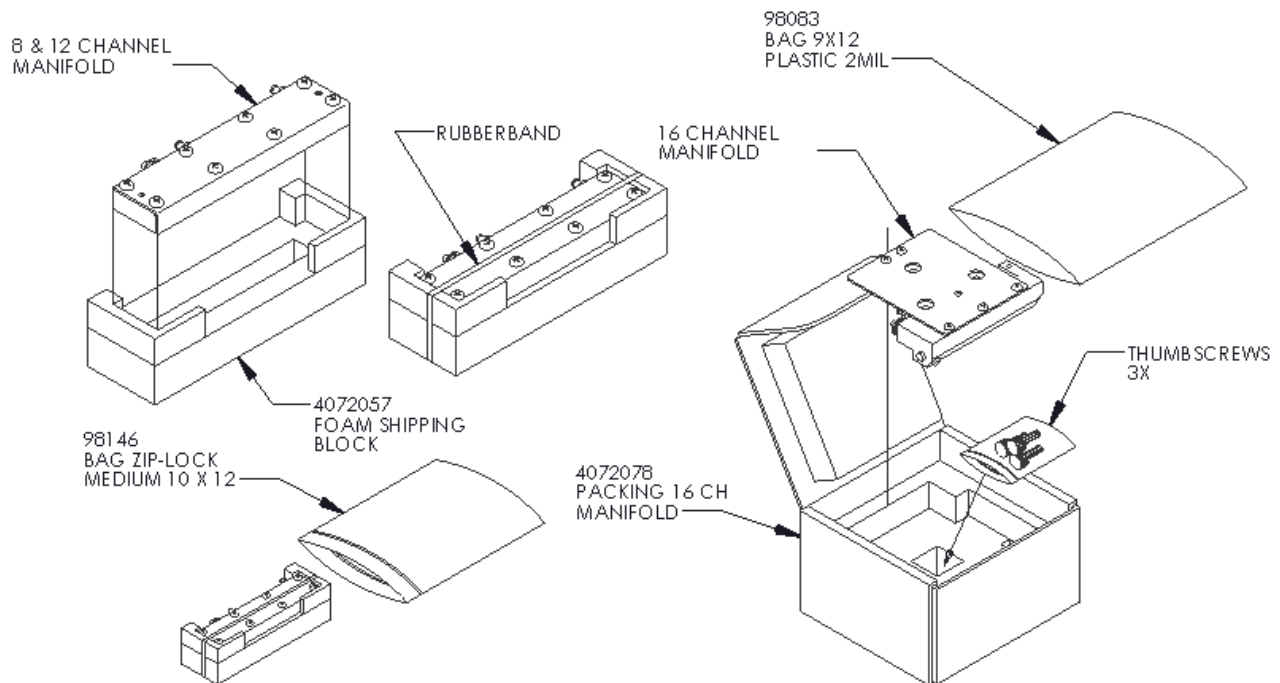

5. Remove the microplate carrier and place it in a plastic bag.

3. Rotate the Cam and Install Shipping Block

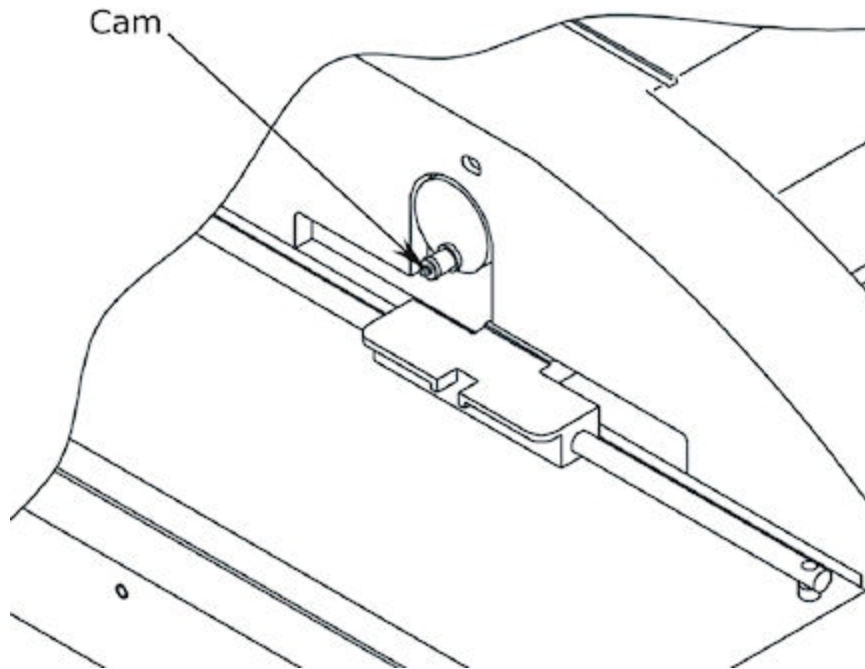

After removing the mist shield, manifold, and plate carrier, rotate the cam until it is in the downward position, as shown.

1. After removing the components, rotate the cam until it is in the downward position.
2. Insert the manifold shipping block, aligning the groove in the top of the block to cushion the manifold bracket.

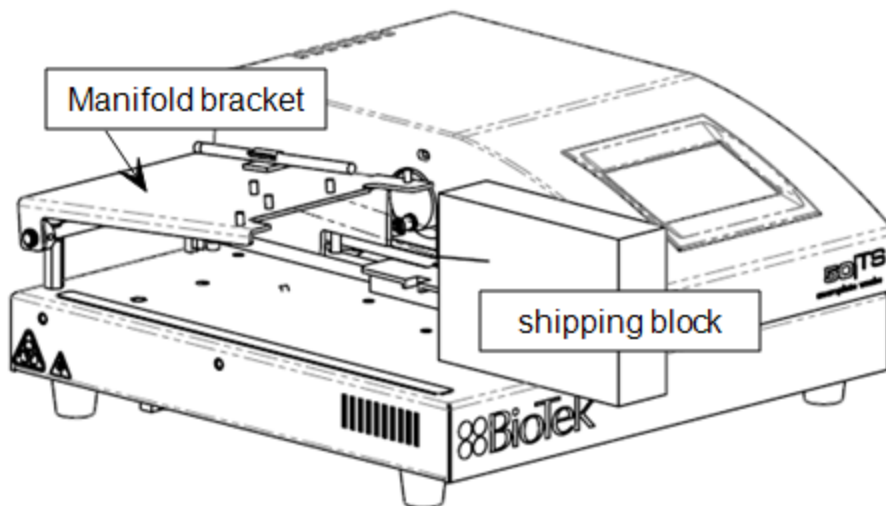

Align the groove in the shipping block with the manifold bracket and slide it into place.

3. Put the washer into a plastic bag.

4. Pack the Washer and Components

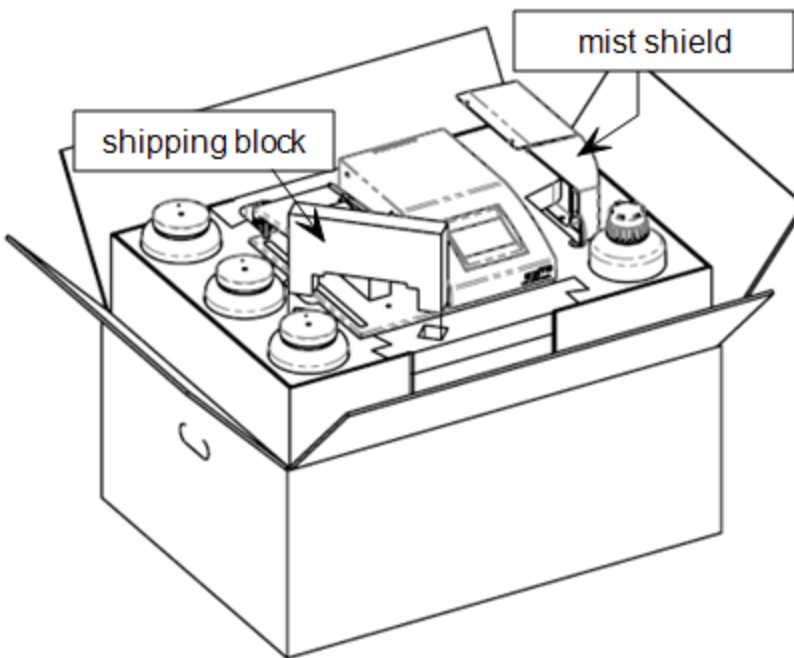

1. Pack the washer, supply and waste bottles, and the mist shield into the lower shipping tray and insert the shipping block into its square pockets. And, put the tray inside the box the washer was shipped in.
2. Lastly, put the accessories tray on top of the lower shipping tray and fill it with the remaining components, e.g. manifold, plate carrier, tubing, and so on.
3. Cover the top layer with piece of cardboard.
4. Tape up the box, if applicable, write the work order number on the outside and ship it to BioTek.

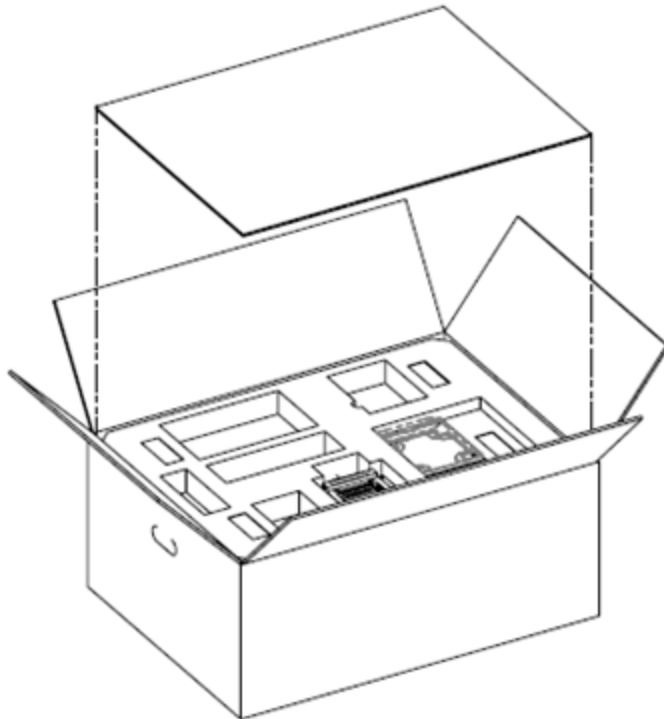

Operation

This chapter provides instructions for controlling the washer.

Prime Options	38
AutoPrime	40
Wash a Plate	41
Optimize Performance	44
Run a Predefined Protocol	45
Create a Protocol	50
Special Applications	58
Instrument Configuration - Setup Controls	66

Prime Options

Priming the tubing accomplishes several goals. Removing air bubbles from the tubing is essential for accurate dispensing. Flushing the tubing when changing fluids ensures buffer purity. Keeping the dispense tips wet prevents clogs, especially when using buffers that crystallize when dry. Priming is the primary maintenance task, flushing the tubing with a cleanser and/or DI water.

Important: Always prime the washer before washing plates/strips.

The 50 TS offers numerous ways to prime the tubing:

Priming Options	How to
Quick Prime on the facing page	Select Quick at the Main Menu .
Priming in a Wash Protocol	Select Protocol at the Main Menu and "edit" a protocol to "Add" a stand-alone Prime step or "edit" a Wash step to include a prime before and/or between cycles.
Onboard Maintenance Prime Programs on page 73	Select Maintenance at the Main Menu .
Autoprime on page 40	Select Instrument at the Main Menu and enable and define settings.

Dead Volume

Consider these approximate dead volumes when defining priming values to adequately prime the tubing before running a wash or dispense protocol. BioTek recommends priming with two or three times the dead volume for a dry instrument and when changing fluids. For example: dead volume (20 mL washer + 5 mL manifold) x 2 = 50 mL prime volume.

Washer/Manifold	Dead Volume
50 TS without Buffer Switching	20 mL

Washer/Manifold	Dead Volume
50 TS with Buffer Switching ("V" models) with full 28" supply tubing	35 mL
50 TS "V" model with supply tubing cut to 8"	25 mL
All manifolds except the 2x8 Well manifold	5 mL
2x8 Well manifold	10 mL

Quick Prime



Select **Quick>Prime**.

BioTek defines two types of prime:

- **Manifold:** uses a smaller amount of fluid to condition the dispense tips.

Press the "Priming for" button to run a manifold prime immediately before a wash or dispense step to correct for evaporation between runs.

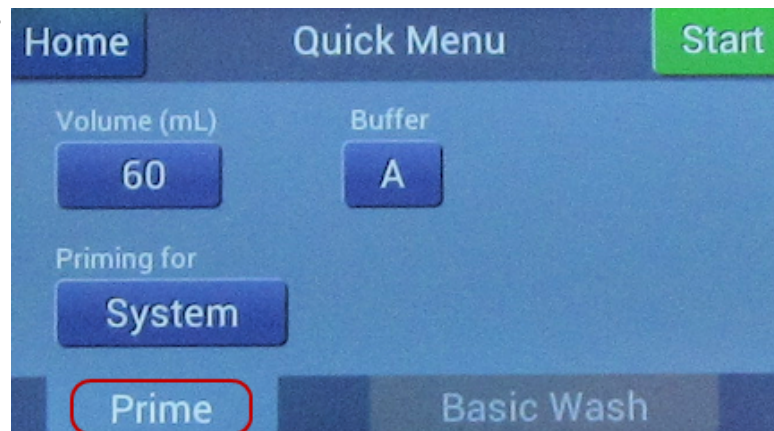

- **System:** priming is necessary when changing fluids, and at the start and end of the day to flush the tubing. Except buffer switching models should run the System option when the instrument has been idle between runs.



Best practice: for the most precise dispense volumes, always run a "Quick Manifold Prime" before a basic wash or dispense. Buffer Switching models may require a "System" prime if the instrument has been idle.

AutoPrime

LHC: Tools>Instrument Utilities> AutoPrime

From the Home screen: Instrument>AutoPrime

Recommended for optimum performance, AutoPrime keeps the tubing wet in between runs and can be an essential part of your daily maintenance routine.

About AutoPrime

AutoPrime automatically primes the tubing whenever the instrument is idle for a specified time. Keeping the tubes wet prevents clogging and mitigates fluid evaporation at the tips. AutoPrime's submerge feature lets you soak the tubes for extended periods, which is an effective maintenance option.

Specify the Interval and AutoPrime Parameters

AutoPrime only runs when the Main Menu (Home) is displayed and the instrument has been idle for a specified interval.

To set **AutoPrime**:

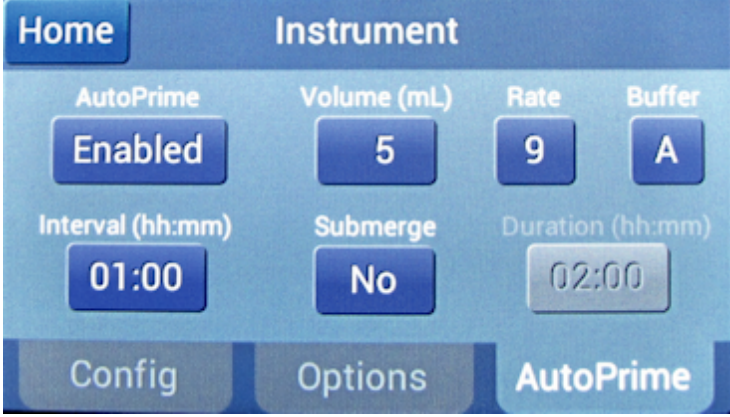
Touchscreen:	LHC:
1. Select Instrument at the main menu and select AutoPrime .	1. Select Tools>Instrument Utilities> AutoPrime tab.
	2. "Enable" AutoPrime and specify the parameters: <ul style="list-style-type: none"> the idle-time interval that will trigger priming; up to 24 hours. Set the Submerge Duration, if desired. Flow rate, volume, and buffer valve, if applicable. 3. LHC users: click Send to transfer the settings to the instrument.

Wash a Plate

Two ways to wash a plate:

- **Quick Wash:** use the Quick menu to wash strips or a plate using default instrument settings.
- **Protocol:** run a predefined wash protocol: touch your choice on the **Main Menu**. Protocols let you customize the wash parameters to improve assay performance.

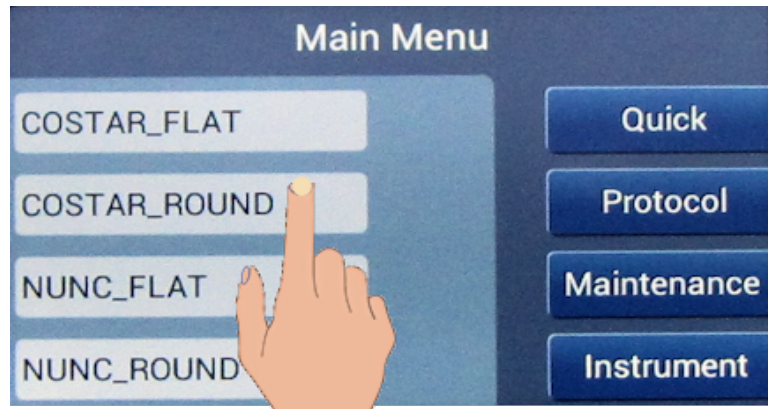

Quick

Quick Wash

Press **Quick** at the Main Menu (Home) to **Prime** the tubing and run a **Basic Wash**.

- **Prime:** two options for the most common daily uses: **System** to prime all the tubing, when changing buffers, for example, and **Manifold** to prime the dispense tips to correct for evaporation.
- **Basic Wash:** after priming the tubing, specify the volume-per-well, buffer bottle, if applicable, number of wash cycles and how many strips (or rows) to wash.

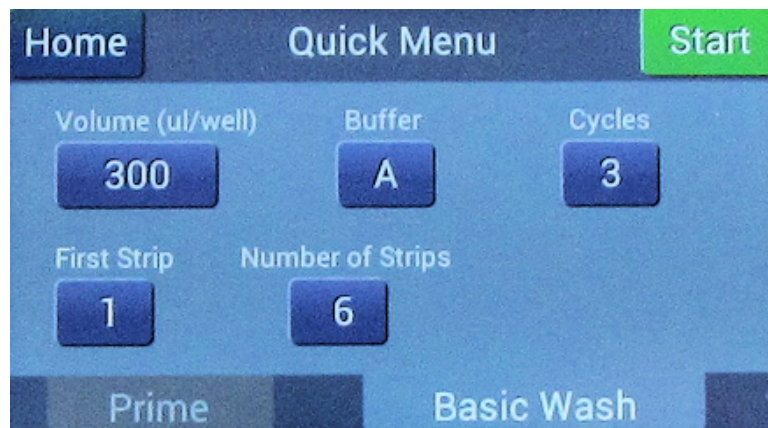

When you are ready to wash a plate:

1. Fill the supply bottle and connect it to the washer, (empty the waste bottle, if necessary).
2. Prime the tubing: use **Quick Prime** or run a **Maintenance** protocol.
3. Properly seat the microplate or microstrips holder in the plate carrier with well

A1 closest to the manifold/dispense tips.

4. Press .

Protocol

Wash Protocol

Predefined protocols, including sample protocols provided with the 50 TS reside on the Main Menu. Touch a protocol to run it.

See [Create a Protocol](#) on page 50.

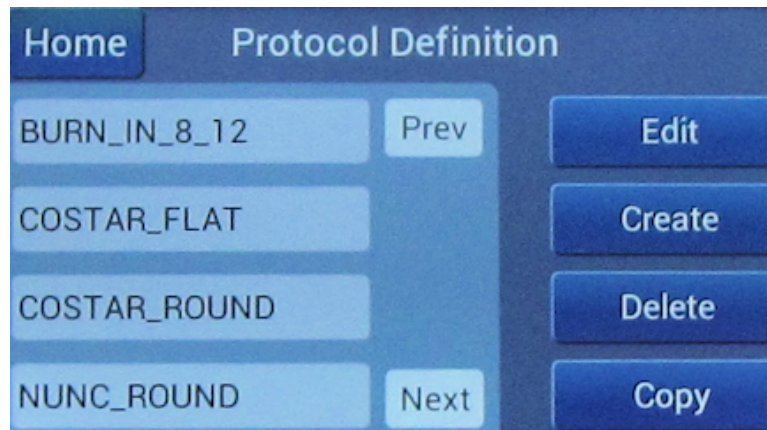

If more precise positioning of the aspirate tubes, more or fewer wash cycles, or a slower aspirate travel rate would improve your results, e.g. reduce residuals, use the Protocol menu to customize a protocol for your assays. Several sample protocols are provided, which can be used as templates to give you shortcut to creating your own protocols. "Copy" a sample protocol to preserve the original, and start the customization with optimized parameters for the plate type.

About Wash Protocols

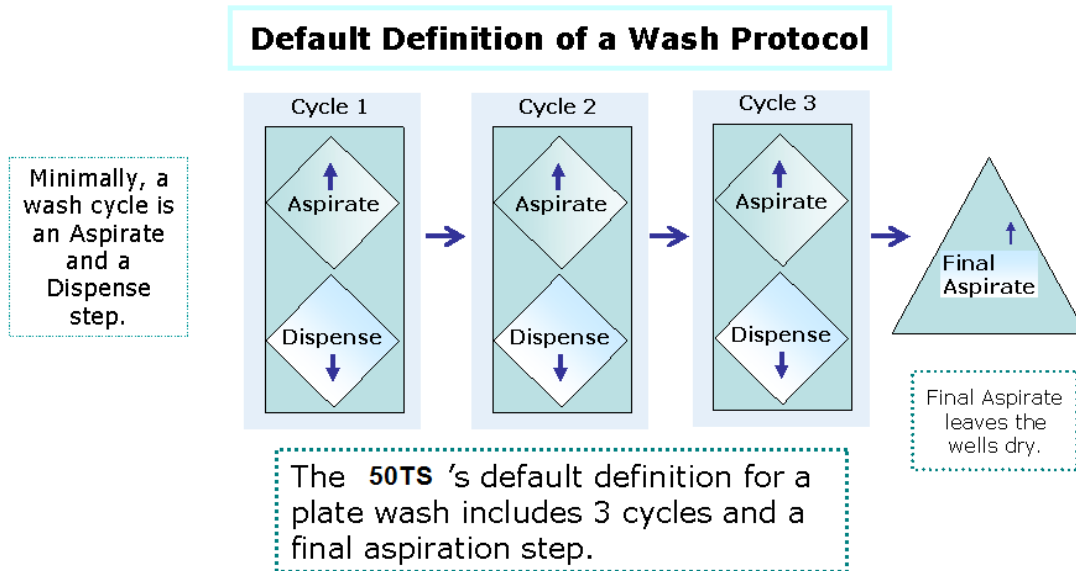

Minimally, a wash protocol has one **wash cycle**, which is an aspirate step followed by a dispense step. By default, the 50 TS's wash protocol has three wash cycles followed by a Final Aspirate step. You can customize the wash protocol:

- Change the number of cycles,
- Add pre-wash steps like bottom wash, for very vigorous washing,
- Remove the final aspirate step and raise the aspirate height to increase residuals in the wells,
- Shake the plate to mix the contents,
- Add a Soak or delay to incubate the contents at room temperature,
- Etc.

See [Run a Predefined Protocol](#) on page 45.

See [Create a Protocol](#) on page 50.

See [Vacuum Filtration for Filter Plate Assays](#) on page 60.

Optimize Performance

Important: Always fully prime the washer before running a wash or dispense program. Do not rely on **AutoPrime** to pre-prime the tubing for a protocol. AutoPrime is designed for maintenance purposes to keep the tubing in a wetted state between runs. Enable "Prime before Washing" when creating a protocol and when using the **Quick** menu, prime the tubing before running a basic wash.

Always prime the washer with dispense fluid before a run and when finished with the washer. Flush the tubing by running a prime or maintenance program. Find guidelines in the Maintenance chapter.

Vacuum Inline Filter: Installing the hydrophobic inline vacuum filter before using the 50 TS is strongly recommended. See [Connect the Fluid Supply and Waste System on page 19](#).

Before Running the Washer

- Fill the wash/rinse bottles with sufficient fluid. Make sure the supply tube is in the liquid.
- Empty the waste bottle and firmly seat the waste bottle's stopper. To prevent fluid from backing up into the vacuum pump, never allow the waste bottle to become more than three-quarters full. Alternatively, install the Liquid Level Alert.
- Check the external tubing connections for kinks and clogs.
- Make sure the bottles, solutions, and tubing are clean and do not contain particles or mold.
- To avoid creating air bubbles every time the supply bottle is filled, make a mark halfway down the bottle and refill when the fluid level drops to that point. Unscrew the cap and let it hang over the side just enough to avoid emptying the inside tube and enough to refill the bottle.
- Enable AutoPrime to keep the tubing wet during idle periods.
- Always use the correct microplate/microstrip types for the manifold:
 - 8, 8s, , 2x8 Well manifold: 96-well plates, 8-well strips.
 - 12 Well manifold: 96-well plates, 12-well strips.
 - 8,16 Well manifold: 96- or 384-well plates, 8-well strips.
 - 4 Well manifold: 24-well plates.
 - Vacuum filtration is performed only on full plates. Microstrips are not supported.
- Always put microstrips in the holder before loading them onto the carrier.
- Position microplates or strip holders with well A1 closest to the rear of the washer.

- Vacuum filtration models: make sure there is sufficient flex room for the tubing connected to the vacuum filtration carrier during operation.

Keep the Washer and Supplies Clean

Perform daily, overnight, and periodic maintenance as described in the **Maintenance Chapter** including:

- Cleaning the manifold tubes and chambers.
- Cleaning the plate carrier.
- Cleaning the supply, rinse, and waste bottles.
- Rinsing and checking the tubing.

Protocol Parameters and Instrument Settings

- Be sure to enter the correct 'First Strip' and 'Number of Strips' values at run-time.
- Washers with Buffer Switching ("V" version washers): Specify the correct reagent bottle (A, B, or C).
- Make sure the Dispense (overflow) Height (Z-axis position) in the wash protocol is low enough to remove (aspirate) excess fluid during the dispense step.
- If you use more than one manifold, make sure the instrument's setting matches the installed manifold and plate carrier.

Run a Predefined Protocol

BioTek ships the 50 TS with several predefined protocols onboard. See [Predefined Onboard Protocols Listing on the next page](#).

Certain prompts are displayed when a protocol is selected for run. Obey the prompts by making selections and completing required tasks.

Two options:

1. At the **Main Menu**, touch the protocol you want to run, or navigate to the desired protocol using the **Next** and **Prev**(previous) buttons.
2. Select **Maintenance** at the **Main Menu** to run a maintenance or instrument qualification (QC) protocol.

Running a Protocol

When you run a protocol on the 50 TS the following prompt may appear, depending on the type of protocol.

Options	Actions
First Strip	Specify the number of the first strip to be washed.
Number of Strips	Specify the number of microwell strips (microplate rows or columns) to be processed: <ul style="list-style-type: none"> • 1 to 12 for the 8- or 8s Well manifold • 1 to 8 for the 12 Well manifold • 1 to 24 for the 8,16 Well manifold • 1 to 6 for the 4 Well manifold • An even number between 1 to 12 for the 2x8 Well manifold

Predefined Onboard Protocols Listing

BioTek installs these predefined protocols onboard compatible 50 TS models. Run predefined protocols from the Main Menu (Home). Protocol settings have been optimized based on experience in our applications lab.

Sample Wash Protocols for all 50 TS Models with 8, 8s, and 12 Well Manifolds:

Protocol Name	COSTAR_FLAT	COSTAR_ROUND	NUNC_FLAT	NUNC_ROUND
Plate Type	96	96	96	96
Number of Cycles	3	3	3	3
Wash Format	Plate	Plate	Plate	Plate
Soak After Dispense	No	No	No	No
Shake After Soak	No	No	No	No
Prime After Soak	No	No	No	No
Dispense Volume	300	300	300	300
Dispense Flow Rate	5	5	5	5
Dispense Height: Z Offset	116	116	116	116
Dispense Position: Y Offset	0	0	0	0
Bottom Wash First	No	No	No	No
Prime Before Start	Yes	Yes	Yes	Yes
Prime Volume	5	5	5	5
Prime Flow Rate	5	5	5	5

Protocol Name	COSTAR_FLAT	COSTAR_ROUND	NUNC_FLAT	NUNC_ROUND
Aspirate Height: Z Offset	28	30	25	33
Aspirate Position: Y Offset	-20	12	-20	12
Aspirate Rate	5	5	5	5
Aspirate Delay	0	0	0	0
Crosswise Aspiration	No	No	No	No
Final Aspirate	Yes	Yes	Yes	Yes
Final Aspirate Delay	0	0	0	0

Sample Wash Protocols for all 50 TS Models with 8,16 Well Manifolds:

Protocol Name	COSTAR_FLT16_96	COSTAR_FLT16_384	NUNC_FLT16_96	NUNC_FLT16_384
Plate Type	96	384	96	384
Number of Cycles	3	3	3	3
Wash Format	Plate	Plate	Plate	Plate
Soak After Dispense	No	No	No	No
Shake After Soak	No	No	No	No
Prime After Soak	No	No	No	No
Dispense Volume	300	100	300	100
Dispense Flow Rate	5	5	5	5
Dispense Height	120	120	120	120
Horizontal Dispense Position	0	0	0	0
Bottom Wash First	No	No	No	No
Prime Before Start	Yes	Yes	Yes	Yes
Prime Volume	5	5	5	5
Prime Flow Rate	5	5	5	5
Aspirate Height	26	22	26	22
Horizontal Aspirate Position	0	0	0	0
Aspirate Rate	5	5	5	5
Aspirate Delay	0	0	0	0
Crosswise Aspiration	No	No	No	No

Protocol Name	COSTAR_ FLT16_96	COSTAR_ FLT16_384	NUNC_ FLT16_96	NUNC_ FLT16_384
Final Aspirate	Yes	Yes	Yes	Yes
Final Aspirate Delay	0	0	0	0

Biometric Separation Sample Protocols for 50TS: 8M, 8MV, 8MF Models

Protocol Name	LUM_MAG_FLAT_96	LUM_MAG_RND_96
Plate Type	96	96
	Shake 1 sec, 1 (15Hz), soak 1 min	
Number of Cycles	2	2
Wash Format	Plate	Plate
Soak After Dispense	Yes, 30 sec	Yes, 30 sec
Shake After Soak	No	No
Prime After Soak	No	No
Dispense Volume	200	100
Dispense Flow Rate	3	5
Dispense Height	120	128
Horizontal Dispense Position	0	0
Bottom Wash First	No	No
Prime Before Start	Yes	Yes
Prime Volume	5	5
Prime Flow Rate	5	5
Aspirate Height	29	58
Horizontal Aspirate Position	0	24
Aspirate Rate	7	1
Aspirate Delay	0	0
Crosswise Aspiration	No	No
Final Aspirate	Yes	Yes
Final Aspirate Height	38	58
Final Horizontal Aspirate Position	0	24
Final Aspirate Rate	7	1

Protocol Name	LUM_MAG_FLAT_96	LUM_MAG_RND_96
Final Aspirate Delay	0	0

Qualification Protocols

Select the **Maintenance** menu on the Home screen.

DISPENSE	µL/well	Dispense Height (Z)	Flow Rate
accuracy_qc_test	300	146	5
accur_qc_test384	100	120	6

ASPIRATE	Height (Z)	Asp Horizontal (Y)	Travel Rate
residual_qc_test	28	-20	1
resid_qc_test384	22	0	3

Vacuum Filtration	Volume: µL/well	Flow Rate
VAC30	300	6

Maintenance

Maintenance Protocols

MAINTENANCE
DAY_RINSE
DECONTAMINATION
LONG_SHUTDOWN
OVERNIGHT_LOOP
RINSE_AND_SOAK
PRIME_ALL_BUFFERS ¹

¹For "V" models with buffer switching capability.

Create a Protocol

Follow these general guidelines for creating a protocol. See [Protocol Parameters Reference Tables](#) on the facing page.

1. Select **Protocol** at the main menu.
2. Select **Create**.
3. Enter a unique name for the new protocol.
4. Select the **Plate Type** and press **Save**.
5. Press **Add** and select the type of action to perform.
6. Define the parameters for the step and add more steps, as needed.

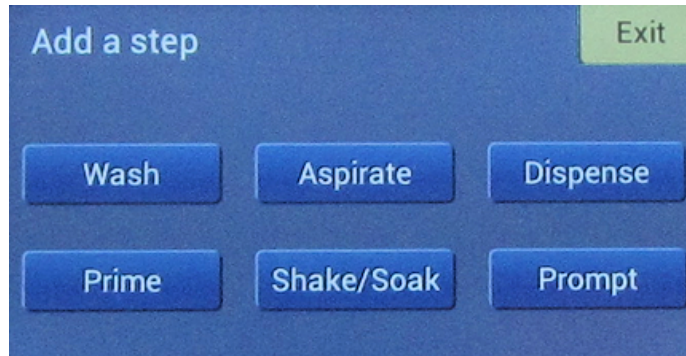

Edit To fine-tune a protocol to improve assay performance, select the protocol and press **Edit** at the Protocol Definition screen. Then, select the step and press **Edit** to modify its parameters.

Info Press **Info** to change the protocol's name or plate type.

Copy Save time by copying a similar protocol and editing its steps.



Select a step and then use the **Copy**, **Paste**, and **Cut** buttons as needed to add, remove or reposition steps. To paste a step, select the step or **<end of steps>** **below** the desired position of the copied or cut step, then press Paste.

Wash Step

Touch the **Aspirate** and/or **Dispense** boxes to modify the default parameters for these parts of the wash step.

Wash options

Press **Wash options** to enable and define additional actions.

Toggle the **Yes/No** buttons to enable or disable an option.

Press **Edit** to define the parameters of the option.

See [Wash Protocol Parameters](#) on the next page for descriptions.

Advanced options

In an aspirate or dispense step, press **Advanced options** to better position the manifold tubes in the Z-axis (height) and Y-axis (horizontal position). Some experimentation may be needed to find optimal settings.

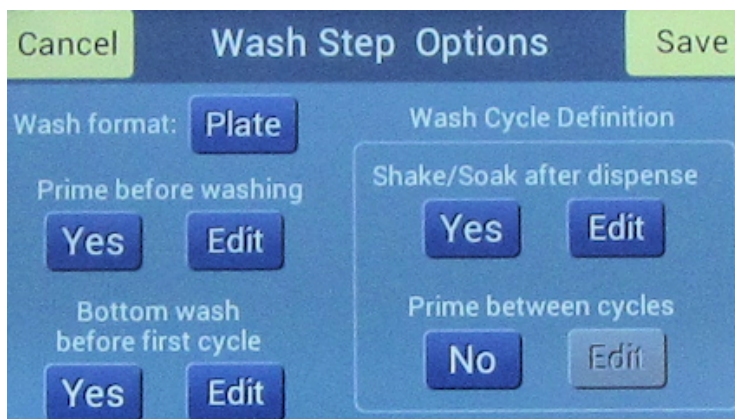
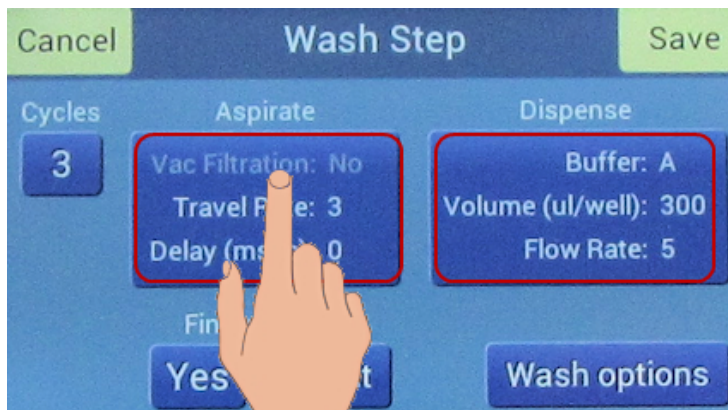

Best practice: In a wash step, set a dispense height that positions the aspirate tubes at the top of wells to draw off any overflow.

Protocol Parameters Reference Tables

Review these tables for details about the available protocol parameters:

- [Wash Protocol Parameters on the next page](#)
- [Dispense Protocol Parameters on page 53](#)
- [Aspiration Protocol Parameters on page 55](#)
- [Soak and Shake Protocol Parameters on page 57](#)

Wash Protocol Parameters

Method	Action/Description	Default
Number of Cycles	One wash cycle includes, at minimum, one aspirate and dispense sequence. Other options added to the protocol, like shake and soak, are also performed in each cycle. Pre-prime, when selected, is performed one time before the wash cycles. Bottom Wash adds another cycle to the protocol when enabled. Final Aspirate is done once after all cycles are completed.	3
Wash Format: Plate or Strip.	Plate format performs each cycle on the entire plate (or all of the strips) before it starts the next cycle. Strip format performs all cycles on one strip before it moves to the next strip. You must specify the number of strips to wash at runtime.	Plate
Soak/ Shake	Enable soaking and/or shaking to steep and/or mix the wash buffer in the wells after the dispense step; then specify a duration.	No
Soak Duration	The amount of time to delay processing or to steep fluid in the wells before aspiration. A soak begins after the wash buffer is dispensed. In some assays it enhances washing by allowing unbound material to diffuse into the wash buffer. When washing strips in a plate format use a soak that lasts as long as it takes to process one wash cycle of all strips.	30
Shake Duration	The amount of time to agitate the plate. The duration range is from 1 second to 30 minutes.	5
Shake Intensity	Specify the intensity of microwell shaking. The options range from 1 to 5, where 1 = Least Intense, 5 = Most Intense. The washer shows the corresponding cycles/sec value for each option.	3
Prime Between Cycles?	Choose Yes to prime the dispense tubes between cycles, to correct for evaporation, for example. Generally, this is only necessary after a delay or a long soak, >10 minutes.	No

Method	Action/Description	Default
Prime Volume	Specify the volume in milliliters. The range is from 1 to 200 mL.	5
Prime Flow Rate	Specify the rate at which to pump the priming fluid into the dispense tubes. The flow rate options range from 1 to 9 (except 1-7 for the 12-channel manifold, and 1-5 for the 4-, and 2x8-well manifolds), where 1 = Slowest, 9 = Fastest. See Dispense and Prime Flow Rates on page 55 .	5

Dispense Protocol Parameters

Options	Actions	Default
Dispense Volume	The volume to dispense per well per wash cycle. The volume range is 50 to 3000 μ L/well for 96-well plates. When dispensing to 384-well plates, the range is 25-3000 μ L/well.	300
Dispense Flow Rate	Flow rates range from 1 to 9 (except 1-7 for the 12-channel manifold, and 1-5 for the 4 and 2x8 Well manifolds). 1 = Slowest, 9 = Fastest. See Dispense and Prime Flow Rates on page 55 . The flow rate must be valid for the manifold and dispense volume. For Troubleshooting: See Dispense Volume Invalid for Manifold Type (0F00 Error) on page 153 .	5
Dispense Height (Z-axis)	The height between the bottom of the aspirate tubes and the carrier surface when dispensing. The dispense tubes are shorter than the aspirate tubes. The Dispense Height range is from 12 to 180 steps. The washer displays the corresponding millimeters. 12 is closest to the carrier surface, 180 is furthest from this surface. Overflow Position: It is considered good practice to set a dispense height that positions the aspirate tubes at the top of wells to draw off any overflow.	120

Options	Actions	Default
Horizontal Position (Y-axis)	<p>The position of the manifold tubes in relation to the center of the microwells.</p> <p>The Horizontal Disp Pos range is from -24 to 24 for the 8- and 12-channel manifolds and the 2x8 manifold; -88 to 24 for the 8s-manifold; -24 to 15 for the 16-channel when addressing 96-well plates and -22 to 10 for 384-well plates; the 4 (24-well plate) manifold range is -180-60. The washer displays the corresponding millimeters.</p> <p>A negative offset moves the dispense tubes back, away from the front of the washer. A positive offset moves the dispense tubes toward the front of the washer. A setting of 0 indicates no offset.</p>	0
Bottom Wash First? Bottom washing adds an initial aspirate-dispense sequence to the specified number of wash cycles when extra vigorous washing is required.	<p>Specify bottom wash parameters to position the manifold deep in the well. For example, set the Bottom Disp Height to between 30-50 steps. Reagent is dispensed and aspirated simultaneously at this height to create cleaning turbulence. The plate is aspirated again and the process ends with a final dispense to fill the wells.</p> <p>In Vacuum Filtration models, when the aspirate step is defined as VAC, this aspiration method is used for the Bottom Wash, as well.</p>	No
Bottom Disp Volume	The volume range is 50 to 3000 $\mu\text{L}/\text{well}$. 150-400 $\mu\text{L}/\text{well}$ is typical.	300
Bottom Flow Rate	Valid options: 1 to 9 (except 1-7 for the 12-channel manifold, and 1-5 for the 4 and 2x8 Well manifolds).	5
Bottom Disp Height	Valid range from 12 to 180 steps.	60
Bottom Horiz Pos	Valid range is same as regular wash step (see above).	0
<ul style="list-style-type: none"> Negative values: To enter a negative value, toggle the +/- button. 		

- Do not confuse Bottom Wash options with vacuum filtration, which evacuates filter or membrane plates from below. Bottom wash is for extra vigorous

washing to reduce background or noise when reading the plate. Review [Vacuum Filtration for Filter Plate Assays on page 60](#).

Dispense and Prime Flow Rates

Flow rates: **uL/well/second** for each manifold type.

Flow Rate	Manifold Type				
	8/8s	12	8,16	4	2x8
1	150	150	225	300	150
2	200	200	250	400	200
3	300	300	300	600	300
4	450	450	325	900	450
5	500	500	350	1000	500
6	600	600	375	--	--
7	650	650	400	--	--
8	800	--	450	--	--
9	1000	--	500	--	--

Aspiration Protocol Parameters

Options	Actions	Default
Aspirate Type	Standard aspiration using the manifold or Vacuum Filtration for 8F and 8MF models using the vacuum filtration carrier.	
Filtration Time	When Aspirate Type is set to Vacuum Filtration. The range is 1-180 seconds. Experimentation is recommended to determine the optimal setting for your assays.	30
Aspirate Height (Z-axis)	The height between the bottom of the aspirate tubes and the carrier surface when aspirating the microwells. The aspirate tubes are longer than the dispense tubes.	24

Options	Actions	Default
	<p>Ranges from 12 to 180 steps. The washer shows the corresponding millimeters. 12 is the closest to the carrier, 180 is the furthest.</p>	
<p>Y-axis Position (Horizontal)</p>	<p>The position of the manifold tubes in relation to the center of the microwells.</p> <p>The Y-axis range is from -24 to 24 for the 8- and 12-channel manifolds and the 2x8 manifold; -88 to 24 for the 8s-manifold; -24 to 15 for the 16-channel when addressing 96-well plates and -22 to 10 for 384-well plates; the 4 (24-well plate) manifold range is -180-60. The washer displays the corresponding millimeters.</p> <p>A negative offset moves the aspirate tubes back, away from the front of the washer. A positive offset moves the tubes toward the front of the washer. A setting of 0 indicates no offset.</p> <p>Note: For flat-bottom plates, position the aspirate tubes near the edge of the well for minimal residual volume.</p>	0
<p>Travel Rate</p>	<p>The rate at which the wash manifold travels down into the wells. Options range from 1 to 7, where 1 is slowest and 7 is fastest. The washer shows the corresponding mm/sec value for each option.</p>	3
<p>Aspirate Delay</p>	<p>The time delay starting when the tube is at its aspiration height and ending when it next moves. The valid range is 0 to 5000 milliseconds.</p> <p>The delay applies to the normal (initial) aspiration when Secondary (aka Crosswise) Aspirate is disabled. If Secondary Aspiration is enabled, the delay applies to the second, not the initial, aspiration.</p>	0
<p>Secondary aspirate (Crosswise)</p>	<p>A secondary or crosswise aspiration is a two-step aspiration. The wells are first aspirated at the initial aspirate position. The aspirate tubes rise a fixed number of steps and then do a second aspiration at the secondary position. It is useful for eliminating residual sample or reagent from the wall perimeter.</p>	No
<p>Final Aspirate</p>	<p>In a wash step, select YES to designate a final aspiration,</p>	Yes

Options	Actions	Default
	leaving the wells empty.	
Final Aspirate Delay	Same as Aspiration Delay (see above) applied to the final aspiration.	0
<ul style="list-style-type: none"> Negative values: To enter a negative value, toggle the +/- button. 		

Soak and Shake Protocol Parameters

Add a Shake/Soak step to the protocol to mix plate contents.

Options	Actions
Shake	To mix the wells' content during the procedure. Before shaking begins, the manifold rises and the carrier returns home so the tubes are above the priming trough and cannot contaminate the plate/strips.
Shake Duration	Defines how long to shake the plate/strips. The duration range is from 1 second to 30 minutes.
Shake Intensity	Specify the shake intensity from 1 to 5, where 1 is least intense, 5 is most intense. The washer shows the corresponding cycles/sec or Hertz (Hz) value for each option.
Soak Duration	Soak Duration is the time to allow the wash buffer to remain in the wells before aspiration. The range is from 1 second to 10 minutes. Note: When washing strips in a plate format define a soak that lasts as long as it takes to process one wash cycle of all strips.

Special Applications

In addition to performing standard ELISA assays, some models can perform more specialized applications:

- See [Biomagnetic Separation Assays](#) below
- See [Vacuum Filtration for Filter Plate Assays](#) on page 60

Biomagnetic Separation Assays

50 TS Biomagnetic Separation models (8M, 8MV and 8MF) ship with a microplate carrier that supports placement of a magnet under the microplate. The design induces magnetic beads to settle and remain fixed throughout a wash protocol's aspirate and dispense cycles.



Persons with pacemakers/implants should avoid direct contact. Keep all magnetic media, watches, and sensitive electronic devices away from the LifeSep units. Credit cards, tapes, and disks can be erased in the presence of a magnetic field. Bodily harm [pinching of hands and skin] can result if magnets are not handled correctly. Maintain distance between two or more LifeSep units.

The 50 TS supports standard microplates and these magnets available for purchase from BioTek:

Plate Type	Magnet	PN
96-well	96 Flat Magnet	7103016
	96 Ring Magnet	7102216

You can use a different magnet if it fits in the carrier and accommodates your plates. Contact BioTek TAC or visit the Customer Resource Center at www.biotek.com to obtain a drawing of the carrier with its dimensions.

Handling and Cleaning the Magnets

For best magnet strength and bead retention, the bottom of the microplate must be as close to the magnet as possible. We recommend using flat-bottom plates with minimal support “webbing” between the sides of the outer wells and the plate skirts.

Handle the magnets with care. Avoid direct contact with the magnet material. Keep loose ferrous material away and do not attempt to disassemble. Store the magnet in a cool, dry environment and clean it with a damp cloth and mild detergent when exposed to harsh solvents. **Do not autoclave.**

Installing and Removing the Magnet

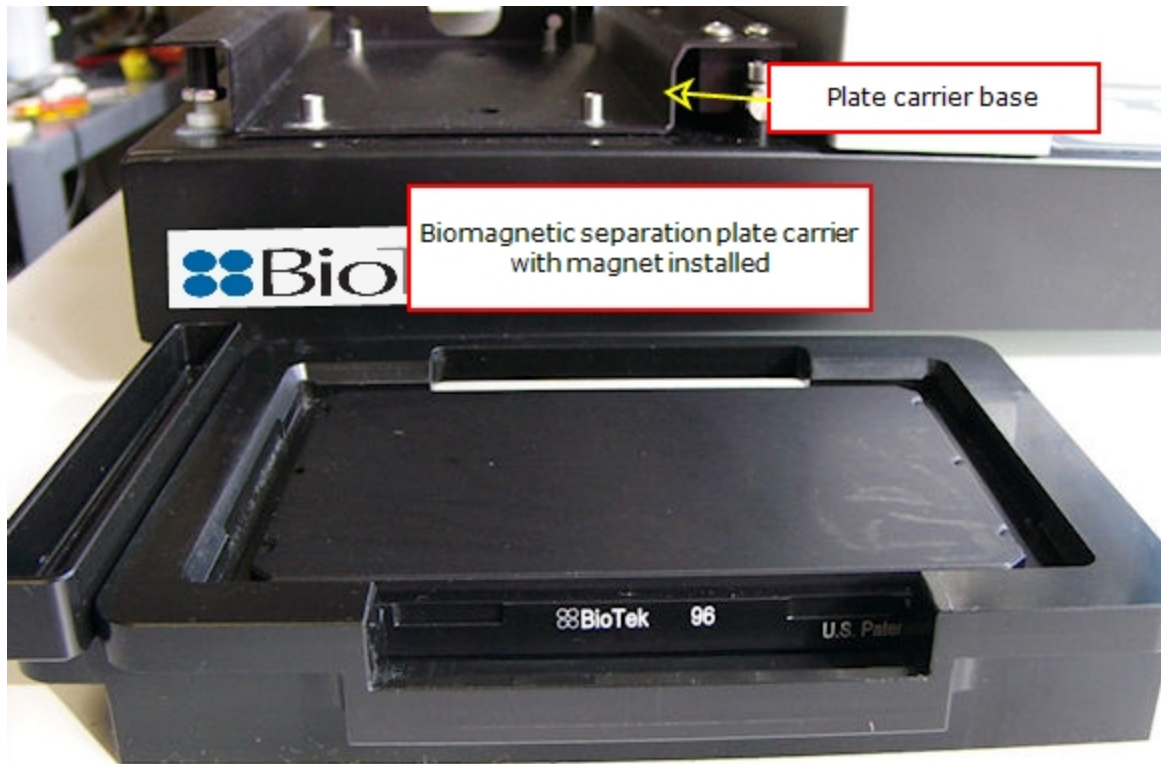

It is easiest and safest to install and remove the magnet when the carrier is removed from the instrument.

1. First remove the biomagnetic separation plate carrier from the carrier base (if necessary).
2. To install the **magnet** in the proper orientation:
 - Flat magnet: place in the plate carrier so that the text on the side of the magnet is readable.
 - Ring magnet: place in the plate carrier with the small round magnets visible, facing upwards.
 - Make sure the magnet is level.
3. Reinsert the biomagnetic separation plate carrier with the magnet installed into the plate carrier base.

To remove the magnet, reverse these steps, first removing the plate carrier from the base, and then, removing the magnet from the carrier.

Optimize Biomagnetic Separation protocols

- Predefined protocols that have been optimized to run Luminex® assays are provided onboard: **LUM_MAG_FLAT_96** and **LUM_MAG_RND_96** for flat-bottom and round-bottom 96-well microplates. Other sample protocols, e.g., **COSTAR_ROUND**, **NUNC_FLAT**, are designed for use **without** the magnet. Modify a copy of these protocols for use with the magnet, if desired.
- When creating protocols for use with a magnet, increase the **Dispense Height** and **Aspirate Height**. The default values may position the manifold tubes too low when the magnet is installed. Likewise, if the protocol includes bottom wash and/or crosswise aspiration, adjust the **Bottom Dispense Height** and/or **Secondary Height** parameters.
- Increase the **Plate Clear Height** before running biomagnetic separation assays to accommodate the increased height of the plate when a magnet is installed: **Instrument>Plate Clearance**.

■ BioTek cannot provide specific suggestions for increasing the height values without knowing the specific plate type in use. To help you determine how much to increase the height, each step is approximately .127 mm or .005". If possible, measure the height of the plate with and without the magnet underneath it, and increase the height values accordingly. The instrument displays the height value in millimeters (mm). For example, a Costar 96-well clear plate is about 1.27 mm (.050") or 10 steps higher with the magnet in place.

- Before running assays on the washer, we recommend testing new protocols using deionized water plus .05% or .1% Tween® 20 with the desired microplate and a magnet installed.

Vacuum Filtration for Filter Plate Assays

50 TS Vacuum Filtration models (8F and 8MF) can process most standard-size filter-bottom microplates. To prepare the instrument, install the special plate carrier and connect its tubing to the vacuum pump.

Install the Plate Carrier

See [Install the Microplate Carrier](#) on page 27

Load a Filter Plate

See [Vacuum Filtration Carrier- Load or Unload a Plate](#) on page 63

Recommendations for best performance:

Here are some guidelines to achieve the best performance of your filter plate assays:

- **Shake the plate to suspend the beads before aspiration.** Enable the wash cycle option to shake the plate after the dispense and before aspiration. Also consider creating a multi-step protocol that begins by shaking the plate.
- Do not use dry filter plates.
- Experiment with the **aspiration time** and **vacuum level** to determine the best combination of settings for your assay. Start with a brief time period and low vacuum to avoid lodging the beads in the filter material. Review "Controlling the Vacuum Level" below, and its effect on aspiration duration.
- **Maintain consistent vacuum** during the process with a tight seal:
 - Use new or defect-free filter plates and make sure they are seated perfectly in the carrier;
 - Make sure all tubing and bottle caps are clean, connected correctly, and leak-free.

Create a Vacuum Filtration Protocol

1. From the Main Menu (Home), select **Protocol>Create** and assign a unique name to the protocol.
2. Press **Add** to add steps to the protocol.
3. Begin with a short Shake/Soak step to suspend the beads.
4. Add a **Wash** step:



- Touch the **Aspirate** box and change **Vacuum Filtration** to **Yes** and set the **Filtration Time**.
- Set the **Final Aspirate** to match: touch **Edit** to change the settings.

■ Initially, try shorter aspiration times (e.g. 5 sec); increase the vacuum filtration time until suitable aspiration is achieved.

5. Press **Wash Options**.
6. Change the **Shake/Soak** option to Yes and touch **Edit** to shake the plate for at least 5 seconds to suspend the beads after a dispense.
7. **Save** the protocol and return Home to run it.

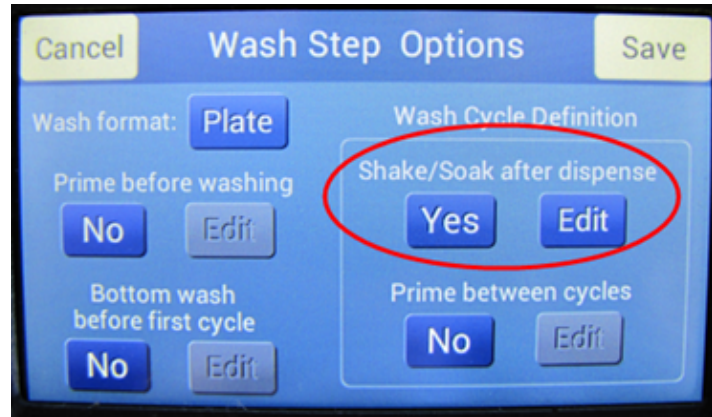

Controlling the Vacuum Level

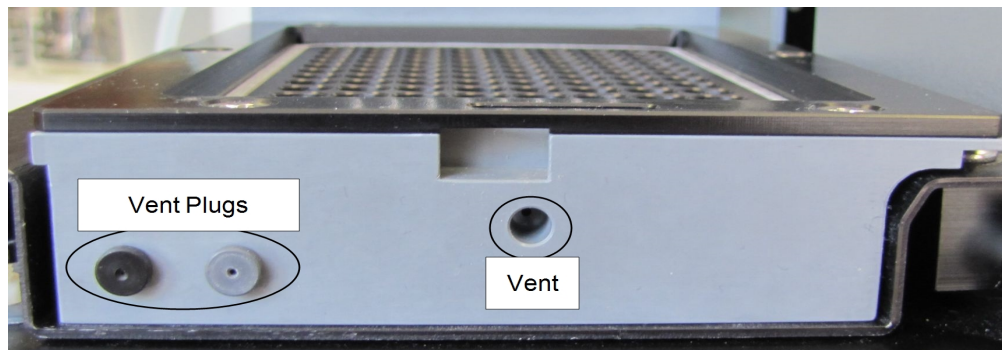

Change the vent plug to control the vacuum level

The special vacuum filtration plate carrier has a vent and ships with two vent plugs to vary the vacuum levels:

Plug	Vent Diameter	Vacuum Level	Average (mmHg)	Pressure (kPa)
No plug	0.047" (1.19 mm)	Lowest	-64	-8.51
Gray	0.032" (0.81 mm)	Medium	-116	-15.43
Black	0.020" (0.51 mm)	High	-240	-31.92

Leave the vent open for the least amount of vacuum. Insert one of the plugs to increase vacuum.

- Vacuum pressure is affected by several factors like relative humidity, barometric pressure, and mechanical tolerances.

Testing at BioTek confirmed expectations: small pore filter plates and highly viscous fluids require increased vacuum and/or longer aspiration durations to evacuate the wells.

Maintenance

The most critical factor in keeping the 50 TS in top condition is regular maintenance, which includes frequent rinsing and soaking of the tubing. Be sure to follow the guidelines provided in the Maintenance chapter.

Clean the Vacuum Filtration Plate Carrier: Use a damp (not sopping wet) cloth to wipe up any spills, especially if the fluid is prone to dry and harden quickly. If necessary, flush it out with warm water by holding it under a running faucet for a few seconds and dry it immediately and completely.

Decontamination: Run the predefined protocol for vacuum filtration, **VAC30_TEST**, with a disinfectant as the fluid supply. Conclude the process by running DI water through the system.

Vacuum Filtration Carrier- Load or Unload a Plate

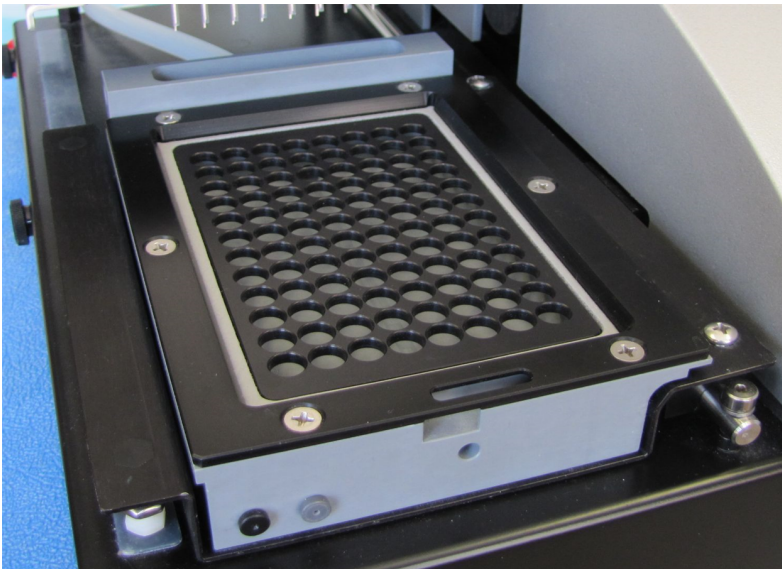

See [Install the Microplate Carrier](#) on page 27 for installation instructions.

Put the filter-bottom plate on the special carrier.

Vacuum Filtration Carrier with Plate Clamps:

Standard vacuum filtration carriers do not have a plate clamp. A kit is available to add a clamp to the carrier to achieve a tighter seal, especially with non-rigid filter plates. When the clamp is installed:

1. Release the latch at the front of the plate carrier with one hand and lift the plate clamp to open it.
2. Insert or remove the plate.

■ BioTek offers a plate clamp kit for vacuum filtration carriers: PN 4070563. The plate clamp provides a better seal with some filter plates, often improving assay performance.

System Startup

To turn on the 50 TS, press the on/off switch on the right side of the base. The 50 TS performs a self-test each time it is started.

If the self-test fails, the washer will beep and display an error code. Note the error code and then press **OK** to stop the beeping. Look up the code in [Error Codes on page 134](#).

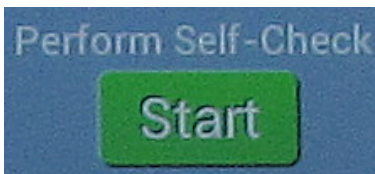

Select **Instrument>Options** to rerun the self-check to clear error messages or to check for errors.

How to copy a protocol

You can save time creating protocols by copying a protocol that shares some of the same protocol parameters and then editing the copy to meet your needs.

1. Select **Protocol** at the main menu.
2. Touch the protocol you want to copy, and select **Copy**.
3. Name the new protocol, choose the plate type and press **Save**.
4. Select **Edit** to "Add" or "Edit" steps or otherwise change the protocol. Press **Exit** when finished.



When editing a protocol, press **Info** to change the protocol's **name** or **plate type**.

How to delete a protocol

Delete a protocol to remove it from the Home screen (Main Menu), and to free-up space onboard for more protocols.

1. Select **Protocol** at the Home screen.
2. Highlight the protocol you want to remove and press **Delete**.
3. Confirm your intention to remove the protocol at the prompt.

Instrument Configuration - Setup Controls

The **Instrument** menu leads to controls for:

- [Instrument Setup below](#)
- [AutoPrime](#)

Instrument Settings

Manifold Selection

Your 50 TS was initially configured for and shipped with a wash manifold. The washer's manifold setting must match the type of manifold installed on the instrument. If you change the hardware, you must also change the setting.

Manifold Type	PN	Plate Type	Onboard
4 Well	1550504	24-well	4
8 Well	4070512	96-well	8
8 Well Short Dispense Tube	4070519	96-well	8s
2 X 8 Well	1550501	96-well	2x8
12 Well	4070513	96-well	12
8, 16 Well	4070527	96 & 384-well	8,16

Plate Carrier Selection

The type of plate carrier installed on the instrument must match this setting to ensure expected performance.

- Standard
- **384 Well**: compatible with the 8,16 Well manifold.
- **Magnetic Separation**: special plate carrier for holding a magnet.
- **Vacuum Filtration**: special carrier for performing vacuum aspiration or filtration assays. This setting must be selected to run a vacuum filtration protocol.

Plate Clearance Height

Plate Clearance Height specifies how high to raise the manifold tubes to prevent crashes when the plate carrier moves. The clearance height range is 12 (3.048 mm) to 195 (24.77 mm), with a default value of 146 (18.55 mm). Use this option with 8M, 8MV and 8MF models to increase the plate clearance height for magnetic bead assays.

Note: When using the 4 Well Manifold the Plate Clearance setting is ignored and the manifold is raised to its highest position during travel.

To change the plate clearance height, select: **Instrument>Config>Plate Clearance**.

Liquid Level Sensor

50 TS washers support Liquid Level Alert: with a level sensing device inside the supply and waste bottles. The sensor is activated when a supply bottle's fluid level drops to approximately 400-450 mL and the waste bottle's fluid level rises to approximately 1400-1450 mL.

The washer checks the status of the sensor at the start and end of all runs. Error codes 2800 or 2900 display when a sensor is activated. If this happens, press OK, check the state of the supply and waste bottles. You can fill or empty the bottles, as needed, and then continue the run, if desired.

Sensor detection is *disabled* on the washer by default. To change the setting, select: **Instrument>Options** and set **Liquid Level Sensing** to **Enabled**.

Protocol Display Order

Select **Instrument>Options** to change the sort order of protocols on the Main Menu.

- **Last run first:** reorders the list beginning with the protocol that was last run.
- **Alphabetically:** orders this list by protocol name.

AutoPrime

AutoPrime keeps the tubing wet to prevent clogging during idle periods. It is highly recommended for daily and overnight maintenance.

AutoPrime automatically primes the washer when it has been idle for a user-specified amount of time. AutoPrime is recommended when the washer is used intermittently throughout the day, to keep the manifold tubes in a wetted

condition between runs. It is especially useful when using wash buffers that are prone to harden or crystallize. See [AutoPrime](#) on page 40.

Maintenance

Properly maintaining the washer is the key to reliable performance.

About Maintaining the Washer	70
Warnings & Precautions	71
Recommended Maintenance Schedule	72
Prime Programs	73
Daily Maintenance: Rinse/Soak the Fluid Path	77
Maintenance Programs	77
DAY_RINSE	77
AutoPrime	78
Enable AutoPrime	78
Overnight/Multi-Day Maintenance	78
Removing Protein Residuals and Fungi Growth	79
Clean Components	80
Clean the Bottles	81
Clean the Touchscreen	81
Clean the Exterior Surfaces	81
Clean the Carrier	82
Clean the Mist Shield	83
Clean the Manifold	83
Tools for cleaning dispense and aspirate tubes	83
Clean the Aspirate and Dispense Tubes	84
Decontaminate the Washer	87
Decontamination Tools and Supplies	88
Decontaminate the External Surfaces and Components	89
Decontamination Procedure for Tubing and Manifold	90
Decontaminate the Vacuum Filtration Carrier	90
Alternate Decontamination Procedure for Tubing and Manifold	91
Prepare for Storage or Shipment	91
Storing the Washer	92
Replace Components	93
Replacement (Spare) Parts Listing	93
Replace (or Clean) the Check Valves	94
Vacuum Filtration Carrier: Replace the Gasket	94
Maintenance/Performance Log	96

About Maintaining the Washer

This section describes a set of procedures to perform regularly to maintain equipment in top condition. For example, during normal operation, salt crystals may build up and clog the valves and tubes. Adherence to the [Recommended Maintenance Schedule](#) will reduce this problem, extend the life of the washer, and enable the washer to meet performance specifications.

The schedule summarizes the recommended maintenance tasks, and indicates approximately how often to perform each task. Beyond that, it is difficult for BioTek to recommend a fixed frequency for each task. The risk and performance factors of your assays must determine the frequency with which to conduct these tasks. Therefore, BioTek recommends that you develop a maintenance schedule for your washer based on the characteristics of the fluids used and the washer's activity level.

Some questions you should consider are:

- **Are the fluids you're using prone to dry and harden quickly?** If yes, the dispense and aspirate tubes can clog quickly, and therefore they must be rinsed frequently and cleaned regularly.
- **Is the washer in use continuously, or does it sit idle for several hours or days at a time?** If the washer will be sitting idle, the tubes should be soaked to keep them in a "wetted" state. Perform the rinsing procedure (or [Enable AutoPrime](#)) when the washer is idle for more than 3 hours.
- **Is a solution containing surfactant used throughout the day?** The nature of the wash solutions affects the rinsing frequency. If the solution does not contain surfactant, consider rinsing (or running AutoPrime) at least once an hour.

Consider your wash buffer's properties and always use the same fluid or a compatible fluid to keep the tubing from clogging up. For example, use DI water to flush PBS from the system, and an enzyme-active detergent, like [Terg-A-Zyme](#)[®], to remove proteins. Never use alcohol to flush out BSA.

■ **Important:** The risk and performance factors associated with your assays may require performing some or all of the procedures more frequently than recommended in the schedule.

Warnings & Precautions

Please read the following before performing maintenance procedures:



Warning! Internal Voltage. Turn off and unplug the instrument for all maintenance operations.

Warning! Wear protective gloves when handling contaminated instruments. Gloved hands should be considered contaminated at all times; keep gloved hands away from eyes, mouth, nose, and ears.

Warning! Mucous membranes are considered prime entry routes for infectious agents. Wear eye protection and a surgical mask when there is a possibility of aerosol contamination. Intact skin is generally considered an effective barrier against infectious organisms; however, small abrasions and cuts may not always be visible. Wear protective gloves when handling contaminated instruments.

Caution: Chemical Compatibility with Washers. Some chemicals may cause irreparable damage to washers. The following chemicals have been deemed safe for use in washers: buffer solutions (such as PBS), saline, surfactants, deionized water, 70% ethyl, isopropyl, or methyl alcohol, 40% formaldehyde, and 20% sodium hydroxide. Never use acetic acid, DMSO, or organic solvents. Other chemicals may cause severe damage to the instrument. Contact BioTek prior to using any other chemicals.

Caution: Sodium Hypochlorite. Do not expose any part of the instrument to the recommended diluted sodium hypochlorite solution (bleach) for more than 20 minutes. Prolonged contact may damage the instrument surfaces. Be certain to rinse and thoroughly wipe all surfaces.



Important! Do not immerse the instrument, spray it with liquid, or use a "wet" cloth on it. Do not allow water or other cleaning solution to run into the interior of the instrument. If this happens, contact BioTek's Technical Assistance Center.

Recommended Maintenance Schedule

TASK	Frequency		Long-Term Storage
	Daily	Monthly	
Rinse/Soak the Fluid Path			
Daily maintenance: DAY_RINSE	✓		
Daily/Overnight maintenance: AutoPrime	✓		
Overnight maintenance: OVERNIGHT_LOOP	✓		
As needed: RINSE_AND_SOAK	✓		
As needed:Protein-residual removal	✓		
Clean Components			
Clean bottles		✓	✓
Check/empty waste bottle	✓		✓
Clean touchscreen	✓		✓
Clean manifold		✓	✓
Clean mist shield		✓	
Clean aspirate and dispense tubes		✓	✓
Clean microplate carrier		✓	✓
Clean (or replace) check valves		✓	✓
Decontaminate the Washer			
Decontaminate the external surfaces		✓	✓
Run DECONTAMINATION		✓	✓
Prepare the Washer for Storage or Shipment			
Run LONG_SHUTDOWN			✓
Replace Components			
Check valves	<i>As Needed</i>		
Vacuum filtration carrier gasket	" "		

Prime Programs

Maintenance

Most of the onboard **Maintenance** programs are predefined prime protocols. (Instrument qualification protocols are also run from the Maintenance menu.)

Maintenance Program:	DAY_RINSE
Prime Volume:	60 mL
Flow Rate:	5
Soak After Prime?	No

Maintenance Program:	RINSE_AND_SOAK
Prime Volume:	60 mL
Flow Rate:	5
Soak After Prime?	Yes
Soak Duration:	5 minutes

Maintenance Program:	OVERNIGHT_LOOP
Prime Volume:	40 mL
Flow Rate:	5
Soak After Prime?	Yes
Soak Duration:	4 hours

To keep the washer's dispense tubes wet overnight or over a weekend, the "Overnight_Loop" protocol repeats the prime and 4-hour soak twelve times (for approx 48 hours). Fill the supply bottle and empty the waste bottle before starting the program.

Maintenance Program:	PRIME_ALL_BUFFERS
Buffer C:	40 mL
Buffer B:	40 mL

Maintenance Program:	PRIME_ALL_BUFFERS
Buffer A:	60 mL
Flow Rate:	5
Soak After Prime?	No

Maintenance Program:	DECONTAMINATION	
Step:	Without buffer switching	With buffer switching
Prompt:	"Connect disinfectant bottle"	"Conn disinfect bottles to A&B"
Prime:	60 mL, rate 5, soak 20 mins	Buffer A: 40 mL, rate 5, no soak
Prime:		Buffer B: 40 mL, rate 5, no soak
Prompt:	"Connect rinse bottle"	"Disinfect to C; rinse to A&B"
Prime:		Buffer C: 60 mL, rate 5, soak 20 mins
Prime:	60 mL, rate 5, soak 2 mins	Buffer A: 60 mL, rate 5, no soak
Prime:		Buffer B: 60 mL, rate 5, no soak
Prompt:		"Connect rinse bottle to C"
Prime:		Buffer C: 60 mL, rate 5, soak 2 mins

Maintenance Program:	LONG_SHUTDOWN	
Step:	Without buffer switching	With buffer switching
Prompt:	"Connect disinfectant bottle"	"Conn disinfect bottles to A&B"
Prime:	60 mL, rate 5, soak 20 mins	Buffer A: 40 mL, rate 5, no soak

Maintenance Program:	LONG_SHUTDOWN	
Step:	Without buffer switching	With buffer switching
Prime:		Buffer B: 40 mL, rate 5, no soak
Prompt:	"Connect rinse bottle"	"Disinfect to C; rinse to A&B"
Prime:	60 mL, rate 5, soak 2 mins	Buffer C: 60 mL, rate 5, soak 20 mins
Prime:		Buffer A: 60 mL, rate 5, no soak
Prime:		Buffer B: 60 mL, rate 5, no soak
Prompt:	"Disconnect bottle"	"Connect rinse bottle to C"
Prime:	60 mL, rate 5, no soak	Buffer C: 60 mL, rate 5, soak 2 mins
Prompt:		"Disconnect all bottles"
Prime:		Buffer A: 60 mL, rate 5, no soak
Prime:		Buffer B: 60 mL, rate 5, no soak
Prime:		Buffer C: 200 mL, rate 5, soak 2 mins

Dead Volume

Consider these approximate dead volumes when defining priming values to adequately prime the tubing before running a wash or dispense protocol.

BioTek recommends priming with two or three times the dead volume for a dry instrument and when changing fluids. For example: dead volume (20 mL washer + 5 mL manifold) x 2 = 50 mL prime volume.

Washer/Manifold	Dead Volume
50 TS without Buffer Switching	20 mL
50 TS with Buffer Switching ("V" models) with full 28" supply tubing	35 mL
50 TS "V" model with supply tubing cut to 8"	25 mL

Washer/Manifold	Dead Volume
All manifolds except the 2x8 Well manifold	5 mL
2x8 Well manifold	10 mL

Daily Maintenance: Rinse/Soak the Fluid Path

Maintenance Programs

Run these predefined maintenance programs to clean the fluid path.

Run these programs daily:	See page:
DAY_RINSE	page 77
OVERNIGHT_LOOP	page 78
RINSE_AND_SOAK	page 78
Run these programs as needed:	See page:
LONG_SHUTDOWN	page 91
DECONTAMINATION	page 87

For all daily maintenance programs, fill the supply bottle with at least 200 mL of rinse solution and empty the waste bottle.

To run a maintenance program:

1. Fill the supply bottle with an appropriate cleaning agent for the fluids you have been dispensing.
2. Select **Maintenance** from the Main Menu.
3. Select the desired maintenance program.
4. Press **START** to begin. (To stop a program in progress, press Abort.)

8F/8MF models: Vacuum Filtration Maintenance

Run the predefined link protocol **VAC30_TEST** with disinfectant as the fluid supply to clean the tubing and hardware used to perform filter plate assays.

DAY_RINSE

Flush the washer with an appropriate reagent at the beginning of the day, using a buffer solution *on the same day the microplates are washed*. This helps prevent the

aspirate and dispense tubes from clogging between washes.

AutoPrime

AutoPrime keeps the tubing wet to prevent clogging during idle periods. It is highly recommended for daily and overnight maintenance.

AutoPrime automatically primes the washer when it has been idle for a user-specified amount of time. AutoPrime is recommended when the washer is used intermittently throughout the day, to keep the manifold tubes in a wetted condition between runs. It is especially useful when using wash buffers that are prone to harden or crystallize. See [AutoPrime](#) on page 40.

Enable AutoPrime

1. Select **Instrument** at the Main Menu.
2. Select **AutoPrime** and touch **Disabled** to change it to **Enabled**.
3. Touch each field to change its parameters.
4. Return to **Home**. Notice the "AutoPrime ON" message.

Overnight/Multi-Day Maintenance

Overnight/multi-day maintenance involves flushing all wash solution out of the instrument, and then periodically rinsing and soaking the tubes to keep them moist. If the washer will be left idle for a period of time (such as overnight or over a weekend), run this program to soak the tubes for several hours at a time.

The **OVERNIGHT_LOOP** and **RINSE_AND_SOAK** programs satisfy overnight/multi-day maintenance requirements.

- The **OVERNIGHT_LOOP** program requires the washer to remain turned on. The program will run continuously for 48 hours.
- As an alternative, run **RINSE_AND_SOAK** and turn off the washer after the soak begins. This leaves the tubes soaking in the priming trough until the instrument is turned on again.

Removing Protein Residuals and Fungi Growth

Important: Solutions containing proteins, such as bovine serum albumin (BSA), will compromise the washer's performance over time unless a strict maintenance regime is adhered to. **Do not use alcohol to flush out BSA.**

BioTek recommends performing the following additional maintenance procedures to thoroughly flush out protein particles and other contaminants from the washer's fluid path, when necessary:

Daily

Using PBS or an enzyme-active detergent (like Terg-a-zyme):

If the washer will be idle between plates for longer than 45 minutes, flush the proteins from the washer:

1. Fill a supply bottle with PBS and connect it to the washer.
2. Run DAY_RINSE.
3. Enable AUTOPRIME for 60-minute intervals.

At the end of the day:

1. Fill a supply bottle with PBS or an enzyme-active detergent and connect it to the washer.
2. Run DAY_RINSE three times.
3. Fill a supply bottle with DI water and connect it to the washer.
4. Run DAY_RINSE three times.
5. Run OVERNIGHT_LOOP.

Weekly

Using an Enzyme-Active Detergent:

1. Mix an enzyme-active detergent according to the manufacturer's directions to fill a supply bottle. Connect the bottle to the washer.
2. Run RINSE_AND_SOAK.
3. If you plan to use the washer immediately, run DAY_RINSE twice with deionized water and once with PBS.

Periodically/Monthly



Using an Enzyme-Active Detergent:

1. Mix an enzyme-active detergent according to the manufacturer's directions to fill a supply bottle. Connect the bottle to the washer.
2. Run the DECONTAMINATION program. When the program pauses and displays CONNECT RINSE BOTTLE, leave the detergent bottle connected and continue. Repeat this sequence until the bottle is empty.
3. Connect a bottle containing deionized water and run DAY_RINSE three times to flush the system.

Clean Components

Periodic Maintenance

Periodic maintenance involves cleaning the washer components on a regular basis to keep the washer running efficiently and in compliance with instrument specifications. The recommended **frequency for cleaning washer components** is *at least monthly*. Risk and performance factors associated with your assays may require performing some or all of the procedures more frequently.

	<p>Warning! Internal Voltage. Always turn off and disconnect the instrument from its power supply for all cleaning operations.</p>
	<p>Important! Do not immerse the instrument, spray it with liquid, or use a "wet" cloth. Do not allow the cleaning solution to run into the interior of the instrument. If this happens, contact the BioTek Service Department.</p> <p>Do not soak the touchscreen—this will cause damage. Moisten a clean cloth with deionized or distilled water and wipe the touchscreen. Dry immediately with a clean, dry cloth.</p> <p>Do not apply lubricants to manifold gasket, manifold channel end seals, fittings, tubing connections, or any surface that is part of the fluid path. The use of any lubricant on the fluid handling components will interfere with the aspirating and dispensing performance, and may cause irreparable damage to these components.</p>

Maintenance Tools and Supplies

- 70% isopropyl alcohol
- Deionized or distilled water
- Dish soap or other mild cleaner
- [Tools for cleaning dispense and aspirate tubes on page 83](#)
- Phillips head screwdriver
- Lint-free disposable towels
- Soft-bristled brush

Clean the Bottles

- Clean the supply and waste bottles with DI/distilled water before the first use, before each refill, and if they have been idle for any length of time.
- Accumulated algae, fungi, or mold may require decontamination. [Decontaminate the Washer on page 87.](#)
- Empty the waste bottle. Rinse the cover every time the wash or rinse bottles are filled. Periodic decontamination may be required. Do not allow the waste bottle to overfill!

Clean the Touchscreen

- Never spray solutions directly on the touchscreen.
- Turn off the instrument before cleaning.
- Moisten a soft, lint-free cloth with water and ring out thoroughly. **Do not use a dripping cloth.**
- Avoid fibrous material that can scratch the surface.

Important: If necessary, only use the recommended [Cleaning solutions:](#) and do not use a higher concentration of the solutions.

- If a cleaning solution is used, wipe again with a cloth dampened with water only and dry with a clean cloth.

Clean the Exterior Surfaces

1. Run the system “dry”: connect an empty supply bottle, and prime the washer until the tubing is empty.
2. Turn off and unplug the washer.

3. Moisten a lint-free disposable towel with water, or with water and mild detergent. **Use a damp - not dripping - cloth.**
4. Wipe the top surface of the instrument base, and all exposed surfaces of the instrument.
5. If detergent was used, wipe all surfaces with a cloth moistened with water.
6. Use a clean, dry cloth to dry all wet surfaces.

Clean the Carrier

If liquid has overflowed onto the microplate carrier, some crystal buildup may occur, preventing the microplate from seating correctly on the carrier. The vacuum filtration carrier of 8F/8MF models may also have residual buildup, which can prevent proper seating of filter or membrane plates.

Standard and Biomagnetic Separation Microplate Carriers

Important: Each microplate carrier is uniquely aligned for each washer. **Do not** adjust the nylon screws or interchange the carrier with another.

1. Turn the washer on, wait for the self-test to complete, then, turn the washer off.
2. Remove the carrier and clean it with soap and water or 70% isopropyl alcohol.
3. Replace the carrier.

See [Install the Microplate Carrier on page 27](#)

Vacuum Filtration Carriers

1. Disconnect the tubing between the vacuum filtration carrier and washer and lift the carrier out of the base (if applicable).
2. Rinse the carrier under tap water and allow to dry.
 - If additional cleaning appears necessary, soak the carrier in hot, soapy water for 20 minutes. Rinse it well and let it dry.
 - Inspect the plate seal gasket and replace it if defects are observed: [Vacuum Filtration Carrier: Replace the Gasket](#).

Vacuum Filtration Carrier Maintenance

Run the predefined link protocol **VAC30_TEST** with disinfectant or DI water as the fluid supply to clean the tubing and hardware. Do not put a plate on the carrier.

1. Connect a supply bottle filled with 60 mL of disinfectant or water.
2. Insert the black vent plug into the vent port on the front of the carrier.

3. Select **VAC30_TEST**.
4. When the run is completed, if disinfectant/detergent was used, rerun the protocol once or twice with DI water.

Clean the Mist Shield

1. Remove the mist shield.
2. Wipe inside and outside surfaces of the mist shield with a lightly moistened towel. Let it air dry.
3. Reinstall the mist shield.

Clean the Manifold

- The manifold dispense tubes have a protective Teflon collar at the tip. This is to prevent dripping. **Do not remove these coverings!**

Regular rinsing helps keep the manifold clean, the aspirate and dispense tubes clear, and increases the life of the tubing.

1. Disconnect the tubing from the back of the manifold.
2. Remove the thumbscrews that hold it in place and clean the manifold:
 - Using a lint-free disposable towel moistened with water, or with water and mild detergent, thoroughly clean the outside of the dispense and aspirate tubes.
 - Run hot water through both the inlet and outlet fittings. Check to see if water comes out of all of the dispense and aspirate tubes. If not, soak the manifold in hot soapy water and try again.

Performance problems like uneven aspiration or dispensing are typically caused by clogged tubes. When necessary:

- See [Decontaminate the Washer](#) on page 87 to disinfect the manifold and tubing;
- Most importantly: See [Clean the Aspirate and Dispense Tubes](#) on the next page.

Tools for cleaning dispense and aspirate tubes

BioTek provides custom styluses for unclogging dispense and aspirate tubes:

Color	Manifold	Wire Diameter	Part Number	In Kit PN
Yellow	8,16 Well	0.018"	7772030	1550508
Black	All manifolds' aspirate tubes & 8s dispense tubes	0.025"	7772032	1550506 1550508
White	All manifolds except 8,16 and 8s	0.020"	7772031	1550506

Clean the Aspirate and Dispense Tubes

- The manifold dispense tubes have a protective Teflon collar at the tip. This is to prevent dripping. **Do not remove these coverings!**

8, 8s, 12, 2x8, or 4 Well Manifold:

1. Remove the manifold:
 - Disconnect the tubing from the back of the manifold.
 - Remove the thumbscrews that hold it in place.



Disassembled 8-channel manifold

2. Use a Phillips screwdriver to remove the metal plate on top of the manifold (eight screws). Remove the gasket (rubber top seal).
3. Clean the dispense and aspirate chambers on the manifold top with hot soapy water and a soft-bristled brush. Thoroughly clean the walls of the chambers.
4. Clean the insides of the aspirate and dispense tubes with the appropriate stylus (aspirate or dispense).
5. Rinse the manifold with deionized or distilled water. Look through the tubes to ensure tube openings are clear.
6. When satisfied, replace the gasket and metal plate. Do not overtighten.
7. Remount the manifold and replace the tubing.
8. Replace the mist shield.
9. Run a Prime program using 200 mL.
10. Verify dispenser performance visually or by completing the [Dispense Precision Test 8, 8s, 2x8, and 12 Manifolds on page 110](#).

8,16 Well Manifold:

Important: Do **not** disassemble the 8,16 Well manifold. There are five screws on the top metal plate. Removing any of these screws will cause the manifold to **fall out of alignment!**

1. Remove the manifold:
 - Disconnect the tubing from the back of the manifold.
 - Remove the three thumbscrews on top of the manifold.
 - Gently grasp the front of the manifold, holding the together the two rows of tubes and lift the manifold straight up and off.

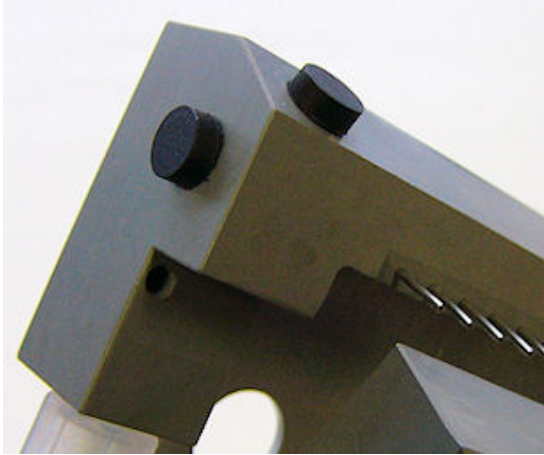

2 black plugs on left side of 8,16 manifold

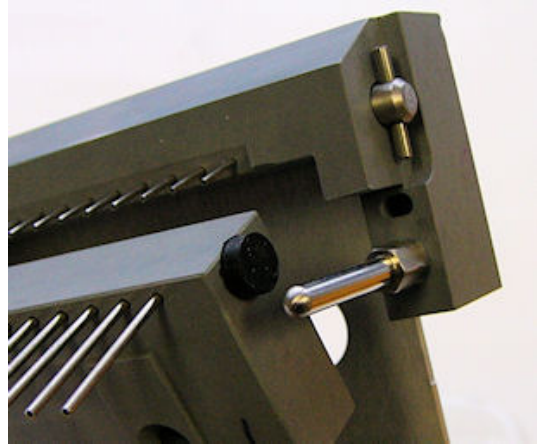

1 black plug and 1 metal T-shaped plug on right side of manifold





2. Remove the three black channel plugs and the metal T-shaped plug from the sides of the manifold.
3. Using the appropriate stylus (aspirate/dispense), clean the insides of the aspirate and dispense tubes, while flushing out the channels by holding the manifold under a running faucet of warm water. Alternate between using the stylus and flushing the channel for each tube.
4. Rinse the manifold with deionized or distilled water. Make sure water comes out of all of the dispense and aspirate tubes.
5. When satisfied, replace all of the plugs.
6. Remount the manifold and replace the tubing.
7. Replace the mist shield.
8. Run a Prime program using 200 mL.
9. Verify dispenser performance visually or by completing the [Dispense Precision Test 8,16 Well Manifold on page 115](#).

Decontaminate the Washer

Any laboratory instrument that has been used for research or clinical analysis is considered a biohazard and requires decontamination prior to handling.

Decontamination minimizes the risk to all who come into contact with the instrument during shipping, handling, and servicing. Decontamination is required by the U.S. Department of Transportation regulations. Persons performing the decontamination process must be familiar with the basic setup and operation of the instrument.

The recommended **frequency for decontamination** is at least monthly, and before shipment of the instrument to BioTek for calibration or repair.

	<p>Important! BioTek Instruments, Inc. recommends the use of the following decontamination solutions and methods based on our knowledge of the instrument and recommendations of the Centers for Disease Control and Prevention (CDC). Neither BioTek nor the CDC assumes any liability for the adequacy of these solutions and methods. Each laboratory must ensure that decontamination procedures are adequate for the Biohazard(s) they handle.</p>
	<p>Warning! Internal Voltage. Turn off and unplug the instrument for all decontamination operations.</p>
	<p>Do not immerse the instrument, spray it with liquid, or use a “wet” cloth. Do not allow the cleaning solution to run into the interior of the instrument. If this happens, contact the BioTek Service Department. Do not soak or spray the touchscreen.</p>
	<p>Wear prophylactic gloves when handling contaminated instruments. Gloved hands should be considered contaminated at all times; keep gloved hands away from eyes, mouth, nose, and ears. Eating and drinking while decontaminating instruments is not advised.</p>
	<p>Mucous membranes are considered prime entry routes for infectious agents. Wear eye protection and a surgical mask when there is a possibility of aerosol contamination. Intact skin is generally considered an effective barrier against infectious organisms; however, small abrasions and cuts may not always be visible. Wear protective gloves when performing the decontamination procedure.</p>

Decontamination Tools and Supplies

Cleaning solutions:

Important: Use the solutions as recommended: "Internal components" for cleaning and disinfecting the tubing, bottles, valves and fluid pump. "External surfaces" refer to the instrument chassis, plate carrier, and mist shield.

Internal components: bottles and tubing	External surfaces
0.5 % sodium hypochlorite (NaClO or bleach)	0.5 % sodium hypochlorite
70% isopropyl alcohol	70% isopropyl alcohol
70% ethanol	70% ethanol
	4% formaldehyde
	4% glutaraldehyde
	1-3% Virkon

- Deionized or distilled water
- Safety glasses
- Surgical mask
- Protective gloves
- Lab coat
- Biohazard trash bags
- 125 mL beakers
- Clean cotton cloths or paper towels

Decontamination (bleach) solution/disinfectant

Prepare an aqueous cleaning solution of 0.5% sodium hypochlorite (NaClO). As an alternative, 70% isopropyl alcohol may be used if the effects of bleach are a concern. Be sure to check the percent NaClO of the bleach you are using; this information is printed on the side of the bottle.

- Commercial bleach is typically 10% NaClO; if this is the case, prepare a 1:20 dilution.
- Household bleach is typically 5% NaClO; if this is the case, prepare a 1:10 dilution.

■ **Isopropyl alcohol/ethanol** is not recommended for removing **proteins** (such as bovine serum albumin).



Do not use stronger bleach solutions than recommended. Extended exposure to high concentrations of bleach can deteriorate some waste system components.

Decontaminate the External Surfaces and Components

	<p>The bleach solution is caustic; wear gloves and eye protection when handling this solution. See Cleaning solutions: on the previous page</p>
	<p>Caution! Be sure to check the percent NaClO of the bleach you are using; this information is printed on the side of the bottle. Commercial bleach is typically 10% NaClO; if this is the case, prepare a 1:20 dilution. Household bleach is typically 5% NaClO; if this is the case, prepare a 1:10 dilution.</p>
	<p>Do not prepare a stronger cleaning solution than described.</p>

1. Turn off and unplug the instrument.
2. Moisten a cloth with the bleach solution or alcohol. **Do not soak the cloth.**
3. Wipe the touchscreen (See [Clean the Touchscreen on page 81](#)).
4. Remove the mist shield, if it is attached. Wipe the inside and outside mist shield surfaces. Wipe the microplate carrier, top surface of the instrument base, supply bottles and tubing, and all exposed surfaces of the instrument.

Vacuum Filtration models: See [Decontaminate the Vacuum Filtration Carrier on the next page](#).

5. Wait 20 minutes. Moisten a cloth with DI or distilled water and wipe all surfaces that were cleaned with a [cleaning solution](#).
6. Use a clean, dry cloth to dry all wet surfaces.
7. Reassemble the instrument as necessary.
8. Discard the used gloves and cloths using a biohazard trash bag and an approved biohazard container.

Decontamination Procedure for Tubing and Manifold

- Two supply bottles are required for this procedure: one for 120 mL disinfectant, and one for 250 mL of rinse.

After decontaminating the external surfaces:

1. Connect the washer to the power supply, and turn it on.
2. Connect the disinfectant fluid supply and empty the waste bottle.
3. Run **DECONTAMINATION**. (Select **Maintenance** from the Main Menu.)

While the program is running, you will need to periodically check the display and follow instructions for changing the supply bottles.

4. Flush all the bleach/disinfectant from the instrument by running **DAY_RINSE** at least once with DI water.

Decontaminate the Vacuum Filtration Carrier

First, disinfect the tubing, then, remove and soak the carrier:

Decontaminate the tubing:

Run the predefined protocol **VAC30_TEST** with disinfectant as the fluid supply to clean the tubing and hardware used to perform filter plate assays.

1. Connect a supply bottle filled with 200 mL of [Decontamination \(bleach\) solution/disinfectant](#).
2. Insert the black vent plug into the vent port on the front of the carrier.
3. First prime the tubing.
4. Select **VAC30_TEST**.
5. When the run is completed, replace the decontamination fluid supply with DI water and rerun it once or twice.

Decontaminate the vacuum filtration carrier:

1. Turn off and unplug the instrument.
2. Disconnect the tubing from the back of the aspiration carrier.
3. Remove the carrier and soak it in the Decontamination (bleach) solution for 20 minutes.

4. Rinse the carrier thoroughly to remove all bleach.
5. Use a clean, dry cloth to dry all wet surfaces.

Inspect the plate seal gasket and replace it if defects are observed: See [Vacuum Filtration Carrier: Replace the Gasket on page 94](#).

Alternate Decontamination Procedure for Tubing and Manifold

If you are unable to run the decontamination program due to a system failure, decontaminate the internal tubing and manifold parts as follows:

1. Turn off and unplug the instrument.
2. Remove the tubing and manifold.
3. Soak the tubing and manifold in the bleach or alcohol solution.
4. Wait 20 minutes. Rinse the tubing and manifold with DI water.
5. Use a clean, dry cloth to dry all wet surfaces of the tubes and manifold.
6. Reassemble the instrument as necessary.
7. Discard the used gloves and cloths using a biohazard trash bag and an approved biohazard container.

Prepare for Storage or Shipment

Before the washer is shipped or stored it must be rinsed and soaked with disinfectant, and purged of fluid.

About Long_Shutdown

BioTek provides an onboard Maintenance program, **LONG_SHUTDOWN**, to perform three steps:

1. Flush and soak the supply tubing and manifold with disinfectant.
2. Flush the system with rinse.
3. Purge the system of fluid.

Run Long_Shutdown

- Three supply bottles are required for this procedure: one for disinfectant, one for rinse, and one for air. Obey the prompts

■ **Caution!** Be sure to check the percent NaClO of the bleach you are using; this information is printed on the side of the bottle. Commercial bleach is typically 10% NaClO; if this is the case, prepare a 1:20 dilution. Household bleach is typically 5% NaClO; if this is the case, prepare a 1:10 dilution.

1. Turn off the instrument. Empty the waste bottle.
2. Prepare the [Decontamination \(bleach\) solution/disinfectant](#) (as described on page 88).
3. Fill one supply bottle with at least 200 mL of bleach solution.
4. Fill another supply bottle with at least 400 mL of rinse (deionized water).
5. Keep the third supply bottle empty (air).
6. If the washer is equipped with the Buffer Switching (“V” models), connect the supply bottles this way:
 - Valve A:** Disinfectant bottle
 - Valve B:** Rinse solution bottle
 - Valve C:** Empty bottle
7. Turn on the washer and run LONG_SHUTDOWN: select **Maintenance>LONG_SHUTDOWN**, and respond to the prompts.

■ **Note:** While this program is running, you will need to periodically check the display panel and follow the instructions for changing the supply bottles.

Storing the Washer

After performing the **Long_Shutdown** procedure:

1. Turn off the washer and disconnect the power cord.
2. Store the washer on a flat surface that is relatively free of vibration, in a dust-free and particle-free environment.
3. Protect the washer from temperature extremes that can cause condensation within the unit and from corrosive fumes and vapors.
4. Store the washer under the following environmental conditions:
 - **Temperature:** -20°C to 50°C (-4°F to 122°F)
 - **Relative humidity:** 10% to 85% (non-condensing)

■ **Note:** Allow the washer to reach room temperature before use after storage.

Replace Components

Contact BioTek to order needed spare parts when the original components begin to show wear.

Replacement (Spare) Parts Listing

Replacement Parts	Part Number (PN)
Rubber stopper for waste bottle	4072034
Vacuum inline filter	48146
Vacuum pump muffler (washers shipped after Jan. 2008)	4073009
Check valves	68061
Manifold gasket (rubber seal) for 8- and 12 Well manifolds	4072012
Manifold gasket (rubber seal) for 2x8 Well manifolds	1552011
Manifold gasket (rubber seal) for 4 Well manifolds	4072012
8,16 Well manifold: Channel end seals/plugs	49486
8,16 Well manifold: T-plug	4072070
8,16 Well manifold: T-plug O-ring	49484
Manifold cam O-ring	45045
8F/8MF models:	
Vacuum filtration carrier gasket	4072096
Vent plug O-rings for vacuum filtration carrier (2 per plug)	19497

- Part numbers are subject to change. Please contact BioTek Customer Care if you have any questions.

Replace (or Clean) the Check Valves

In the event that the check valves become stuck or leak, you can either clean or replace them. To replace a check valve, contact BioTek Customer Service.

[Replacement Spare Parts Listing on the previous page.](#)

- Replacing the check valves is easier than cleaning them.

To clean a check valve:

1. Separate the check valve from the tubing.
2. Insert the stylus into the feed end of the valve to hold it open (observe the arrow on the valve indicating the feed direction).
3. Flush with hot water.

If necessary, the check valve body twists open to allow disassembly and cleaning of internal components. Note proper orientation for reassembly.

4. Replace the valve and the tubing.

Vacuum Filtration Carrier: Replace the Gasket

If you observe damage to the vacuum filtration carrier's gasket, you must order a replacement part from BioTek, and follow these instructions to replace it.

1. Remove the carrier from the instrument and put on a level work surface.
2. If applicable, lift the carrier's plate clamp and leave it open.
3. With a Philips screwdriver, remove the six screws around the perimeter of the top of the carrier.
4. Lift off and set aside the top plate, and remove the gasket.
 - If the grate (located under the gasket) needs to be cleaned, rinse it under tap water. Allow the grate to dry before placing it and the gasket in the carrier.
5. Place the new gasket in the carrier, correctly positioning the notch with the corresponding indentation on the carrier's right side.



The gasket fits only one way on the carrier. When replacing it, align the notch in the gasket with the small "bump" on the carrier.

6. Restore the top plate and its six screws. Do not overtighten. If applicable, close the plate clamp and reinstall the carrier.
7. Verify vacuum filtration performance by performing the [Vacuum Filtration Evacuation Efficiency Test](#)

< 4.0 % for 4 Well																						
Vacuum Filtration Testing:																						
Perform Evacuation Efficiency Test: All wells evacuated																						
If Millipore MSHVN4550 plate used, Residual Weight: <= 1.2 g																						
Operator's Initials																						

* Review previous test results for any trends.

Qualification

This chapter provides instructions for periodically testing the washer to verify that it meets performance specifications.

About Instrument Qualification	100
IQ/OQ/PQ	101
Qualification Schedule	102
Liquid Tests	104
Self-Test	109
Dispense Precision Test (8, 8s, 2X8, and 12 Well)	110
Annual Buffer Switching Dispense Precision Test	112
Evacuation Efficiency Test (8, 8s, 2X8, and 12 Well)	113
Vacuum Filtration Evacuation Efficiency Test	114
Dispense Precision Test (8,16 Well)	115
Annual Buffer Switching Dispense Precision Test	117
Evacuation Efficiency Test (8,16 Well)	118
Dispense Precision Test (4 Well Manifold)	119
Evacuation Efficiency Test (4 Well Manifold)	120

About Instrument Qualification

Instrument qualification for the 50 TS involves three activities: qualifying installation and setup, qualifying wash, dispense and aspirate routines, and qualifying long-term stability. This is referred to as Installation Qualification (**IQ**), Operational Qualification (**OQ**), and Performance Qualification (**PQ**), respectively.

Testing includes:

- The **System Self Test** verifies system components, such as the vacuum, manifold, and carrier positioning.
- **Evacuation Efficiency**: This test measures the residual volume per well after the aspiration step of plate washing. The lower the residuals per well, the better the evacuation efficiency of the washer.
- The **Evacuation Efficiency Test for Vacuum Filtration** verifies that the washer effectively aspirates fluid from the wells of a 96-well filter microplate. The test measures the total residual volume of the plate after evacuation to verify it is performing to specifications.
- **Dispense Precision**: This test measures the variability of volumes dispensed from tube to tube across the manifold.
- **Annual Buffer Switching Test**: Measures the variability of volumes dispensed for each valve, when the washer is used with this valve-switching feature.

■ **Note:** An **instrument qualification package** (PN1550510) for the washer is available for purchase. The package contains thorough procedures for performing Installation Qualification, Operational Qualification and Performance Qualification (IQ-OQ-PQ) and maintenance. Checklists and Logbooks are included for recording results. Contact your local dealer or BioTek for more information.

IQ/OQ/PQ

Installation Qualification (IQ) confirms that the washer and its components have been supplied as ordered and ensures that they are assembled and configured properly for your lab environment.

- The recommended IQ procedure consists of setting up the instrument as described in the Installation chapter and then performing the System Self-Test. The IQ procedure should be performed *initially* (before the washer is used for the first time).
- The successful completion of the IQ procedure verifies that the instrument is installed correctly. The Operational Qualification procedure should be performed immediately following the successful IQ.

Operational Qualification (OQ) confirms that the washer operates according to specification initially and over time.

- The recommended OQ procedure consists of performing the System Self-Test, Evacuation Efficiency, and Dispense Precision tests. Your facility's operating policies may also require that you perform an actual assay prior to accepting the washer for routine use. You should not use the data obtained from the first assay that performed on the washer until you have confirmed that the package insert criteria have been met.
- The OQ procedure should be performed *initially* (before first use) and then routinely; the recommended interval is *annually*. It should also be performed after any major repair or upgrade to the hardware or software.
- Although out-of-tolerance failures will be detected by the OQ tests, results should be compared with those from the monthly Performance Qualification tests and previous OQ tests to monitor for trends.
- The successful completion of the OQ procedure, in combination with results that are comparable to previous PQ and OQ tests, confirms that the washer is performing consistently over time.

Performance Qualification (PQ) confirms that the washer consistently meets the requirements of the tests performed at your laboratory.

- The recommended PQ procedure consists of performing the System Self-Test, Evacuation Efficiency, and Dispense Precision tests. Your facility's operating policies may also require that you routinely perform an actual assay, to confirm that the washer will consistently give adequate results for the assays to be run with it.
- These tests should be performed routinely; the recommended interval is *monthly*. This frequency may be adjusted depending on the trends observed over time.
- The successful completion of the PQ procedure confirms that the washer is performing consistently under normal operating conditions.

Qualification Schedule

The following schedule defines the recommended intervals for verification tests for a washer used two to five days a week. The schedule assumes that the washer is properly maintained as outlined in [Recommended Maintenance Schedule on page 72](#).

Recommended Performance Qualification Schedule

TASK	Installation Qualification	Operational Qualification	Performance Qualification
		Initially & Annually	Monthly
System Self-Test	✓	✓	✓
8, 8s, 12 Well Manifolds:			
Evacuation Efficiency Test		✓	✓
Dispense Precision Test		✓	✓
Annual Buffer Switching Test		✓*	
8,16 Well Manifold:			
Evacuation Efficiency Test		✓	✓
Dispense Precision Test		✓	✓
Annual Buffer Switching Test		✓*	
4, 2x8 Well Manifolds:			
Evacuation Efficiency Test		✓	✓
Dispense Precision Test		✓	✓
Vacuum Filtration models:			
Vacuum Filtration Evacuation Efficiency Test		✓	✓

* Annual Buffer Switching testing can begin after first year of use.

- It is important to note that the risk and performance factors associated with your assays may require that some or all of the procedures be performed more frequently than presented in the schedule.

Which Tests to Perform?

We recommend that you perform these routine tests on all manifolds before first use (after the IQ) and then monthly:

- **Dispense Precision Test:** Measures the variability of volumes dispensed from tube to tube across the manifold.
- **Evacuation Efficiency Test:** Measures the residual volume per well after the aspiration aspect of plate washing. The lower the residuals per well, the better the evacuation efficiency of the washer.
- **50 TS/8F and 8MF models: Vacuum Filtration Evacuation Efficiency Test** Measures the total residual volume of the plate after evacuation to verify it is performing to specifications.

If your washer is equipped with Buffer Switching ("V" models), we recommend performing this additional test annually (starting one year after installation):

- **Annual Buffer Switching Test.** Measures the variability of volumes dispensed for each valve, when the washer is used with this valve-switching feature.

- If you are testing a biomagnetic-separation ("M") model using the magnetic bead carrier, do not perform these tests with the magnet in the carrier.

Liquid Tests

Evacuation Efficiency Test

The Evacuation Efficiency Test measures the **residual volume** (mean residual weight) per well after aspiration. The lower the residual per well, the better the evacuation efficiency of the washer. A known solution is dispensed into all wells of a previously weighed microplate. The aspiration program is run and the plate is reweighed in order to calculate the total residual fluid based on the weight difference. The total residual fluid weight is divided by the number of wells to obtain the **mean residual weight**.

Dispense Precision Test

The Dispense Precision Test measures the **variability of the volumes dispensed** from tube to tube across the manifold. In this test, a blue dye solution is dispensed into a microplate. The optical density of each well is measured at 630 nm and the background at 450 nm is subtracted to account for scratches on the plate or particulates in the well. The average error percentage is calculated and the amount dispensed to each well is calculated. Acceptance is based on the **%CV** (%Coefficient of Variation), or the ratio of the standard deviation of the distribution of fluid volumes in the wells to the mean value of volume per well. The lower the %CV, the better the uniformity across the manifold.

Annual Buffer Switching Test: The Dispense Precision test is conducted for the external Buffer Switching valve module to ensure that each valve is calibrated to deliver the same volume of fluid. Each valve is calibrated at the factory prior to shipment. The valves are stable over time, thus the recommended test frequency is annually.

Materials

- One **new** microplate per test to be performed:

Microplate Type	Liquid Tests
8, 8s, 12, 2x8 Well Manifold Tests	
Flat-bottom 96-well plates, Corning® Costar #3590 (or equivalent)	Dispense Precision Test
	Evacuation Efficiency Test
	Annual Buffer Switching Test (if applicable), one plate per valve tested
4 Well Manifold Tests	
24-well Corning 3524 plate (or equivalent)	Dispense Precision Test
	Evacuation Efficiency Test
8,16 Well Manifold Tests	
Flat-bottom 384-well plates, Corning Costar (or equivalent)	Dispense Precision Test
	Evacuation Efficiency Test
	Annual Buffer Switching Test (if applicable), one plate per valve tested
50 TS/8F and 8MF Models Test	
96-well filter plate, Millipore® MSHVN4550 96 (or equivalent 0.45 micron filter plate)	Vacuum Filtration Evacuation Efficiency Test

- Precision balance with capacity of 100 g minimum and readability of 0.001 g resolution
- Pipettes and graduated beakers
- Microplate absorbance reader capable of dual wavelength reading at 630 and 450 nm
- Liquid Test Worksheets at the end of this chapter for recording data and results
- Deionized water

Test solutions

Solution #1: 0.1% Tween 20 in deionized water

- Pipette 1 mL Tween 20 into 1 liter (1000 mL) of deionized water and mix well, **or**
- Pipette 10 mL of BioTek Solution #1 100X Concentrate Wetting Agent (PN 7773002) into 1 liter of deionized water and mix well.

Solution #2: Residual Test Solution

- Mix 100 mL of Solution #1 with 0.0500 grams of FD&C #1 blue dye, **or**
- Mix 10 mL of BioTek Solution #2 10X Concentrate Blue Test Dye (PN 7773001) with 90 mL of Solution #1 prepared above

Solution #3: Dispense Precision Solution

- Mix 590 mL of deionized water with 10 mL of either Solution #2 prepared above.

Solution #1, PN 7773002 contains 10% Tween[®] 20 in deionized water and 0.01% Sodium Azide as a preservative. **Solution #2, PN 7773001** contains 5 g per liter of FD&C Blue #1, 0.1% Tween 20 in deionized water, and 0.01% Sodium Azide as a preservative.

Using **pure deionized water** in place of Solution #1 is not recommended and will likely result in the failure of the washer to meet specifications.



Prepare the solutions a few hours before running the tests to let the foam created by mixing the Tween solution to settle.

You may use **your own buffer solution** in place of Solution #1. However, if any tests fail retry the tests using the specified solutions.

■ **Important:** BioTek determined the pass/fail specifications for the tests using the specified test solutions.

Liquid Test Worksheets for recording results are provided at the end of this chapter. If your tests are failing, this information will be useful for BioTek TAC to help diagnose any problems.

Liquid Test Protocols: Default Parameters

Note: For washers with **Buffer Switching** the predefined protocols are set to use Buffer "A." If you would prefer to use a different buffer, create your own test protocols using these parameters.

Evacuation Efficiency Tests				
	residual_qc_test		resid_qc_test384	
Aspirate Height: Z Offset	28 steps	3.56 mm	22 steps	2.79 mm
Y Offset Position	-20	-.91 mm	00	0 mm
Aspirate Travel Rate	1	5.0 mm/sec	3	5.8 mm/sec
Aspirate Delay	0000		0000	
Secondary Aspirate	No		No	

Dispense Precision Tests		
	accuracy_qc_test	accuracy_qc384
Dispense Volume	300 µL/well	100 µL/well
Dispense Flow Rate	5	6
Dispense Height: Z Offset	146	120
Y Offset	00	00
Prime Before Start	Yes	Yes
Prime volume and flow rate	9 mL at rate 5	5 mL at rate 5

Vacuum Filtration models: 96-well filter plates	
Protocol Name	VAC30_TEST

Vacuum Filtration models: 96-well filter plates	
Prime Volume and Flow Rate	5 mL at rate 5
Dispense Volume and Flow Rate	300 µL at rate 5
Dispense Height: Z Offset	146
Aspiration Type	Vacuum Filtration
Vacuum Filtration Time	30 seconds

4 Well Manifold Test Parameters

Evacuation Efficiency Test	Residual QC Test	
Aspirate Height: Z Offset	13 steps	1.65 mm
Y Offset Position	-90	4.11 mm
Aspirate Travel Rate	1	5.0 mm/sec
Aspirate Delay	2000 msec	
Secondary Aspirate	No	

Dispense Precision Test	Accuracy QC Test
Dispense Volume	1120 µL/well
Dispense Flow Rate	5
Dispense Height: Z Offset	180 steps (22.87 mm)
Y Offset	00
Prime Before Start	Yes
Prime volume and flow rate	5 mL at rate 5

Self-Test

The Self-Test is performed automatically whenever the instrument is turned on. It can also be performed manually from the Main Menu:

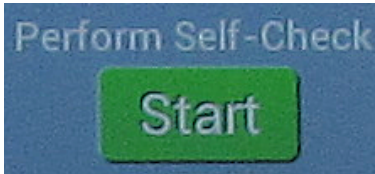

Select **Instrument>Options** and press Start.

- The **Self-Test** checks the vacuum, manifold, and manifold-to-carrier movement.

If the test passes, the Main Menu is displayed and the washer is ready for use. If the test fails, the washer will beep and display an error code. Press **OK** and look up the code, [Error Codes on page 134](#)

Dispense Precision Test (8, 8s, 2X8, and 12 Well)

■ For washers with **Buffer Switching** the predefined protocols provided are set to use Buffer "A." If you would prefer to use a different buffer, create your own dispense test protocol using the [Liquid Test Protocols: Default Parameters on page 107](#). Prime the system with the selected "Buffer" before running tests if the washer has been idle.

■ When this test is complete, the filled plate can be used to perform the **Evacuation Efficiency Test**.

1. Use a clean, dry 96-well microplate. If you will be using the same plate for the **Evacuation Efficiency Test**: place a new plate on the balance and tare the balance.
2. Prepare the washer to dispense test **Solution #3** to the microplate ([Test solutions on page 106](#)): fill a supply bottle and prime the tubing and the manifold (**Quick>Prime>System**).
3. Run the dispense program **accuracy_qc_test**. Enter the number of strips to process (**12** for the 8/8s and 2X8 Well manifolds; or **8** for the 12 Well manifold).
4. Read the plate in an absorbance reader (blank on air) using the dual-wavelength method (630-450 nm). Print or export the results.

■ **Note:** If you are using one of BioTek's keypad-based readers, such as the ELx800™ or ELx808™, ensure that the reader is not running in Rapid mode. To check this, select UTIL>READ and cycle through the prompts until you see READ IN RAPID MODE?, then choose NO for an accurate result.

5. Calculate and report the mean absorbance, standard deviation, and % Coefficient of Variation (%CV) for the plate using the worksheets at the end of the chapter.

Performance specifications — a %CV greater than:

- 3.0% is a failure for the 8, 8s, and 12 manifolds
- 4.0% is a failure for the 2X8 manifold

If your %CV result fails, clean the dispense tubes with a stylus and retest.

Example:**Data:**

Mean Absorbance = $\langle OD \rangle$ = 1.026

Standard Deviation = SD = 0.010

Calculation:

% Coefficient of Variation = $\frac{SD}{\langle OD \rangle}$ = $\frac{0.010}{1.026}$ x 100 = 0.98%

If this test does not pass on the initial attempt, use the stylus to clean the dispense tubes that have OD reading results lower than average, and then retest.

Annual Buffer Switching Dispense Precision Test

Perform this test during the annual **OQ** for the 8, 8s, or 12 Well manifold.

■ Only applies to “**V**” model washers.

■ The Dispense Precision Test ([page 110](#)) must pass for one valve before the annual test for all valves can be performed.

1. Empty the waste bottle now, and then as needed throughout this procedure.
2. Fill each of the supply bottles connected to **Valves A, B, and C** with approximately 200 mL deionized water.

Repeat the following steps for each valve:

3. Run the Maintenance program **DAY_RINSE** to prime the fluid lines, manifold, and the valve being tested.
4. Place a new 96-well microplate on the balance and zero the balance.
5. Place the microplate on the carrier and run the dispense program **accuracy_qc_test**. The program dispenses 300 μ L to each well of the plate. It does not evacuate the wells.
6. When the program is finished, carefully remove the plate and weigh it. This is the **Total Dispense Weight** in grams.
 - The Total Dispense Weight should be **28.8 grams, $\pm 10\%$** (between 25.92 g and 31.68 g).
 - If the weight falls above this range, the valve may be defective. Contact BioTek.
 - If the weight falls below this range, the valve may be contaminated with fungi or proteins and should be cleaned using an appropriate enzyme, alcohol, or a diluted bleach solution, depending on the contaminant.

See [Decontaminate the Washer on page 87](#) for suggestions. After cleaning the valve and tubing, retry the test. If the test continues to fail, contact BioTek.

7. Calculate and report the results of the “Annual Buffer Switching Module Test” in the worksheet at the end of this section.

Evacuation Efficiency Test (8, 8s, 2X8, and 12 Well)

■ If you tared the balance at the start of the Dispense Precision Test (on [page 110](#)) you can use the plate from that test here; **skip steps 1-3**.

1. Fill a supply bottle with at least 200 mL of **deionized water**. Run Maintenance program **DAY_RINSE** to prime the fluid lines and manifold.
2. Place a new 96-well microplate on the balance and tare the balance.
3. Pipette or dispense 300 µL of **Solution #1, 2, or 3** (your choice) into each well of the microplate.
4. Place the plate on the washer and run the Aspirate program **residual_qc_test**. This program evacuates all of the wells, leaving a small amount of residual fluid.
5. When the program is finished, remove the plate and weigh it immediately, because evaporation will affect the results. This is the **Total Residual Weight**, in grams.
6. Visually inspect the plate and note if any wells appear to have considerably more liquid in them than others.
7. Using the worksheet at the end of this chapter, calculate and report the results:
 - Divide the Total Residual Weight by **96** to find the **Mean Residual Weight**.
 - The Mean Residual Weight should be:
 - **<= 0.002 g** for the 8, 8s, and 12 manifolds
 - **<= 0.004 g** for the 2x8 manifold

If the Mean Residual Weight is greater than the limit above, or if one or more wells appear to have much more liquid than the others, the washer failed the test.

If the test fails, troubleshoot as follows:

- If the problem appears to be related to particular wells, clean those aspiration tubes, [See Clean the Aspirate and Dispense Tubes on page 84](#). When finished, retry the test.
- Failure may occur when a microplate other than the recommended Corning® Costar 96 is used. If you prefer to use a different plate, create a new protocol based on the original **residual_qc_test** but change the Aspirate height (Z Offset) or other parameters to accommodate the different plate geometry. Then, retry the test using a new microplate. (See [Liquid Test Protocols: Default Parameters on page 107](#).)

- Review possible causes of poor aspiration in the Troubleshooting section: [See Fluid Aspiration on page 146.](#)

If the test fails a second time: contact BioTek TAC for assistance.

Vacuum Filtration Evacuation Efficiency Test

This test is designed for 50 TS models with Vacuum Filtration. Install the vacuum filtration plate carrier to perform the test.

Perform this test during the **annual OQ**, and the **monthly PQ**.

1. Fill a supply bottle at least 200 mL of **deionized water**. Run Maintenance program **DAY_RINSE** to prime the fluid lines and manifold.
2. Place a new microplate on the balance and zero the balance: 96-well 0.45 µm filter plate: Millipore MSHVN4550 96 is recommended.
3. Run the protocol to first dispense DI water into each well of the microplate and then evacuate the wells: **VAC30_TEST**.
4. When the protocol is finished, remove the plate, and blot the bottom of the plate on a paper towel to remove any droplets.
5. Weigh the plate immediately. This is the **Total Residual Weight**, in grams.
6. Visually inspect the plate and note if any wells appear to have considerably more liquid in them than others.
7. Calculate and report the “Vacuum Filtration Evacuation Efficiency Test” results in the worksheet at the end of this chapter. The **Residual Weight** should be **<= 01.2 g**.

■ Although BioTek recommends that you use the Millipore filter-bottom plate listed above for this test, you may substitute other manufacturers’ filter-bottom plates that you are most familiar with using. Using a substitute plate, however, **may vary your test results**.

If the Residual Weight is greater than specified, the washer failed the test. Make sure a tight seal was maintained between the filter plate and plate carrier:

- A new, defect-free 96-well filter plate, BioTek PN 98258, was used.
- The vacuum filtration plate carrier’s gasket is clean and has not been damaged by previous use or mishandling.

Correct these conditions and rerun the test or contact BioTek TAC for assistance.

Dispense Precision Test (8,16 Well)

■ For washers with **Buffer Switching** the predefined protocols are set to use Buffer "A." If you would prefer to use a different buffer, create your own dispense test protocol using the [Liquid Test Protocols: Default Parameters on page 107](#). Prime the system with the selected "Buffer" before running tests if the washer has been idle.

■ When this test is complete, the dispensed plate can be used to perform the **Evacuation Efficiency Test**.

1. Use a clean, dry 384-well microplate. If you will be using the same plate for the **Evacuation Efficiency Test**: place a new 384-well plate on the balance and tare the balance.
2. Prepare the washer to dispense test Solution #3 to the microplate ([Test solutions on page 106](#)): fill a supply bottle and prime the tubing and the manifold (**Quick>Prime>System**).
3. Run the dispense program **accur_gc_test384**. Enter the number of strips to process: **24**.
4. Read the plate in an absorbance reader (blank on air) using the dual-wavelength method (630-450 nm), to reduce the influence of scratches and foreign particles that could be in the well. Print or export the results.

■ **Note:** If you are using one of BioTek's keypad-based readers, such as the ELx800™ or ELx808™, ensure that the reader is not running in Rapid mode. To check this, select UTIL → READ and cycle through the prompts until you see READ IN RAPID MODE?, then choose NO for an accurate result.

5. Calculate and report the mean absorbance, standard deviation, and % Coefficient of Variation (%CV) for the plate using the worksheets at the end of the chapter, for the group of wells that were filled.

A %CV greater than 4.0% is a failure. If your result is greater than 4.0%, clean the dispense tubes with a stylus and retest.

Example:

Data:

Mean Absorbance	= <OD>	= 1.200
Standard Deviation	= SD	= 0.040

Calculation:

$$\% \text{ Coefficient of Variation} = \frac{\text{SD}}{\langle \text{OD} \rangle} \times 100 = \frac{0.040}{1.200} \times 100 = 3.3\%$$

If this test does not pass on the initial attempt, use the stylus to clean the dispense tubes that have OD reading results lower than average, and then retest.

Annual Buffer Switching Dispense Precision Test

Perform this test during the **annual OQ** for the 8,16 Well manifold.

■ Only applies to “V” model washers.

■ The Dispense Precision Test (on [page 115](#)) must pass for one valve before the annual test for all valves can be performed.

1. Empty the waste bottle now, and then as needed throughout this procedure.
2. Fill each of the supply bottles connected to **Valves A, B,** and **C** with deionized water.

Repeat the following steps for each valve:

3. Run the Maintenance program **DAY_RINSE** to prime the fluid lines, manifold, and the valve being tested.
4. Place a new 384-well microplate on the balance and zero the balance.
5. Place the microplate on the carrier and run the dispense program **accur_qc_test384**. Enter the number of strips to process: **24**. The program dispenses 100 µL to each well of the plate. It does not evacuate the wells.
6. When the program is finished, carefully remove the plate and weigh it. This is the **Total Dispense Weight** in grams.
 - The Total Dispense Weight should be **38.4 grams, ±10%** (between 34.56 g and 42.24 g).
 - If the weight falls above this range, the valve may be defective. Contact BioTek.
 - If the weight falls below this range, the valve may be contaminated with fungi or proteins and should be cleaned using an appropriate enzyme, alcohol, or a diluted bleach solution, depending on the contaminant.

See [Decontaminate the Washer on page 87](#) for suggestions. After cleaning the instrument, retry the test. If the test continues to fail, contact BioTek TAC.

7. Calculate and report the results of the “Annual Buffer Switching Module Test” in the worksheet at the end of this section.

Evacuation Efficiency Test (8,16 Well)

■ If you tared the balance at the start of the Dispense Precision Test (on page [page 115](#)) you can use the plate from that test here; **skip steps 1-3**.

1. Fill a supply bottle with approximately 250 mL of **deionized water**. Run Maintenance program **DAY_RINSE** to prime the fluid lines and manifold.
2. Place a new 384-well microplate on the balance and zero the balance.
3. Pipette or dispense 80 µL of **Solution #1, 2, or 3** (your choice) into each well of the microplate.
4. Place the plate on the washer and run the Aspirate program **residual_qc_test384**. This program evacuates all of the wells, leaving a small amount of residual fluid.
5. When the program is finished, remove the plate and weigh it immediately, because evaporation will affect the results. This is the **Total Residual Weight**, in grams.
6. Visually inspect the plate and note if any wells appear to have considerably more liquid in them than others.
7. Using the worksheet at the end of this chapter, calculate and report results:
 - Divide the Total Residual Weight by **384** to find the **Mean Residual Weight**.
 - The Mean Residual Weight should be **<= 0.004 g**

If the Mean Residual Weight is greater than 0.004 g, or if one or more wells appear to have much more liquid than the others, the washer failed the test.

If the test fails once, troubleshoot as follows:

- If the problem appears to be related to particular wells, clean those aspiration tubes: [Clean the Aspirate and Dispense Tubes on page 84](#). When finished, retry the test.
- Failure may occur when a microplate other than the recommended Corning® Costar 384 is used. If you prefer to use a different plate, create a new protocol based on the original **residual_qc_test384** but change the Aspirate height (Z Offset) or other parameters to accommodate the different plate geometry. Then, retry the test using a new microplate. (See [Liquid Test Protocols: Default Parameters on page 107](#).)
- Review possible causes of poor aspiration in the Troubleshooting section : See [Fluid Aspiration on page 146](#).

If the test fails a second time: contact BioTek TAC for assistance.

Dispense Precision Test (4 Well Manifold)

Important: You must create your own qualification test protocols for this manifold type: See [Create Qualification Protocols for 4 Well Manifold](#) on page 121. Make sure the **Instrument>Manifold** setting matches the installed 4 Well manifold.

■ When this test is complete, the filled plate can be used to perform the **Evacuation Efficiency Test**.

1. Use a clean, dry 24-well microplate. If you will be using the same plate for the **Evacuation Efficiency Test**: place a new plate on the balance and tare the balance.
2. Prepare the washer to dispense test Solution #3 to the microplate ([Test solutions on page 106](#)): fill a supply bottle and prime the tubing and the manifold (**Quick>Prime>System**).
3. Run the protocol created for the test, for example **4-Well accuracy_qc_test**. Enter **6** for the number of strips to process.
4. Read the plate in an absorbance reader (blank on air) using the dual-wavelength method (630-450 nm). Print or export the results.
5. Calculate and report the mean absorbance, standard deviation, and % Coefficient of Variation (%CV) for the plate using the worksheets at the end of the chapter.

A %CV greater than 4.0% is a failure. If your result is greater than 4.0%, clean the dispense tubes with a stylus and retest.

If this test does not pass on the initial attempt, use the stylus to clean the dispense tubes that have OD reading results lower than average, and then retest.

Evacuation Efficiency Test (4 Well Manifold)

Important: You must create your own qualification test protocols for this manifold type: See [Create Qualification Protocols for 4 Well Manifold](#) on the facing page. Make sure the **Instrument>Manifold** setting matches the installed 4 Well manifold.

■ If you tared the balance at the start of the Dispense Precision Test (on page [page 119](#)) you can use the plate from that test here; **skip steps 1-3.**

1. Fill a supply bottle with approximately 250 mL of **deionized water**. Run Maintenance program **DAY_RINSE** to prime the fluid lines and manifold.
2. Place a new 24-well microplate on the balance and zero the balance.
3. Pipette or dispense 1120 µL of **Solution #1, 2, or 3** (your choice) into each well of the microplate.
4. Place the plate on the washer and run the protocol created for the test, e.g. **4-Well residual_qc_test**.
5. When the program is finished, remove the plate and weigh it immediately, because evaporation will affect the results. This is the **Total Residual Weight**, in grams.
6. Visually inspect the plate and note if any wells appear to have considerably more liquid in them than others.
7. Using the worksheet at the end of this chapter, calculate and report the results:
 - Divide the Total Residual Weight by **24** to find the **Mean Residual Weight**.
 - The Mean Residual Weight should be **<= 0.05 g**

If the Mean Residual Weight is greater than 0.05 g, or if one or more wells appear to have much more liquid than the others, the washer failed the test.

If the test fails once, troubleshoot as follows:

- If the problem appears to be related to particular wells, clean those aspiration tubes: [Clean the Aspirate and Dispense Tubes on page 84](#). When finished, retry the test.
- Failure may occur when a microplate other than the recommended 24-well Corning 3524 plate is used. Modify the aspirate height (Z offset) or other parameters to accommodate the different plate geometry. After modifying the protocol, retry the test using a new microplate.
- Review possible causes of poor aspiration in the Troubleshooting section : See [Fluid Aspiration on page 146](#).

If the test fails a second time: contact BioTek TAC for assistance.

Create Qualification Protocols for 4 Well Manifold

To test the 4 Well manifold, you must create your own protocols. Follow these guidelines:

1. Select **Protocol** at the main menu.
2. Select **Create**.
3. Enter a unique name for the new protocol: for example: **4-Well accuracy_qc_test** and **4-Well residual_qc_test**.
4. Set the **Plate Type** to **24** and press **Save**.
5. Press **Add** and select the type of action to perform.
6. Define the parameters as shown below and **Save** the protocols:

4 Well Manifold Test Parameters

Evacuation Efficiency Test	Residual QC Test	
Aspirate Height: Z Offset	13 steps	1.65 mm
Y Offset Position	-90	4.11 mm
Aspirate Travel Rate	1	5.0 mm/sec
Aspirate Delay	2000 msec	
Secondary Aspirate	No	

Dispense Precision Test	Accuracy QC Test
Dispense Volume	1120 μ L/well
Dispense Flow Rate	5
Dispense Height: Z Offset	180 steps (22.87 mm)
Y Offset	00
Prime Before Start	Yes
Prime volume and flow rate	5 mL at rate 5

Dispense Precision Test

for 8-, 8s-, and 12 Well Manifolds

Washer Serial Number:	
Valve Used:	or N/A

Calculations	
Standard Deviation: (calculate using spreadsheet program)	
Mean OD: (sum of all wells ÷ 96)	
% Coefficient of Variation: ((Standard Deviation ÷ Mean OD) x 100)	
%CV ≤ 3.0	Pass Fail

Date:	
Performed By:	
If required, Reviewed/Approved By:	

Evacuation Efficiency Test

for 8-, 8s-, 12 Well Manifolds

Washer Serial Number:	
------------------------------	--

Test Results	
Total Residual Weight:	grams
Verification that wells are consistent in appearance:	Pass Fail
Mean Residual Weight (Total Residual Weight ÷ 96):	grams
Mean Residual Weight: ≤ 0.002 g	Pass Fail

Date:	
Performed By:	
If required, Reviewed/Approved By:	

Annual Buffer Switching Module Test

*for 8-, 8s- and 12 Well Manifolds
with Buffer Switching (Annual OQ only)*

Washer Serial Number:

Calculations for Valves A-D					
	Total Dispense Weight	28.8 g \pm 10%			
Valve A	grams	Pass	Fail	N/A	
Valve B	grams	Pass	Fail	N/A	
Valve C	grams	Pass	Fail	N/A	
Valve D	grams	Pass	Fail	N/A	

Date:	<input type="text"/>
Performed By:	<input type="text"/>
If required, Reviewed/Approved By:	<input type="text"/>

Dispense Precision Test

for 2x8 Well Manifolds

Washer Serial Number:	
Valve Used:	or N/A

Calculations	
Standard Deviation: (calculate using spreadsheet program)	
Mean OD: (sum of all wells ÷ 96)	
% Coefficient of Variation: ((Standard Deviation ÷ Mean OD) x 100)	
%CV ≤ 4.0	Pass Fail

Date:	
Performed By:	
If required, Reviewed/Approved By:	

Evacuation Efficiency Test

for 2x8 Well Manifolds

Washer Serial Number:	
------------------------------	--

Test Results	
Total Residual Weight:	grams
Verification that wells are consistent in appearance:	Pass Fail
Mean Residual Weight (Total Residual Weight ÷ 96):	grams
Mean Residual Weight: ≤ 0.004 g	Pass Fail

Date:	
Performed By:	
If required, Reviewed/Approved By:	

Dispense Precision Test

for 4 Well Manifolds

Washer Serial Number:	
Valve Used:	or N/A

Calculations	
Standard Deviation: (calculate using spreadsheet program)	
Mean OD: (sum of all wells ÷ 24)	
% Coefficient of Variation: ((Standard Deviation ÷ Mean OD) x 100)	
%CV ≤ 4.0	Pass Fail

Date:	
Performed By:	
If required, Reviewed/Approved By:	

Evacuation Efficiency Test

for 4 Well Manifolds

Washer Serial Number:	
------------------------------	--

Test Results	
Total Residual Weight:	grams
Verification that wells are consistent in appearance:	Pass Fail
Mean Residual Weight (Total Residual Weight ÷ 24):	grams
Mean Residual Weight: ≤ 0.05 g	Pass Fail

Date:	
Performed By:	
If required, Reviewed/Approved By:	

Vacuum Filtration Evacuation Efficiency Test

for 96-Well Filter Plates

Model:	50 TS/8F or 50 TS/8MF
Washer Serial Number:	

Test Results	
Verification that wells are consistent in appearance:	Pass Fail
Residual Weight:	grams
Residual Weight: ≤ 1.2 g	Pass Fail

Date:	
Performed By:	
If required, Reviewed/Approved By:	

Dispense Precision Test

for 8,16 Well Manifolds

Washer Serial Number:	
Valve Used:	or N/A

Calculations	
Standard Deviation: (calculate using spreadsheet program)	
Mean OD: (sum of all wells ÷ 384)	
% Coefficient of Variation: ((Standard Deviation ÷ Mean OD) x 100)	
%CV <= ≤ 4.0	Pass Fail

Date:	
Performed By:	
If required, Reviewed/Approved By:	

Evacuation Efficiency Test

for the 8,16 Well Manifold

Washer Serial Number:	
------------------------------	--

Test Results	
Total Residual Weight:	grams
Verification that wells are consistent in appearance:	Pass Fail
Mean Residual Weight (Total Resid. Weight ÷ 384):	grams
Mean Residual Weight ≤ 0.004 g	Pass Fail

Date:	
Performed By:	
If required, Reviewed/Approved By:	

Annual Buffer Switching Module Test

*for the 8,16 Well Manifold
with Buffer Switching (Annual OQ only)*

Washer Serial Number:

Calculations for Valves A-D					
	Total Dispense Weight	38.4 g \pm 10%			
Valve A	grams	Pass	Fail	N/A	
Valve B	grams	Pass	Fail	N/A	
Valve C	grams	Pass	Fail	N/A	
Valve D	grams	Pass	Fail	N/A	

Date:	<input type="text"/>
Performed By:	<input type="text"/>
If required, Reviewed/Approved By:	<input type="text"/>

Troubleshooting

This chapter provides detailed installation instructions.

Troubleshooting Overview	134
Error Codes	134
Fatal Errors	135
General Errors	136
Troubleshooting Charts	146

Troubleshooting Overview

Every effort has been made to ensure that the 50 TS is extremely reliable and easy to use. Nevertheless, you could experience problems with the washer hardware, software, and/or accessories. This chapter offers information to help resolve these problems.

- See [Error Codes below](#)
- The [Troubleshooting Checklist below](#) is a concise summary of possible causes for many potential problems during operation of the washer.
- The [Troubleshooting Charts on page 146](#) provide detailed lists of problems, their possible causes, and possible solutions.

Troubleshooting Checklist

Periodic inspection of the washer, tubing, and bottles for the possible causes listed below may help to eliminate many of the problems listed on the following pages.

Check for the following:	
✓	Loose or incorrect connections of power cord, power supply, waste and supply tubing and fittings.
✓	Incomplete or incorrect installation of manifold and carrier, attachment of mist shield, or placement of microplate/strips in carrier.
✓	Accumulation of residue on carrier or inside aspirate/dispense tubes, waste/supply bottles and tubing, manifold, inlet/outlet fittings, optional in-line vacuum filter, or optional pump muffler.
✓	Worn tubing, O-rings, inlet or outlet fittings, manifold gaskets or vacuum seals.
✓	Kinked or bent aspirate/dispense tubes or waste/supply tubing.

Error Codes

An error code is displayed on the 50 TS as a four-digit identifier. The first character is either 0, 1, 2, or A.

- 0 or 1 denote a non-critical ("General") error, which means that the instrument will still respond to touchscreen input. [General Errors on the next page.](#)
- "A" denotes a more serious error: [Fatal Errors](#). Write down the error code and restart the 50 TS (turn it off and then on). Upon restarting the washer, you should be able to use the washer. If not, contact BioTek TAC: [See Contacting the Technical Assistance Center on page 3.](#)

Fatal Errors

Fatal errors indicate conditions that require immediate attention. If a fatal error is displayed, contact BioTek's Technical Assistance Center for instructions: [See Contact Information on page vii.](#)

Error	Code	Cause
TCB_NOT_AVAIL_ERR	A100	Task control block not available.
READ_NOT_AVAIL_ERR	A200	Washer function already in use.
NOT_AVAIL_ERR	A300	Manifold motor not available.
	A301	Carrier motor not available.
	A302	Syringe motor not available.
	A304	Software timer not available.
	A305	Display not available.
	A306	Quick flash memory not available.
CHECKSUM_ERR	A400	Failed code checksum test on power-up; memory corruption.
POWER_ERR	A500	Power dropped below safe level.
QFLASH_TIMEOUT_ERR	A600	Quick flash memory configuration timed out. Memory corruption; contact TAC.

Error	Code	Cause
QFLASH_ERR	A700	Quick flash memory read did not match write. Memory corruption; contact TAC.
HEAP_CORRUPTED_ERR	A900	Memory manager corruption detected. Contact TAC.
Note: Unavailability of a motor, software timer, display or quick flash memory (NOT_AVAIL_ERR) may be caused by loose cables.		

General Errors

General errors indicate non-fatal conditions that require attention. If an error is displayed, refer to the [See Troubleshooting Overview on page 134](#). Contact BioTek's Technical Assistance Center for further assistance.

Error	Code	Cause	What to Do
ABORT_ERR	0100	Wash function aborted.	Restart instrument if this message is unexpected.
NO_SENSOR_ERR	0200, 0210, 0220, 0230	Manifold motor couldn't find optical sensor.	Run self test. If error reoccurs, contact BioTek TAC.
	0201, 0211, 0221, 0231	Carrier motor couldn't find optical sensor.	Clean the plate carrier and rails using mild detergent and hot water, 70% isopropyl alcohol or ethanol. Restart the instrument. If the error occurs again, contact BioTek TAC.
	0202, 0212	Syringe motor couldn't find optical sensor.	Run self test. If error reoccurs, contact BioTek TAC.
Motor Interlock error	0300	Z axis motor interlock safety	Run self test. If error

Error	Code	Cause	What to Do
		switch open.	reoccurs, contact BioTek TAC.
	0301	Y axis/carrier motor interlock safety switch open.	
MOTOR_VERIFY_ERR	0400	Manifold motor failed positional verify.	Service Only. Contact BioTek TAC.
	0401	Carrier motor failed positional verify.	Service Only. Contact BioTek TAC.
	0402	Syringe motor failed positional verify.	Service Only. Contact BioTek TAC.
MOTOR_IN_USE_ERROR	0600 0601 0602	Z Axis motor currently in use Carrier/Y Axis in use Syringe motor in use	Run self test. If error reoccurs, contact BioTek TAC.
MOTOR_NOT_FOUND_ERROR	0700 - 070f	Invalid motor number specified	Service Only. Contact BioTek TAC.
INVALID_PROFILE_ERROR	0800	Invalid profile selected	Try a different dispense, primer, or travel rate. If error reoccurs, contact BioTek TAC.
INVALID_PLATE_TYPE_ERR	0900	Invalid plate type selected	The currently selected plate type is not supported with the currently installed or requested manifold. If this is not the case, contact BioTek TAC.
SYR_VOLUME_TOO_LARGE	0A00	Syringe volume too large.	Protocol may have been written for a different type of dispense manifold. Make sure the Instrument Settings represent the installed hardware. Modify the protocol to match.
AUTOCAL_JIG_ERR	0B00	Did not find edge of jig. Invalid manifold for calibration.	Jig is already touching the sensor before the move starts. Make sure the jig is fully seated in

Error	Code	Cause	What to Do
			the carrier.
INVALID_BUFFER_ERR	0C00	Invalid buffer selected.	If using the buffer switching module, choose A, B or C.
CAL_CHECKSUM_ERR	0D00	Failed calibration checksum test.	The touchscreen calibration data is corrupt. Contact BioTek TAC.
DISPENSE_RATE_ERR	0E00	Dispense rate is invalid for manifold type.	Select a different dispense rate or volume, one that is valid for the manifold type (see Dispense Volume Invalid for Manifold Type 0F00 Error on page 153).
DISPENSE_VOLUME_ERR	0F00	Dispense volume invalid for manifold type.	Select a different dispense rate or volume, one that is valid for the manifold type (see Dispense Volume Invalid for Manifold Type 0F00 Error on page 153).
Boot Code Errors	1001-1010	see table below	Run self test. If error reoccurs, contact BioTek TAC.
Note: Calibration errors (AUTOCAL_JIG_ERROR; MANIFOLD_AUTOCAL_ERR; CAL_CHECKSUM_ERR) will normally be displayed only during calibration or repair of the instrument by BioTek TAC.			

Boot Code Errors

BOOT_POWERUP_CHECKSUM_FAIL	1001	Bootcode power-up checksum test failed
BOOT_ERROR_UNKNOWN	1002	Unknown error in bootcode
BOOT_PAGE_PROGRAM_ERROR	1003	Bootcode page program error
BOOT_BLOCK_SIZE_ERR	1004	Bootcode block size error (not 256)
BOOT_INVALID_SIGNATURE	1005	Invalid processor signature (not 1280,1281,2560,2561)

BOOT_MEMORY_EXCEEDED	1006	Bootcode memory exceeded
BOOT_INVALID_SLAVE_PORT	1007	Invalid slave port
BOOT_INVALID_SLAVE_RESPONSE	1008	Invalid response from slave
BOOT_INVALID_PROCESSOR	1009	Invalid processor detected
BOOT_DOWNLOAD_CHECKSUM_ERR	1010	Checksum error downloading basecode

Error	Code	Cause	What to Do
UI_STACK_TEST_ERROR	1260	A stack memory corruption error occurred with the UI processor.	Service Only. Contact BioTek TAC.
MC_STACK_TEST_ERROR	1261	A stack memory corruption error occurred with the MC processor.	Service Only. Contact BioTek TAC.
AUTOCAL_ABORT_ERR	1400	Autocal of washer was aborted.	Service Only. Rerun autocal.
INVALID_WASH_CYCLES	1401	Invalid number of wash cycles	Edit protocol to specify a valid wash cycle value.
INVALID_WASH_FORMAT	1402	Invalid wash format	Make sure "Wash Format" mode is defined as either Plate or Strip.
INVALID_FLOW_RATE	1403	Invalid dispense or prime flow rate	Select a dispense rate or volume that is valid for the manifold type (see Dispense Volume Invalid for Manifold Type 0F00 Error on page 153).
INVALID_MANIFOLD_TYPE	1404	Invalid manifold type	Check instrument configuration. Specify a manifold supported by the instrument model.
INVALID_STEP_TYPE	1405	Invalid protocol step type	Retry. If errors persist, contact BioTek TAC.
INVALID_CARRIER_TYPE	1406	Invalid carrier type	Check instrument configuration. Specify a plate carrier supported by the instrument model.
MANIFOLD_AND_PLATE_INCOMPATIBLE	1407	Manifold and plate type are incompatible with each other	Protocol may have been written for a different manifold. Make sure the Instrument Settings represent the installed

Error	Code	Cause	What to Do
INCOMPATIBLE_HW_ERROR	1408	Run-time manifold, carrier or plate type incompatibility	hardware. Modify the protocol to match.
CARRIER_AND_MANIFOLD_INCOMPATIBLE	1409	Carrier and manifold type are incompatible with each other	
CARRIER_AND_PLATE_INCOMPATIBLE	1410	Carrier and plate type are incompatible with each other	
AUTOPRIME_IN_PROGRESS_ERROR	1411	LHC displays this error when it receives a request/command when AutoPrime is in progress. AutoPrime is cancelled and a self-check is performed.	After self-check, the request can be resent, if necessary.
AUTOPRIME_ABORTING_ERROR	1412	The AutoPrime routine was stopping when another request was received.	After self-check, the request can be resent, if necessary.
AUTOPRIME_VALUE_OUT_OF_RANGE	1413	One of the AutoPrime values is out of range	Make sure AutoPrime values are within range: volume must be valid for the flow rate.
ASP_AND_FINAL_ASP_MISMATCH	1414	Final aspirate parameters are inconsistent with wash aspirate parameters.	Edit "Final Aspirate" parameters to match wash cycle aspirate parameters or ignore error.
INVALID_Y_OFFSET	1415	Invalid Y offset value for plate/manifold type	Protocol may have been written for a different manifold. Make sure the "Advanced Options" for the wash, dispense, aspirate steps are valid for the installed hardware.
INVALID_Z_OFFSET	1416	Invalid Z offset value	
INVALID_PROTOCOL_NAME	1417	Invalid protocol name	Shorten the name of the protocol.
BUFFER_SWITCHING_IS_REQUIRED	1418	The buffer switching module is required for multiple buffers	Protocol may have been written for an washer with buffer switching. Edit the protocol to use the same "buffer" in each step.
INVALID_SHAKE_SOAK_OPTIONS	1419	Invalid shake/soak options	Protocol may have been written for a different instrument. Edit the shake step(s) to select valid

Error	Code	Cause	What to Do
INVALID_SHAKE_INTENSITY	1420	Invalid shake intensity	parameters for soaking and shaking.
INVALID_SHAKE_DURATION	1421	Invalid shake duration	
INVALID_SOAK_DURATION	1422	Invalid soak duration	
INVALID_WASHER_ASP_DELAY	1424	Invalid aspirate delay or vacuum filtration delay value	Protocol may have been written for a different instrument. Edit wash or aspirate steps to select valid parameters.
INVALID_WASHER_ASP_TRAVEL_RATE	1425	Invalid aspirate travel rate value	
PROMPT_STEP_MISSING_PROMPT	1426	The prompt step is missing any text for the prompt	Enter at least one text character, as required for a Prompt step.
ODD_STRIP_COUNT_ENCOUNTERED	1427	Odd strip count found; need even count for 2x8 manifold	Two rows or strips are processed simultaneously with the 2x8 manifold. Choose an even number of strips.
TEXT_TOO_LONG	1428	Text string is too long	Shorten the text string.
INVALID_PLATE_TYPE_FOR_VF	1429	Invalid plate type selected for vacuum filtration operation.	Vacuum filtration is only supported with 96-well plates.
AUTOPRIME_CHECKSUM_ERR	1500	Checksum error with the autopriming data stored in eeprom memory	Service Only. Rerun autocal.
PROTOCOL_CNFG_CHECKSUM_ERR	1550	Checksum error with the protocol data stored in eeprom memory	Service Only. Contact BioTek TAC.
QUICK_CNFG_CHECKSUM_ERR	1551	Checksum error with the Quick data stored in eeprom memory	Exit the Quick menu and try again.
PROT_NO_STEP_SPACE	1600	Generic no SPI memory space left for storing anymore manifold steps	Edit protocols to use 15 or fewer steps.
PROT_NO_STEP_SPACE_MWASH	1606	No SPI memory space left for storing anymore manifold wash steps	Delete unused protocols containing Wash steps to free up space. Alternatively, use LHC to re-map protocol memory: Manage Memory .
PROT_NO_STEP_SPACE_MASP	1607	No SPI memory space left for storing anymore manifold aspirate steps	Delete unused protocols containing Aspirate steps to free up space.

Error	Code	Cause	What to Do
			Alternatively, use LHC to re-map protocol memory: Manage Memory .
PROT_NO_STEP_SPACE_MDISP	1608	No SPI memory space left for storing anymore manifold dispense steps	Delete unused protocols containing Dispense steps to free up space. Alternatively, use LHC to re-map protocol memory: Manage Memory .
PROT_NO_STEP_SPACE_MPRIME	1609	No SPI memory space left for storing anymore manifold prime steps	Delete unused protocols containing Prime steps to free up space. Alternatively, use LHC to re-map protocol memory: Manage Memory .
PROT_NO_STEP_SPACE_SHAKE	160B	No SPI memory space left for storing anymore shake/soak steps	Delete unused protocols containing Shake/Soak steps to free up space. Alternatively, use LHC to re-map protocol memory: Manage Memory .
PROT_NO_STEP_SPACE_PROMPT	160C	No SPI memory space left for storing anymore prompt steps	Delete unused protocols containing Prompt steps to free up space. Alternatively, use LHC to re-map protocol memory: Manage Memory .
PROT_NO_STEP_TYPE	160D	No step type provided	Make sure all steps are valid for current hardware configuration.
UI_SPI_CNFG_CHECKSUM_ERR	1700	Checksum error with the SPI data stored in eeprom memory	Service Only. Contact BioTek TAC.
INSTR_CNFG_CHECKSUM_ERR	1800	Checksum error with the instrument configuration data stored in eeprom memory	Service Only. Contact BioTek TAC.

Error	Code	Cause	What to Do
ASPIRATE_POS_ERR	1A00	Carrier aspirate position is out-of-range for present manifold.	Protocol may have been written for a different manifold or plate type. Make sure the Instrument Settings represent the

Error	Code	Cause	What to Do
DISPENSE_POS_ERR	1B00	Carrier dispense position is out-of-range for present manifold.	installed hardware. Modify the protocol to match.
AUTOCAL_CHECKSUM_ERR	1E00	Failed autocal checksum. Autocal has not been run.	
CHECK_FLUID_START_ERR	2800	Liquid Level Alert only. A supply bottle's fluid level has dropped below 400/450 mL and/or the waste bottle's fluid level has risen above 1400/1450 mL. Or, the Liquid Level Alert option is enabled but the select box is not properly connected to the washer.	Fill the supply bottle; or empty the waste bottle, as applicable. Alternatively, if needed, reinstall the liquid level alert components or make sure its cable is properly connected to the washer.
CHECK_FLUID_END_ERR	2900		
INCOMPATIBLE_HW_ERR	2A00	Both the vacuum filtration (bottom aspirate) and buffer switching features are enabled. This is not a valid hardware configuration.	Service Only. Contact BioTek TAC.
INVALID_VACUUM_FILTR_ERR	2A01	Vacuum filtration is invalid when using strip mode as the wash format	Perform protocol on entire plate, Do not select fewer strips at runtime.
PROGRAM_LOCKED	4000	Program locked so operation denied	"Copy" the protocol (to preserve the locked original), then, make changes to the protocol steps to customize the protocol for your own assays.
PROGRAM_BAD_CHECKSUM	4020	Bad checksum when reading protocol from eeprom	Service Only. Contact BioTek TAC.
PROGRAM_NOT_FOUND	4030	Program not found	Re-create lost protocol.
PROGRAM_NO_STORAGE_SPACE	4040	Cannot save program because no space available	Delete unused protocols to free up space. Consider using LHC to re-map protocol memory: Manage Memory .
PROGRAM_RUN_CANCELED	4050	Program run canceled by user	Rerun the protocol.
STEP_NOT_FOUND	4060	Cannot find step in SPI for the given link	Re-create the protocol.
DUPLICATE_PROTOCOL_	4070	Duplicate protocol name	Every protocol must have a

Error	Code	Cause	What to Do
NAME			unique name. Rename the protocol.
SC_NAK_ERROR	81n0	Communications NAK (n - channel type) *	Retry operation.
SC_TIMEOUT_ERROR	81n1	Timeout while waiting for serial message data (n - channel type) *	Retry operation.
SC_COM_BUSY_ERROR	81n2	Instrument busy and unable to process message (n - channel type) *	Restart instrument and retry operation.
SC_RX_BUF_OVERFLOW_ERROR	81n3	Receive buffer overflow error (n - channel type) *	Restart instrument and retry operation.
SC_CHECKSUM_ERROR	81n4	Checksum error (n - channel type) *	Service Only. Contact BioTek TAC.
SC_INVALID_STRUCT_TYPE	81n5	Invalid structure type in byMsgStructure header field (n - channel type) *	Service Only. Contact BioTek TAC.
SC_INVALID_DESTINATION	81n6	Invalid destination in byMsgDestination header field (n - channel type) *	Service Only. Contact BioTek TAC.
SC_OBJECT_NOT_SUPPORTED	81n7	Request object received not supported by instrument (n - channel type) *	Service Only. Contact BioTek TAC.
SC_MSG_BODY_SIZE_ERROR	81n8	Message Body size exceeds max limit (n - channel type) *	Service Only. Contact BioTek TAC.
SC_MAX_REQS_RUNNING_ERROR	81n9	Max number of requests currently running and cannot run the latest request (n - channel type) *	Restart instrument and retry operation.
SC_NO_REQS_RUNNING_ERROR	81nA	No request running when response request issued (n - channel type) *	Restart instrument and retry operation.
SC_RESP_NOT_READY_ERROR	81nC	Response for outstanding request not ready yet (n - channel type) *	Restart instrument and retry operation.
SC_INST_NOT_IN_PC_COMM_MODE	81nD	Instrument not in a mode to receive a PC message (n - channel type) *	Return to Home (Main Menu) and retry.
SC_REQ_PARAMS_NOT_VALID	81nE	One or more request parameters are not valid (n - channel type) *	Restart instrument and retry operation.
SC_COMMAND_OUT_	81nF	The command was received while	Return to Home (Main

Error	Code	Cause	What to Do
OF_CONTEXT		the software was in a state not ready to accept that command. (n - channel type) *	Menu) and retry.
DEV_NOT_AVAIL_ERR	A100 Å to A10f	Software device not available - A103 is a timer device in the UI processor, and A113 is a timer device in the MC processor.	Restart instrument and retry operation.
CODE_VERSION_ERR	A200	Version strings for multiple Processors do not match	Service Only. Contact BioTek TAC.
POWER_SUPPLY_ERR (+5v)	A301	+5v logic power supply level error	Service Only. Contact BioTek TAC.
POWER_SUPPLY_ERR (+24v)	A302	+24v system/motor power supply level error	Service Only. Contact BioTek TAC.
DISPLAY_IN_USE	A500	Multiple tasks attempted to use display simultaneously	Restart instrument and retry operation.
SERIAL_EEPROM_ERR	A600	Chip ID 0..n serial eeprom access error	Service Only. Contact BioTek TAC.
MTR_TRUNCATION_ERR	A700	Motor move steps are being truncated based on the profile	Service Only. Contact BioTek TAC.
MTR_PROFILE_ERR	AA30	Motor resolution cannot land on the proper index	Service Only. Contact BioTek TAC.
STACK_OVERFLOW_ERR	AD00	Stack corruption detected	Service Only. Contact BioTek TAC.

* - The channel type refers to the source-destination communication channel for the message that had the error. The source-destination channel types are as follows:

- 0 - Communication was occurring between computer (PC) and instrument
- 1 - Communication was occurring between the two internal processors of the instrument (i.e. User Interface processor and Motor Controller processor)
- 2 - Communication was occurring between the instrument and a BioStack (if supported)

For example, an SC_TIMEOUT_ERROR (81n1) between the PC and instrument would get an 8101 error; between the two Internal processors would get an 8111 error; and between the instrument and the BioStack would get an 8121 error, if applicable.

Troubleshooting Charts

Washer Start-Up

Problem	Possible Cause	Possible Solution
Display (LCD) not on.	Power cord not plugged in or loose.	Check the power connection.
Syringe, carrier, or manifold position error.	Manifold or carrier is being obstructed.	Remove any obstruction. Make sure the manifold and carrier are properly installed.
	Motor, sensor, or electrical problem.	Turn the washer off, wait at least 15 seconds, then turn it back on. If it fails the self-test, the washer will beep and display an error code. Press the STOP button to stop the beep, and look up the code in Error Codes .
	Misaligned carrier or manifold.	Contact BioTek TAC.

Fluid Aspiration

Problem	Possible Cause	Possible Solution
Poor or uneven aspiration.	Insufficient or no vacuum.	If the optional inline vacuum filter or optional pump muffler has been installed, the filter or muffler may need to be replaced.
		Firmly seat the waste bottle stopper. Ensure the tubing is connected properly.
		Check all external tubing for kinks or accumulations of residue.

Problem	Possible Cause	Possible Solution
		When aspiration begins, you should hear the vacuum pump turn on. If the pump does not turn on, contact BioTek TAC.
	Insufficient or no vacuum.	When the vacuum pump turns on, remove the vacuum tubing from the back of the washer while the pump is on. Put your finger over the port; if there is no vacuum, contact BioTek TAC.
	Clogged aspirate tubes on the washer manifold.	Remove and clean the manifold. See Clean the Aspirate and Dispense Tubes on page 84.
	Microplate aspiration height adjustment too high or too low.	Change the defined aspiration height.
	Aspirate tubes not properly positioned horizontally in wells.	If none of the tubes are bent, try adjusting the specified horizontal aspirate position.
	Microplate not level in carrier or strips not level in holder.	Reseat the microplate in the carrier or the strips in their holder.
		Make sure the carrier is clean.
		Try a different microplate or strip holder. If the problem is unresolved, the carrier may have to be realigned. Contact BioTek TAC.
	Movement rails misaligned.	Contact BioTek TAC.
	Clogged vacuum filter	The optional in-line vacuum filter or optional pump muffler may need to be replaced.

Problem	Possible Cause	Possible Solution
	or pump muffler.	
Too much residual left in microwells after aspiration.	Wash protocol requires optimization for the plate type used.	To minimize the residuals, add a second or Crosswise Aspiration step to the protocol.
	Waste bottle stopper not properly sealed or fittings not properly connected.	Firmly seat the waste bottle stopper. Make sure the tubing is connected properly. Ensure that the fittings are properly connected to the manifold.
		Check the fit of the gasket (rubber top seal) on the manifold (Clean the Aspirate and Dispense Tubes on page 84). If the fit is loose, contact BioTek TAC.
	Manifold out of alignment or not moving freely.	Check for obstructions and make sure the manifold is properly installed. If no obstructions are found and the manifold is correctly installed, contact BioTek TAC.
	Microplate not level in carrier or strips not level in holder.	Reseat the microplate in the carrier or the strips in their holder.
		Ensure that the carrier is clean.
		Try a different microplate or strip holder. If the problem is unresolved, the carrier may have to be realigned. Contact BioTek TAC.
	Using 16-channel manifold to wash 8-well strips with	The 16-channel manifold may not be compatible with all 96-well format strips and plates. This manifold uses two aspirating tubes for each well, and it may be difficult for these tubes to reach the bottom of wells that are not flat.

Problem	Possible Cause	Possible Solution
	round or "V" bottoms.	
	Aspirate tubes are bent.	Gently attempt to straighten the tubes using your fingers. If they remain bent, contact BioTek TAC.
Vacuum Filtration problems		
Poor or uneven evacuation with vacuum filtration – filter plate assays.	Clogged filters in filter-bottom plates.	If the plate is old or has been used more than once, the filter paper may be dirty, resulting in poor aspiration. Use a new plate.
		A combination of thick solution and high vacuum level may cause clogging in some filter-bottom plates. Try a lower vacuum level or larger pore size filter plates.
		Vacuum filtration times are too long, causing beads to lodge in the bottom of the wells. Try shorter aspiration times initially (e.g., 5 seconds). Gradually increase the aspiration time until suitable evacuation is achieved.
	Vent plugs are clogged.	Observe the vent port and vent plugs. Soak the plugs and the carrier in hot soapy water to eliminate clogs.
Poor or uneven evacuation with vacuum filtration – filter plate assays.	Vacuum lines not connected or incorrectly connected.	Ensure the vacuum lines to the manifold and aspiration carrier are connected. Note: if the lines are reversed, the top and bottom functions will be reversed. If this is the case, reconnect the lines correctly.
	Seal did not form.	If the filter-bottom plate is not seated correctly in the aspiration carrier, a seal will not form, resulting in no vacuum. Reposition the plate in the carrier. Also, check for residue on the carrier or carrier

Problem	Possible Cause	Possible Solution
		transport rails, and clean them, if necessary.
		Check the rubber gasket on the aspiration carrier. If it is worn, there may be air leaks, resulting in a poor seal. If this is the case, replace the gasket.
		If all 96 wells do not contain fluid, a seal will not form. Aspirate full plates only.
	Incorrect plate size.	If the filter-bottom plate is the wrong size, a seal will not form, resulting in no vacuum. Try a plate with a different filter pore size.
	Vacuum reservoir bottle is full.	If the vacuum reservoir bottle is full, the vacuum pump will draw fluid into the in-line filter or pump muffler and lower the vacuum level. A full bottle will also result in fluid being drawn into the pump, causing the vacuum level to drop. Empty the bottle.
Vacuum filtration protocols are missing.	Predefined and custom vacuum filtration protocols are not displaying for run or edit.	Check the manifold setting: Instrument>Manifold and make sure it is set to 8 or 8s for vacuum filtration assays.
<p>Note: Monthly performance of the Evacuation Efficiency test is recommended to verify that the residual volume per well after evacuation (aspiration) meets the specified criteria. Which Tests to Perform? on page 103</p>		

Fluid Delivery

Problem	Possible Cause	Possible Solution
Unable to dispense fluid.	Inlet tube not connected at manifold or at bottle.	Check all tubing. See Connecting the Tubes and Bottles on page 19 .

Problem	Possible Cause	Possible Solution
	Supply tube inside the supply bottle is kinked or disconnected.	Straighten or connect supply tube. Cut the tubing as shown at Optimize Performance on page 44 .
	Clogged dispense tubes on the washer manifold.	Remove and clean the manifold. Clean the Manifold on page 83 .
	Check-valve flow direction is incorrect.	Make sure the flow direction arrow of the check valves matches the actual flow direction.
	Check valves are stuck closed.	Clean or replace the check valves. See Replace (or Clean) the Check Valves on page 94 .
	Dispense tube not plugged into syringe pump.	Connect the tube from the supply vessel into the top connector of syringe pump.
	No wash or rinse fluid.	Fill bottles with appropriate fluid.
	System not primed.	Run a Prime program using 60 mL.
	Faulty syringe pump.	Contact BioTek TAC.
Plate overfills (floods).	Dispense height too high. The aspirate tubes are too many steps above the microwells to prevent overflow.	Change the Dispense Height in the protocol. Make sure the manifold setting is correct (Instrument>Config).
	Aspirate tubes hit bottom of trough during Prime or Maintenance.	Contact BioTek TAC.
	Fittings to manifold not connected.	Reconnect fittings.
	Optional in-line vacuum filter or optional pump muffler plugged.	Replace or remove the filter or pump muffler.

Problem	Possible Cause	Possible Solution
	Rubber stopper on waste bottle is loose.	Push rubber stopper into waste bottle to create a better seal.
	Dispense rate too fast for volume selected.	Use slower dispense rate or lower volume.
	Insufficient or no vacuum.	Firmly seat the waste bottle stopper. Make sure tubing is connected properly.
		Check all external tubing for kinks or clogs.
		The inline vacuum filter or the pump muffler may need to be replaced.
		When the run begins, you should be able to hear the vacuum pump turn on. If not, contact BioTek TAC.
		If the vacuum pump is turning on, remove the vacuum tubing from the back of the washer while the vacuum pump is on. Put your finger over the port; if there is no vacuum, contact BioTek TAC.
Washers with Buffer Switching: unable to dispense.	Solenoid valve not opening.	Contact BioTek TAC.
	Solenoid valve tubing disconnected, or wrong solenoid inlet connected.	Reconnect or redirect tubing.
Uneven dispensing of fluid; wells not filled.	Manifold or tubing not adequately primed.	Run a Prime program using 60 mL.

Problem	Possible Cause	Possible Solution
	Dispense flow rate too low.	Select a higher flow rate.
	Clogged dispense tubes on the washer manifold.	Remove and clean the manifold. Clean the Manifold on page 83.
	Microplate aspiration height adjustment too high or too low.	Change the Aspiration Height in the protocol.
Dripping dispense tubes.	Dispense tubing routed incorrectly.	The supply bottle tube must enter the syringe at the bottom. Also, check for holes in the manifold gasket.
<p>Note: Monthly performance of the Dispense Precision test is recommended to measure the variability of volumes dispensed from tube to tube across the manifold.</p>		

Dispense Volume Invalid for Manifold Type (0F00 Error)

An 0F00 error at runtime indicates a validation error in the protocol, and that the current dispense volume/flow rate combination is invalid for the installed manifold. The 50 TS does not validate this parameter during protocol creation, only at runtime.

To fix the error, edit the protocol: change the Dispense Volume or Flow Rate so that they are compatible with your manifold type.

A valid flow rate is dependent on the dispense volume and manifold type:

Flow Rate	Dispense Volume Range (µL/well) by Manifold Type					
	8 and 8s	12	2x8	4	8,16	
	96-well	96-well	96-well	24-well	96-well	384-well
1	50-3000	50-3000	25-3000	100-3000	50-3000	25-3000
2	50-3000	50-3000	25-3000	100-3000	50-3000	25-3000
3	50-3000	50-3000	32-3000	100-3000	50-3000	25-3000
4	50-3000	50-3000	53-3000	100-3000	55-3000	28-3000

Flow Rate	Dispense Volume Range ($\mu\text{L}/\text{well}$) by Manifold Type					
	8 and 8s	12	2x8	4	8,16	
5	50-3000	60-3000	75-3000	100-3000	60-3000	30-3000
6	50-3000	70-1100	not valid	not valid	90-3000	45-3000
7	55-3000	70-1100	not valid	not valid	100-3000	50-3000
8	100-3000	not valid	not valid	not valid	106-3000	53-3000
9	110-3000	not valid	not valid	not valid	110-3000	55-3000

For example, if your protocol currently specifies a Volume of 1500 and Flow Rate of 8, and the 8-channel manifold is installed, reduce the Flow Rate to 7 or dispense a smaller volume ($<1100 \mu\text{L}$).

Fluid Leakage

Problem	Possible Cause	Possible Solution
Dripping dispense tubes.	Dispense tubing routed incorrectly.	Make sure the supply bottle tube is connected to the syringe's bottom port.
Fluid leaking from manifold.	Defective seals.	If 8, 8s, 2x8, 4, 12 Well manifold, replace manifold gasket. If 8,16 Well manifold, replace plugs and O-ring on 'T' plug.
		Replace o-rings on washer manifold inlet fittings.
		Contact BioTek TAC.
	Teflon® sleeves are defective or missing.	Reposition sleeves.
		Contact BioTek TAC.
	Check valves	Clean or replace check valves Clean the Check

Problem	Possible Cause	Possible Solution
	are leaking.	Valves on page 94.
	Aspirate tubes only: vacuum too low.	Check waste connector tubes, and make sure they are properly connected to the manifold.
		Check vacuum filter for clogging, replace if necessary.
		Push rubber stopper into waste bottle to create a better seal.
		Use a slower Aspiration Travel Rate in the protocol.
Fluid leaking from underneath the instrument.	Defective tubing connector or inlet tubing.	Contact BioTek TAC.
	Leaking syringe seal.	Contact BioTek TAC.
	Defective syringe piston.	Contact BioTek TAC.
Fluid leaking from external tubing connector.	Defective connector.	Replace connector.
	Worn tubing.	Replace tubing.
	Worn seal (inlet or vacuum fitting).	Replace filter or seal.

Carrier Movement

Problem	Possible Cause	Possible Solution
Standard Microplate Carrier		
Aspirate tubes not entering wells correctly.	Aspirate tube(s) bent.	Push the stylus needle into the tube and then gently attempt to straighten the tube using your fingers. If it remains bent, contact BioTek TAC.
	Microplate not properly seated or strips not level.	Reseat the microplate in the carrier or the strips in the holder. Make sure the plate is distributed squarely to the front edge of the carrier.
		Make sure the carrier is clean.
	Horizontal aspirate position (Y-axis) is set too wide for a movement.	Change the horizontal aspirate position (Y-axis) value in the protocol.
	Manifold tilted.	Check tubing for twists; add manifold screws (PN 12174).
Vacuum Filtration Carrier (8F/8MF models)		
Vacuum Filtration carrier loses steps during run.	Insufficient flex room for tubing between carrier and washer.	Pushing the washer up against a wall or other obstruction may result in insufficient flex room for the tubing during carrier movement. Reposition the washer and/or tubing to allow enough room.

Washer Manifold Movement

Problem	Possible Cause	Possible Solution
Manifold position error.	Manifold movement is blocked.	Check orientation of microplate; A1 should be in the right rear corner of the plate carrier as you face the front of the instrument.
		Check for and remove any obstructions.
		Ensure that the manifold is resting on the manifold support bracket.
		Contact BioTek TAC.

Syringe Drive Movement

Problem	Possible Cause	Possible Solution
Syringe drive gives movement errors.	Check valves incorrectly mounted.	Remount check valves.
	Obstructions in syringe path.	Remove any obstructions.

Microplate Scratches

Problem	Possible Cause	Possible Solution
Scratches on microplate bottom.	Microplate dispense or aspiration height adjustment too low.	Increase the Dispense or Aspiration Height in the protocol.
	Microplate not properly seated or strips not level.	Reseat microplate in carrier or strips in holder.

Problem	Possible Cause	Possible Solution
		Make sure the carrier is clean.
		Try a different microplate or strip holder. If the problem is unresolved, the carrier may have to be realigned. Contact BioTek TAC.

Index

8		C	
8F models.....	15, 28, 60, 77	Carrier	
8M models.....	15, 28, 58	variations of.....	14
8MF models.....	15, 28, 58, 60, 77	Check valves	
8MV models.....	28	replace.....	94
		Chemical compatibility.....	71
A		Clean	
Accessories listing.....	6	exterior.....	82
Add steps to a protocol.....	50	periodic maintenance.....	80
Air bubbles in tubing.....	44	Copy.....	50
Alcohol, Isopropyl.....	88	Copy a protocol.....	64
Applications		Crosswise Aspiration.....	56
magnetic bead.....	58	Cycles	
vacuum filtration.....	58	specify number of wash cycles..	50
Aspirate		D	
Crosswise.....	56	DAY_RINSE.....	72-73, 77
Delay.....	56	Dead volume.....	38, 75
Height.....	55	Decontaminate.....	77
problems.....	148	external surfaces.....	89
Rate.....	56	process described.....	87
AutoPrime.....	40, 67, 78	required supplies.....	88
AutoPrime Interval.....	40	tubing and manifold.....	90
		vacuum filtration carrier.....	90
B		Decontamination	
Best practices.....	44	prime programs.....	74
Biomagnetic separation		protein removal.....	80
assays.....	58	solution.....	88
carrier.....	15, 28	Disinfectant.....	88
Bleach.....	88	Dispense	
Bottom Wash.....	54	Flow Rate.....	53
Disp Height.....	54	Height.....	53
Disp Volume.....	54	Horizontal position.....	54
Flow Rate.....	54	problem, error.....	150
Bovine serum albumin.....	79, 88	Volume.....	53
BSA.....	70, 79	Dripping tubes.....	154

E			
<hr/>			
Edit steps in a protocol.....	50	Liquid test	
ELISA.....	41	protocol parameters.....	
Enzyme-Active Detergent.....	80	107	
Error codes.....	134	Liquid test worksheet.....	
Fatal.....	135	123-124, 126	
General.....	136	Long_Shutdown.....	
Evacuation efficiency test.....	107	74, 77, 92	
F			
<hr/>			
Filter		M	
plates, vacuum filtration.....	60	<hr/>	
vacuum line.....	23	Magnetic Bead Assays.....	58
Final Aspir Delay.....	57	Maintenance	
Final Aspiration.....	56	clean exterior.....	82
Flow problem.....	150	overnight.....	78
Flow Rate.....	53	overview.....	70
Fluid		preventive.....	80
too much left after wash.....	146	programs.....	73
Fluid leaking.....	154	schedule.....	72
Fluid not dispensing.....	150	vacuum filtration.....	77
Fungi Growth.....	79	Manifold	
H		clean tubes.....	84
<hr/>		cleaning.....	83
Horizontal Aspir Pos.....	56	different types.....	12
How To		Install 16-channel.....	27
enter a negative value.....	54, 57	Install 8-/12-channel.....	26
I		Method.....	52
<hr/>		Mist shield	
Inline vacuum filter.....	23	cleaning.....	83
Instrument Utilities.....	40	Mix the plate contents.....	57
AutoPrime.....	40	Muffler, vacuum.....	25
Isopropyl alcohol.....	88	N	
L		<hr/>	
<hr/>		Number of Cycles.....	52
Leaks.....	154	Number of strips, specifying.....	46
Liquid level alert		O	
enable sensor.....	67	<hr/>	
install kit.....	24	Optimize performance.....	44
		Optional Accessories.....	6
		Overflow position.....	53
		OVERNIGHT_LOOP.....	73, 77-78
		P	
		<hr/>	
		Package Contents.....	5
		Part numbers.....	5-6
		Parts listing.....	5, 93

PBS..... 70, 79

Plate Carrier

- cleaning..... 82
- described..... 14
- install..... 27
- standard..... 15
- vacuum filtration..... 28

Plate Format..... 52

Plate overfills/floods..... 150

PN 4073009..... 25

Preparing to store/ship..... 91

Prime After Soak..... 52

Prime Programs..... 73

Prime Volume..... 53

- recommendations..... 38, 75

PRIME_ALL_BUFFERS..... 73

Protein Residuals..... 79

Protocol

- Biomagnetic separation..... 58
- Copying..... 64
- create/edit..... 50
- Deleting..... 65
- Parameters definition..... 51
- remove from Main Menu..... 65

Protocol Parameters

- Reference tables..... 51

R

Recommended Maintenance Schedule 72

Replacement parts..... 93

Residual QC test..... 107

Residual, too much..... 146

RINSE_AND_SOAK..... 72-73, 77-79

RUN..... 45, 77

S

safety symbols..... xvi

Self-test

- Failure..... 64

Sensors

- liquid level..... 24

Shake Before Soak..... 57

Shake Duration..... 52, 57

Shake Intensity..... 52, 57

Soak Duration..... 52, 57

Soak/Shake..... 52

Sodium hypochlorite..... 88

Sodium Hypochlorite..... 71

Spare parts..... 93

Startup..... 64

Storing the washer..... 91-92

Strip

- Format..... 52

Suspend the beads during the wash... 57

System test

- failure..... 135-136

T

Terg-a-Zyme..... 70, 79

Test

- Record results..... 123-124, 126

Troubleshooting..... 146

- aspiration..... 146
- checklist..... 134
- fatal errors..... 135
- fluid delivery/dispense..... 150
- general errors..... 136
- high background/noise..... 157
- leaks..... 154
- manifold position error..... 157
- overview..... 134
- start-up..... 146

Tubing

- Air bubbles..... 44
- How to cut end..... 44

V

V models..... 12

Vacuum

- inline filter..... 23

Vacuum Filtration

- protocol parameters..... 55

Vacuum Filtration Carrier	
decontaminate	90
install	28
replace gasket.....	94
Vacuum Pump Muffler.....	25

W

Wash	
About plate washing.....	41
Wash Format.....	52
Wash protocol	
create/edit.....	50
Washer models.....	12
Waste system	
installation.....	22
Worksheet	
Test results	114, 123-124, 126, 131

Y

Y-axis	
dispense position.....	54, 143

50 TS Chemical Compatibility Tables

Table 1: Material/Where Used List

#	Material	Where Used
1	304 Stainless Steel	Screws
2	316 Stainless Steel	Dispense and aspirate tubes, standard plate carrier spring
3	Acetal	Vacuum filtration plug
4	Aluminum (anodized)	Manifold mounting bracket
5	CPVC (Chlorinated Polyvinyl chloride)	Manifold, vacuum filtration carrier, biomagnetic separation carrier
6	Nylon	Vacuum pump muffler, carrier leveling feet
7	PTFE (polytetrafluoroethylene) Teflon	Manifold tube collars
8	EPDM (Ethylene Propylene)	Manifold seal, inlet valve, waste bottle stopper
9	Neoprene	16-Channel manifold channel-end seals
10	PPO (polyphenylene Oxide) Noryl®	Syringe cylinder, standard plate carrier
11	Polycarbonate	Mist shield
12	Polyethylene	Buffer bottle, syringe seal
13	Polypropylene	Outlet fitting, fittings in bottles, inline fittings, bottle caps, check valves
14	Polystyrene	Assay plates
15	PVC (Polyvinyl chloride)	Vacuum filtration carrier plug
16	PPS (polyphenylenesulfide) Ryton®	Vacuum pump head
17	Thermoplastic elastomer Santoprene®	Vacuum pump seals
18	Silicone	Inlet tubing, outlet tubing, manifold bumpers, o-rings, vacuum filtration carrier gasket
19	Ultem (polyetherimide)	Vacuum filtration valve
20	Viton	Check valve seals

Table 2: Chemical Compatibility Ratings

	304 S. Steel		2	3	4	5	6	7	8	9	10	11	12	13	14	15	16	17	18	19	20
	316 S. Steel	Acetal	Aluminum	CPVC	Nylon	PTFE Teflon	EPDM	Neoprene	PPO (Noryl)	Polycarbon.	Polyethylene	Polypropyl.	Polystyrene	PVC	PPS Ryton	Santoprene	Silicone*	Ultem	Viton		
Key																					
A - No effect																					
B - Slight effect																					
C - Moderate effect																					
D - Severe effect																					
ND - No data																					
Chemical	1	2	3	4	5	6	7	8	9	10	11	12	13	14	15	16	17	18	19	20	
Acetic Acid, 5%	B	A	D	B	A	D	A	ND	B	A	A	A	D	D	A	A	A	A	A	B	
Acetic Anhydride	B	A	D	A	D	A	A	A	B	D	D	C	B	D	A	A	A	A	ND	D	
Acetonitrile	ND	A	ND	B	D	A	A	C	ND	ND	D	A	A	D	D	A	ND	D	D	D	
Ammonia 10%	A	A	D	A	A	A	A	ND	A	A	D	N	A	B	B	A	A	D	D	D	
Benzyl Alcohol	B	B	A	B	A	B	A	B	C	D	ND	A	A	D	D	A	A	A	A	ND	
Chloroform	A	A	A	B	D	A	A	D	D	D	D	D	C	D	D	A	D	D	D	A	
Detergents 1%	A	A	A	B	A	A	A	A	A	A	A	A	A	A	A	A	A	A	A	A	
Dimethylformamide	A	B	D	A	D	A	A	B	D	D	D	C	A	D	D	A	D	A	ND	C	
DMSO (Dimethylsulfoxide)	ND	A	ND	A	D	A	A	B	ND	ND	D	A	A	D	D	A	ND	C	D	D	
Ethyl Alcohol 70%	A	A	A	A	B	A	A	A	A	A	B	A	A	A	B	A	A	B	B	A	
Ethylene Oxide	B	B	D	D	C	D	A	C	D	A	C	A	D	C	C	D	ND	A	ND	C	
Formaldehyde 37%	A	A	A	B	A	A	A	A	B	A	A	D	A	ND	A	A	ND	C	A	A	
Hexane	A	A	A	A	B	B	A	D	B	B	D	A	B	D	B	A	ND	D	A	A	
Hydrochloric Acid 20%	D	D	C	D	A	D	A	A	C	B	B	A	B	C	A	D	A	D	A	A	
Hydrofluoric Acid 20%	D	D	D	D	C	C	A	C	B	C	D	A	A	ND	B	B	A	D	ND	A	
Hydrogen Peroxide 10%	B	B	D	A	A	A	A	A	B	A	A	A	A	A	C	ND	A	A	A	A	
Isopropyl Alcohol 70%	B	A	A	A	B	D	A	A	B	A	A	B	A	A	B	A	A	ND	A	A	
Methyl Alcohol 70%	A	A	A	A	A	B	A	A	A	A	B	A	A	ND	A	A	B	A	A	A	
Methylene Chloride	B	B	B	C	D	C	A	ND	D	D	D	D	B	D	D	D	A	D	D	B	
Phosphoric Acid >40%	D	D	D	C	A	B	A	A	B	A	A	A	A	B	B	B	A	A	C	A	
Propylene Glycol	B	B	B	B	C	A	A	ND	C	ND	B	A	A	A	C	A	ND	A	ND	A	
Sodium Chlorate	A	B	A	C	A	D	A	ND	A	A	A	N	A	ND	A	A	A	C	ND	A	
Sodium Hydroxide 20%	B	B	A	D	A	A	A	B	B	A	A	A	A	A	A	A	A	ND	A	A	
Sodium Hypochlorite <20%	C	C	D	D	A	D	A	B	C	A	C	A	A	A	A	A	C	ND	B	B	
Sodium Hypochlorite 0.5%	B	B	ND	D	A	ND	A	B	C	ND	C	A	A	A	A	C	ND	B	A	A	
Sulfuric Acid <10%	D	B	D	B	A	A	A	A	B	A	A	A	A	A	A	A	A	C	A	A	
Trichloroethylene	B	B	D	D	D	C	A	ND	D	D	ND	D	C	D	D	A	D	D	D	A	
Virkon 10%	ND	A	ND	D	A	A	ND	A	ND	ND	A	A	A	A	A	A	A	ND	A	ND	

* Exposure to DMSO and Acetonitrile may cause the silicone tubing to swell, increasing the volume of fluid dispensed. The magnitude of this effect will vary with concentration and exposure. Re-calibration of the cassette may be required.