

UP-RIGHT SCAFFOLDS INSTRUCTION MANUAL

TABLE OF CONTENTS

Safety Rules—Page 1 & 8

Maintenance Rules—Page 5

Erection Instructions

V-X Stairway Scaffolds—Page 2

High Clearance Scaffolds—Page 3

V-X Instant Scaffolds—Page 6

Standard Span Scaffolds—Page 7

Tallescope—Page 8

Component Drawings—Page 4, 5 & 8

SAFETY RULES:

• SPECIAL PRECAUTIONS:

1. Do not permit anyone to use Up-Right Scaffolds unless he is familiar with these rules.
2. If in doubt as to the ability of an Up-Right Scaffold to handle any particular job, write or telephone for instructions and give full details. Don't take chances.
3. Never use any Up-Right Scaffold that is damaged or improperly erected. Don't force parts that don't fit freely. See "Maintenance Rules" on this page.

• GENERAL SAFETY RULES:

1. Apply all caster brakes before climbing the scaffold (See Instructions page 3).
2. Never move a scaffold when anyone (or any material) is on it.
3. Be sure the scaffold is level at all times. When a leg is adjusted, be sure to push the locking collar completely over the expanding nut and below the safety locks. (See instructions page 3.) Never make leg adjustments when anyone is on the scaffold.
4. Don't try to "stretch" the platform height with the adjustable legs. When additional height is required, add more scaffold sections. Save the leg adjustment for leveling the scaffold.
5. Never lean a ladder against a scaffold. Never place a ladder on the platform of a scaffold. Never push or pull or lean against the wall or ceiling when standing or sitting on a scaffold, unless it is securely tied-in to the building.
6. Make sure all locking hooks are firmly in position and that the spring-loaded locking pins have functioned properly. These hooks appear at each end of separate horizontal and diagonal braces and at the lower end of stairways.
7. Before using a scaffold with folding braces, be sure that the latches of all locking hinges are locked (see pages 2 & 6 for details).
8. Always install a safety railing when a platform is to be used at heights of 4 ft. or over.
9. When the height of a scaffold platform is going to exceed three times the minimum base dimension, the base must be enlarged by using Outboard Supports or Adjustable Outriggers or the scaffold must be tied-in to the building.
10. Do not climb on or stand on diagonal braces. Work only while standing on one of the platforms. When climbing the scaffold ladder frame, be careful to go over the top to get to the platform. Never swing around the outside of the ladder.
11. Never use any scaffold in the vicinity of live electrical apparatus or near machinery in operation.
12. The columns of each scaffold section are furnished with interlock clips parked in the lower of a pair of holes at the upper ends. As an upper section is inserted, the interlock clips of the section below are moved to the upper of the two holes, engaging the matching holes in the upper section bushings, interlocking the two sections. Never erect a scaffold without interlocking the sections in this manner. If interlock clips are damaged or lost replace them immediately.

• SPECIAL SAFETY RULES—SPAN SCAFFOLDS

1. The Span Scaffold platform is designed to carry a maximum distributed load of 500 lbs. with a factor of safety of four. Do not exceed this 500 lb. load.
2. The horizontal brace of the Span Scaffold should never be installed at the same level as the intersection of the diagonal braces. Always install it either higher or lower than this intersection point. See Step 2, page 7.
3. Never climb a Span Scaffold which does not have at least two diagonal braces and one horizontal brace properly installed in the bottom section. Double Width Spans require double bracing.

• SPECIAL SAFETY RULES—STAIRWAY SCAFFOLDS

1. Never use stairways to work from, but only for personnel to walk up and down between platforms. Stairways are designed to take the weight of a 200 lb. man with a factor of safety of 4. However, they are not designed to take severe loads or abuse.
2. Never climb up the outside of a Stairway Scaffold. Always use the stairway for access.
3. The platform of the Stairway Scaffold must be located on the four locating pins of the floor braces. Whenever the scaffold is used outdoors or exposed to wind or updrafts, the platforms must be fastened with wind-lock clips or tied down and the scaffold secured to the building.
4. The platform of the stairway scaffold is designed to carry a maximum distributed load of 750 lbs. with a factor of safety of 4. Do not exceed this 750 lb. load.
5. When bridging between scaffolds with planks or ladder stages, place the ends of such planks or stages on the scaffold platform across both floor braces to distribute the load. The other braces of the scaffold are not designed to take heavy loads. The floor braces are the thicker tubes (approximately 1/8" wall) and have vertical pins for locating plywood platforms.
6. When erecting or taking down an upper section of the scaffold, always stand in the center of the platform below, and keep a firm hold on the section. (See the instruction photographs on page 2.)

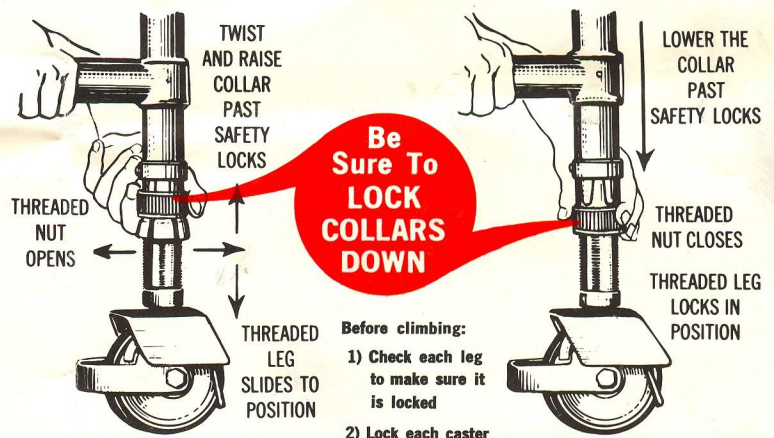

UP-RIGHT SCAFFOLDS

1013 PARDEE STREET • BERKELEY, CALIFORNIA 94710 • TEL.: (415) 843-0770
120 RUSSETT AVENUE • OSHAWA, ONTARIO • TEL.: (416) 728-5194

V-X STAIRWAY SCAFFOLD ERECTION INSTRUCTIONS

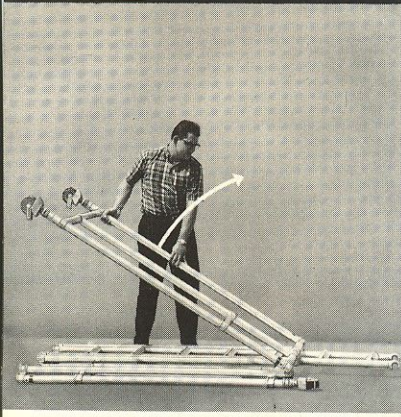

1 Place adjustable section on ground with stairway treads facing up. Swing top end frame over.

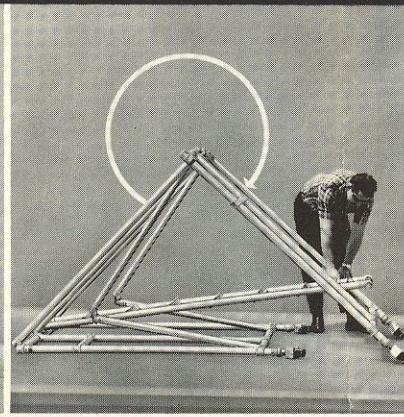

2 Swing end frame through 270° until lower cross bar snaps into hooks at bottom of stairway.

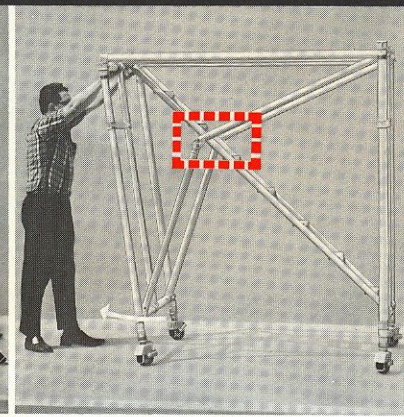

3 Lift opposite end until end frame is vertical and folding V-braces have opened into locking position. Check locking hinges on both V-braces to make sure they are locked.

LOCKING HINGE

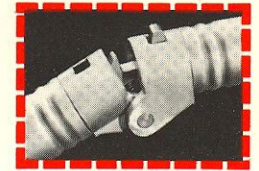

UNLOCKED

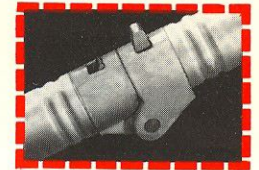

LOCKED

4 Make sure spring-actuated latches have moved into full locking position before using the scaffold. Do not use the scaffold if any of the latches are not working properly.

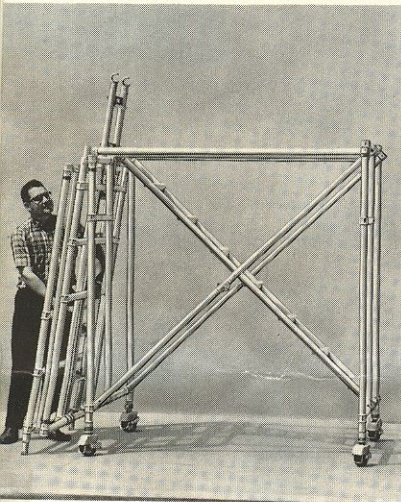

5 Lock the casters. Place upper section against top of stairway on bottom section. Stairway treads should face out.

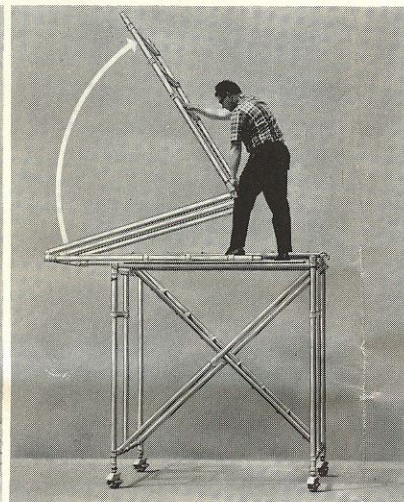

6 Place upper section on top of lower section as shown with stairway treads facing up. Swing top end frame over.



7 Swing end frame through 270° until lower crossbar passes under stairway and straddles floor braces of lower section.

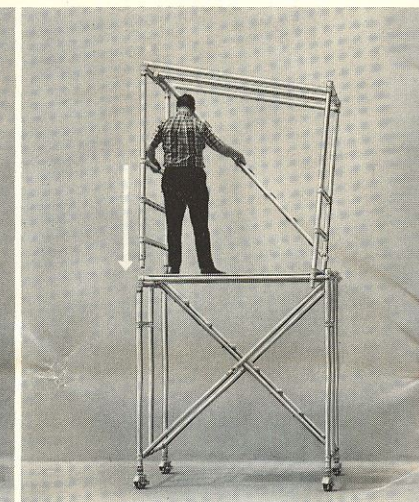

8 Raise floor braces until opposite end frame becomes vertical. Slip frame into sockets.

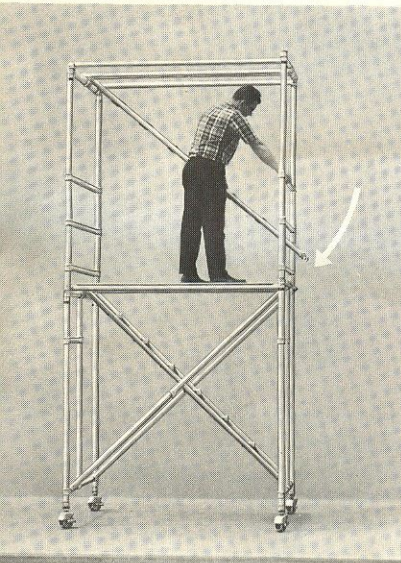

9 Slip other end frame into sockets and lock stairway hooks into position. Place plywood platform over locating pins on supporting tubes. As each section is installed, move interlock clips up to locking holes.

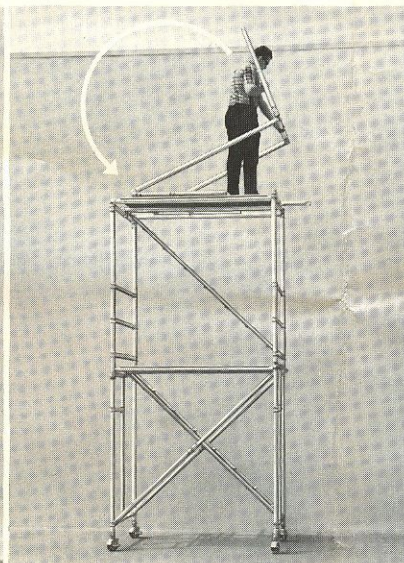

10 Place folded half section or safety railing with its longer frame on top at the stairway end. Unfold longer end frame through 270° and slip into sockets.

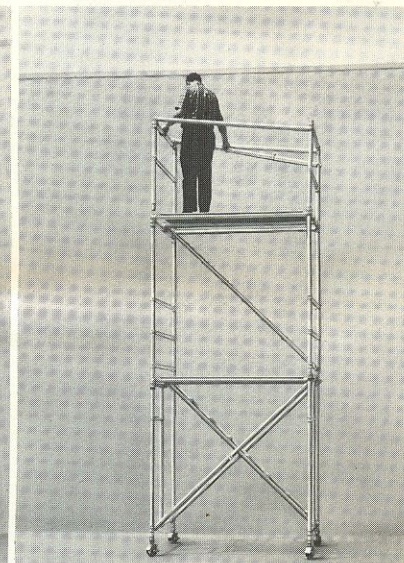

11 Place opposite end in sockets and snap diagonal brace into position as shown. Place an additional platform over the stairway opening if desired.

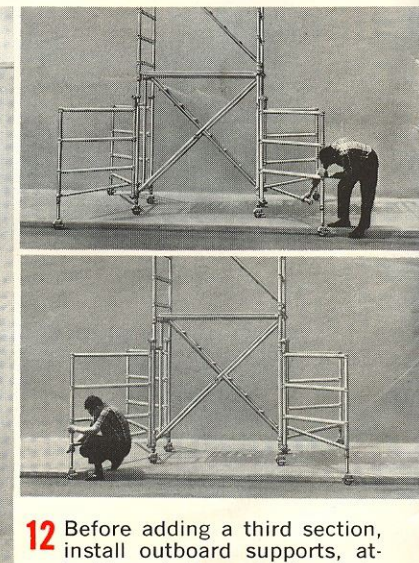

12 Before adding a third section, install outboard supports, attaching bottom hooks onto scaffold columns below T-joints. Install diagonal braces as shown.

13 Adjust legs so that each one supports a share of the scaffold load.

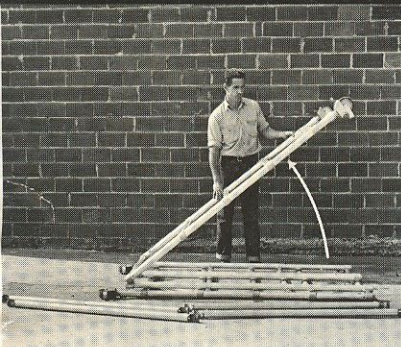

1 Place folded section flat on ground with platform locating pins pointing up. Swing top end frame through 270°

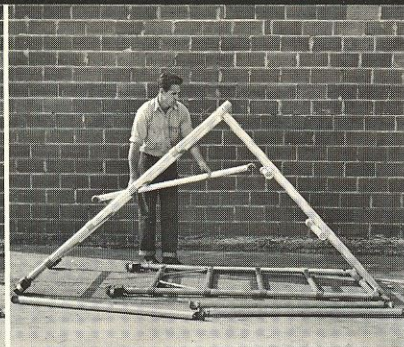

2 Snap two diagonal braces in place.

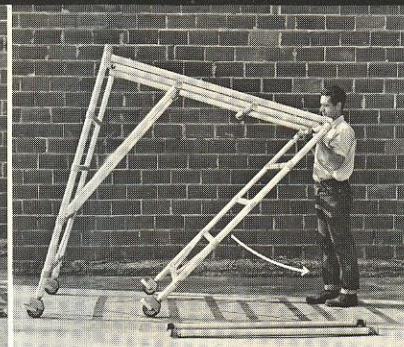

3 Lift opposite end until both end frames are vertical. Install two additional diagonal braces. Place platforms in position. Adjust legs to level scaffold and lock casters.

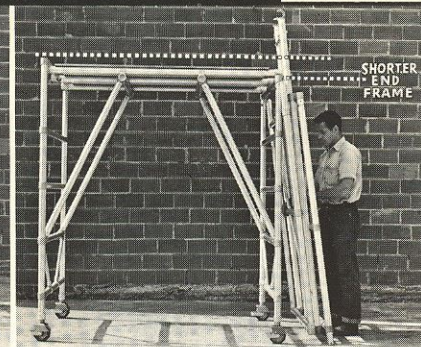

4 Place upper stairway section against shorter end frame of high clearance section, stairway treads face out. Then follow the procedure shown on page two beginning with step 5.

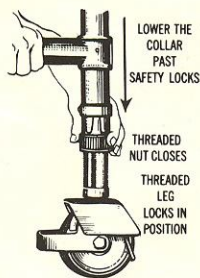
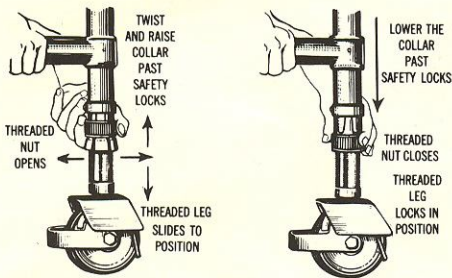

HOW TO ADJUST THE LEGS

Before climbing any scaffold, make sure it is level and always check to see that the leg adjustment collar has been pushed all the way down past the safety locks. Each leg has 24 inches of adjustment. It can be extended or retracted instantly the amount required for leveling purposes. Never use a scaffold unless the leg adjustment mechanism is in perfect working order. Damaged assemblies of the type shown are usually replaceable in the field.

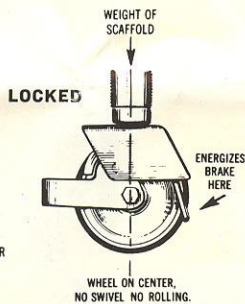
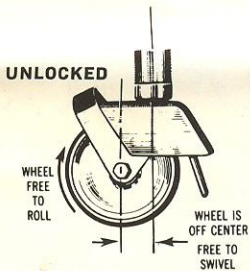

HOW TO LOCK THE CASTERS

Before climbing the scaffold, always lock all caster brakes. Never roll the scaffold when anyone is on it. Pushing the single lever down sets the caster brake and moves the wheel to dead center position for maximum scaffold rigidity. The greater the load on the scaffold, the greater the braking action.

HIGH CLEARANCE SPAN SCAFFOLD ERECTION INSTRUCTIONS

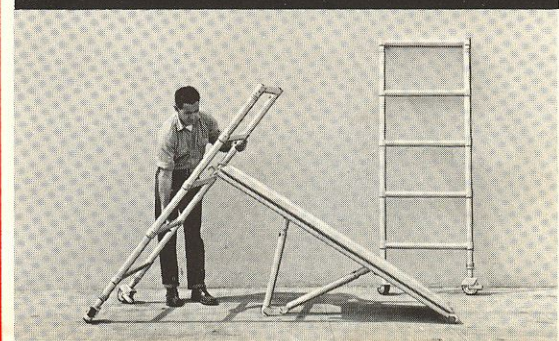

1 Prop platform up on swinging brace and snap in one end frame.

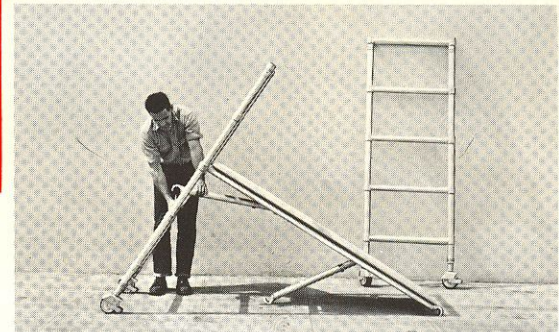

2 Snap diagonal brace into place. Note extended position of diagonal brace in next photo, which should be used wherever possible.

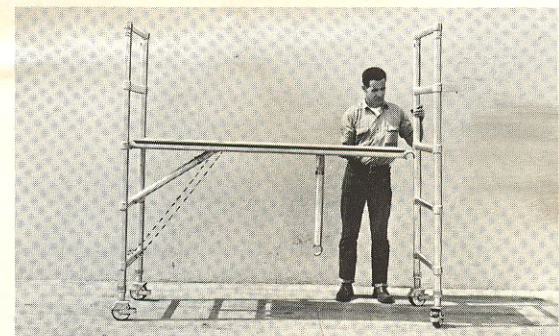

3 Snap other end frame onto platform and snap on other brace.



14 Adjustable Outriggers (above, left) or Long Adjustable Outriggers (above, right) may be used instead of outboard supports to provide the necessary base stability. Make sure each outrigger is wedged firmly against solid pavement and all clamps are tightened securely.

V-X STAIRWAY

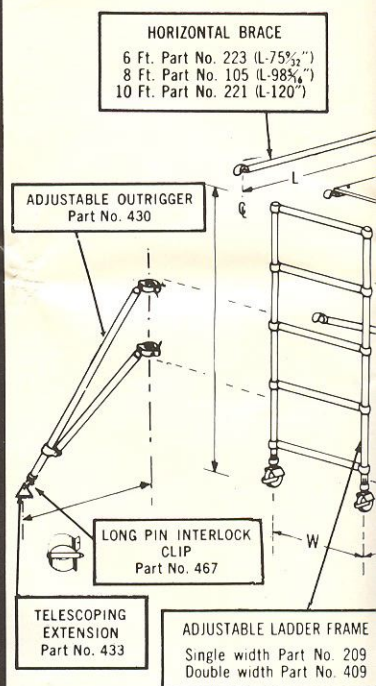
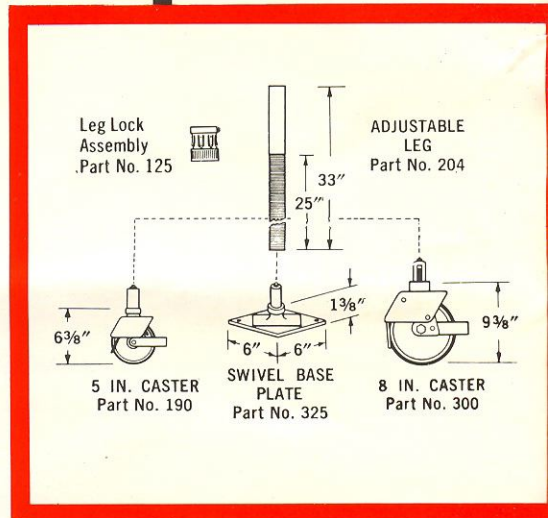
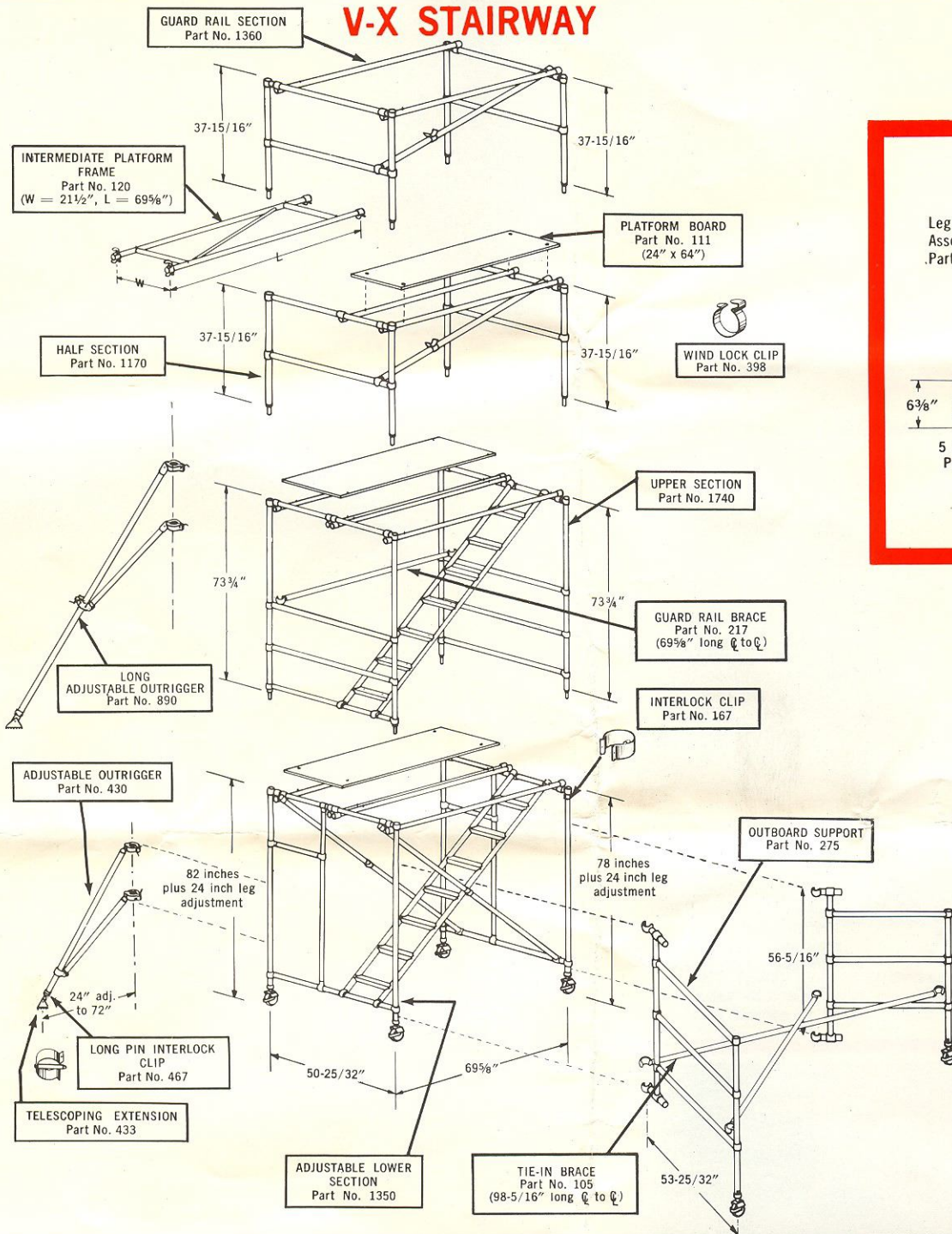

HIGH CLEARANCE SCAFFOLD

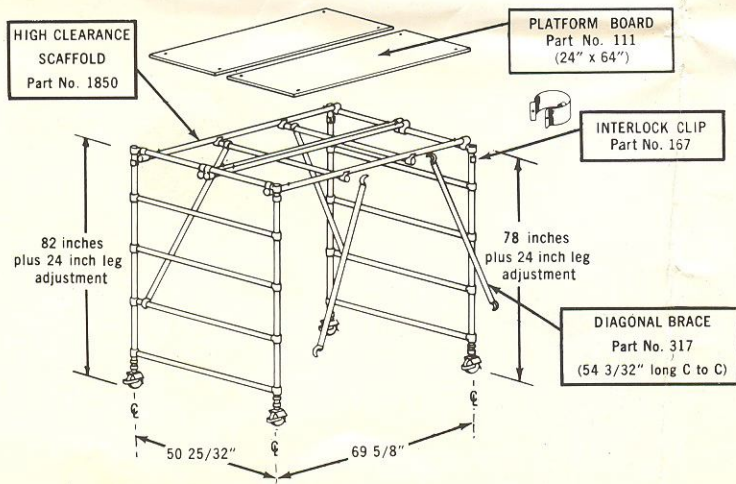

HIGH CLEARANCE SPAN SCAFFOLD

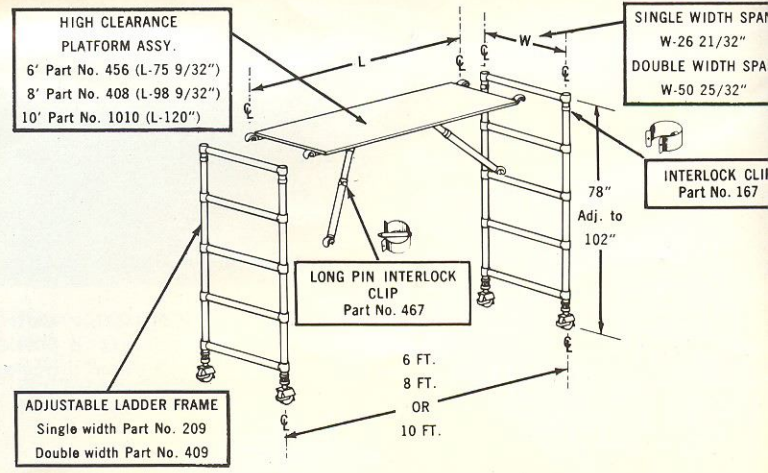

STANDARD SPAN

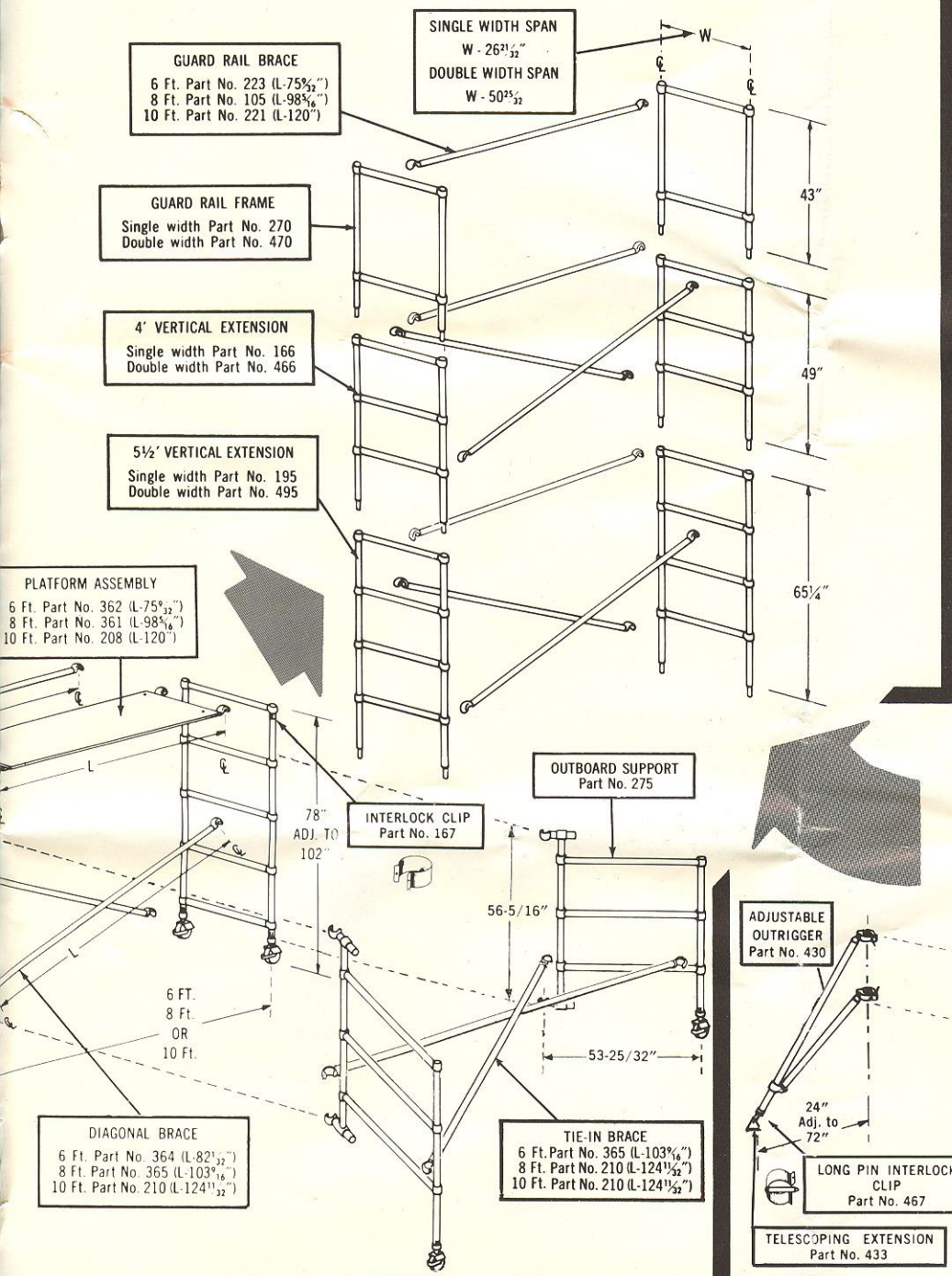

V-X INSTANT SCAFFOLD

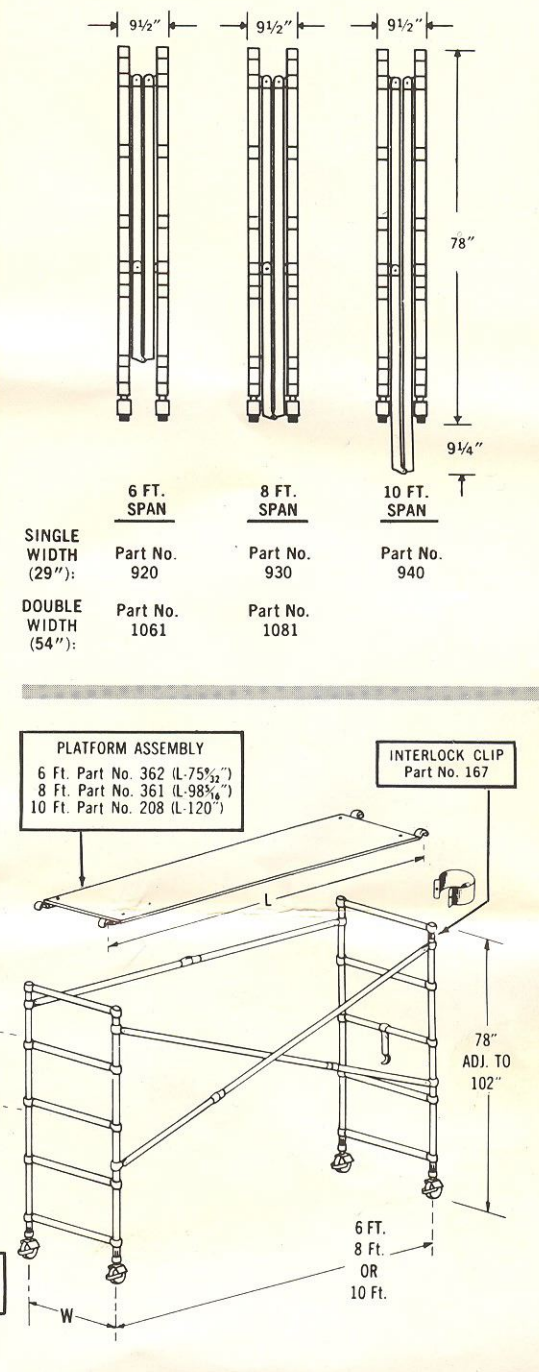

MAINTENANCE RULES:

1. Keep the Up-Right Scaffold clean.
 - a. The legs and sockets where the section of the scaffold join each other must be kept clean so these parts will fit without binding. Light machine oil is sometimes required.
 - b. The cross tubes of the end frames of the scaffold must be kept clean where the hooks of the stairways and diagonal braces are attached.
 - c. The spring-loaded pins which lock the diagonal brace hooks and the stairway hooks in position must be kept clean so they will slide freely.
 - d. Adjustable legs must slide freely inside the upright tubes and the threads of these legs must be free from foreign matter at all times. Legs and tubes can be readily cleaned by removing the legs.
 - e. The inside surface of the hooks must be kept clean at all times so that they will fasten in place without forcing or binding.
 - f. The locking hinge mechanisms must be kept free from foreign matter and the metal to metal sliding surfaces lubricated as necessary for proper operation.
2. When erecting or taking down an upper section of the scaffold, hold the legs

- vertical when inserting them in the sockets of the next lower section. Do not force the legs back and forth, as this may damage the sockets. (See Rule 1a.)
3. Do not drop the component parts of the scaffold or drop heavy objects on it. The Up-Right Scaffold is made of an aluminum alloy which is strong and tough, but the scaffold has been designed for lightness as well as strength and it will not take abuse. Never use hammers, crowbars, or such tools on an Up-Right Scaffold.
4. When transporting the scaffold, each section must be folded flat. Secure the sections in wooden racks preferably on edge or in some similar manner so they will not rattle around or be damaged by other equipment. Note: These alloys are strong and durable, but can be dented by sharp objects. Use care in transporting and storage.
5. Repair and replacement parts, assemblies, and complete sections are available from the factory (See page 4, 5 and 8). Never use damaged or broken equipment. Scaffolds can be better and more economically repaired by returning them to the factory. Damaged and out of date equipment can also be traded-in on the purchase of any of the brand-new Up-Right Scaffold products.

V-X INSTANT SCAFFOLD ERECTION INSTRUCTIONS

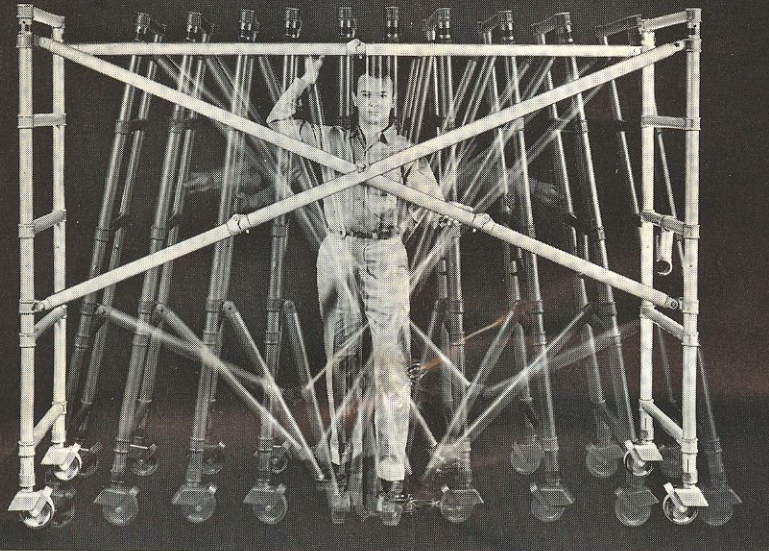
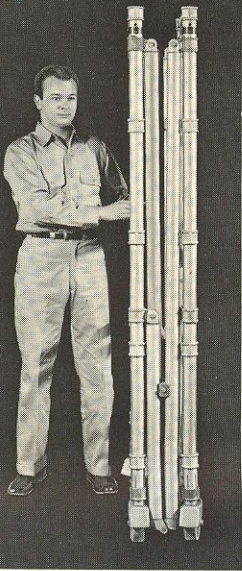

LOCKING HINGE

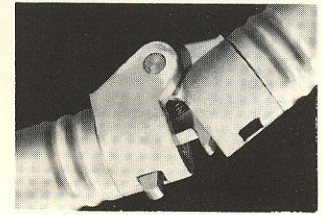

UNLOCKED

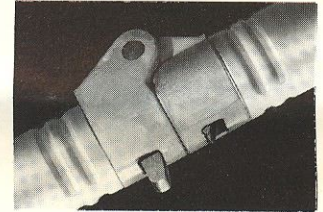

LOCKED

- 1 Roll the compact 9½ in. thick package to the place to be used and release the locking hook which holds the package together.
- 2 Roll the two end frames apart and the V-braces unfold. Nudge these braces into their straight, locked position, and make sure that the latch in each locking hinge has moved into its locking position. Lock the caster brakes, place the platform assembly at the level desired, and adjust the legs as necessary to level the scaffold. The Instant Scaffold is ready for use.
- 3 Make sure the spring actuated latches have moved into full locking position before using the scaffold. Do not use the scaffold if any of the latches are not working properly.

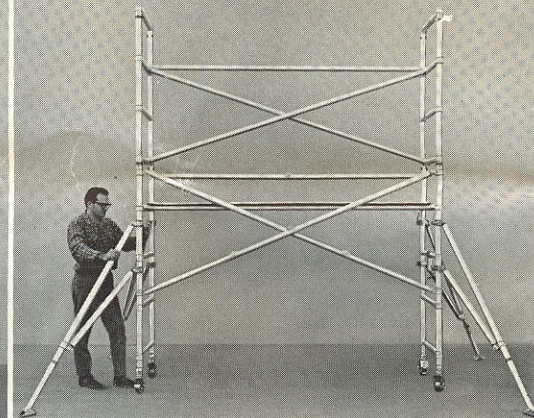
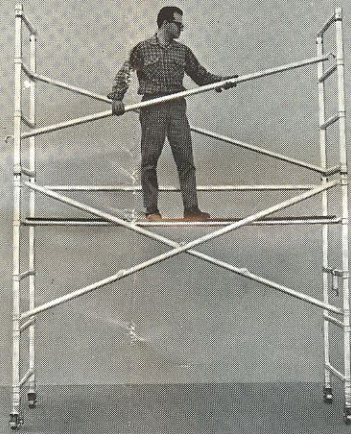
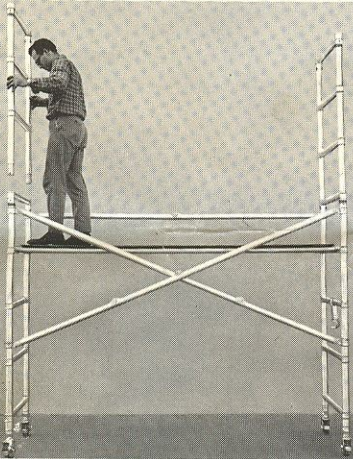

- 4 Insert extension frames. Interlock all frames by moving interlock clips from parking holes up to locking holes.
- 5 Snap diagonal braces in place.
- 6 Before moving platform higher than 7 ft., tie the scaffold in to the building or install outrigger on each corner. Make sure each outrigger is wedged against solid pavement and that all couplers are securely fastened.

DOUBLE WIDTH V-X SCAFFOLD ERECTION INSTRUCTIONS

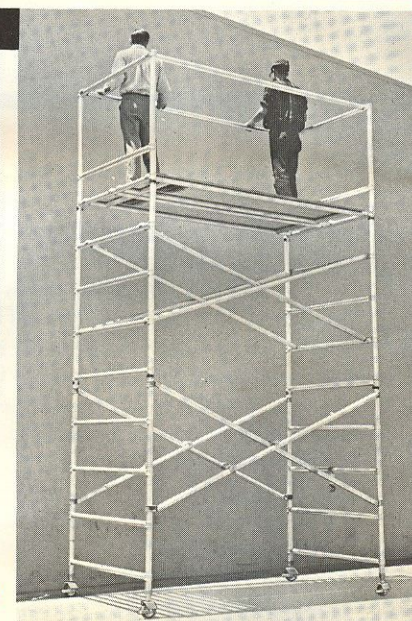
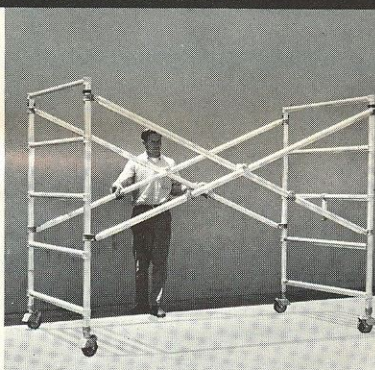
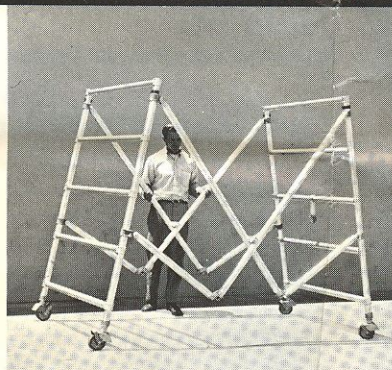
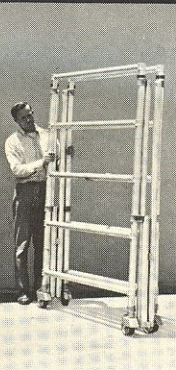

- 1 Roll the compact, 9½ inch thick package to the place to be used, and release the locking hook which holds the package together.
- 2 Roll the two end frames apart and the V-braces unfold. Nudge these braces into their straight locked position and make sure that the latch in each locking hinge has moved into its locking position. Lock the caster brakes and adjust the legs as necessary to level the scaffold.
- 3 Install platforms, add extension frames, diagonal braces, and guard rail frames and braces. Interlock all frames with interlock clips. When platform height exceeds 3 times the minimum base dimension, add outriggers as shown in step 6 above or outboard supports as shown on page 7.

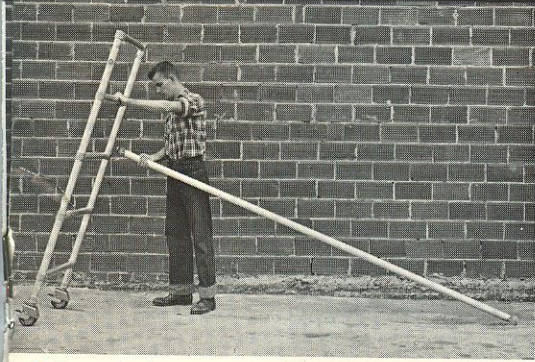

1 Snap horizontal brace onto vertical tube of ladder frame. This supports the frame during installation of other braces.

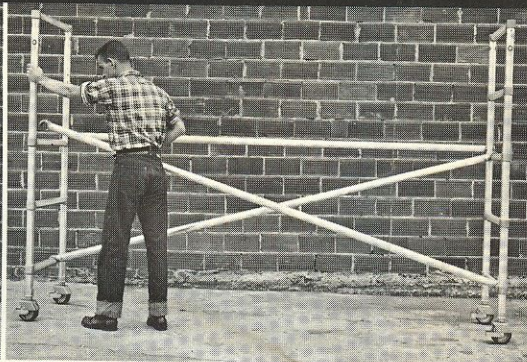

2 Snap diagonal braces between ladder frames in position desired. Make sure horizontal brace is installed somewhere above or below the intersection of the diagonal braces.

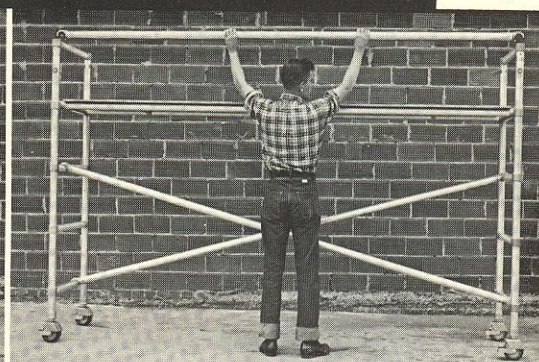

3 Install platform on ladder rungs at desired height and move horizontal brace to top rung for safety rail. Lock all casters and adjust legs to assure a level platform.

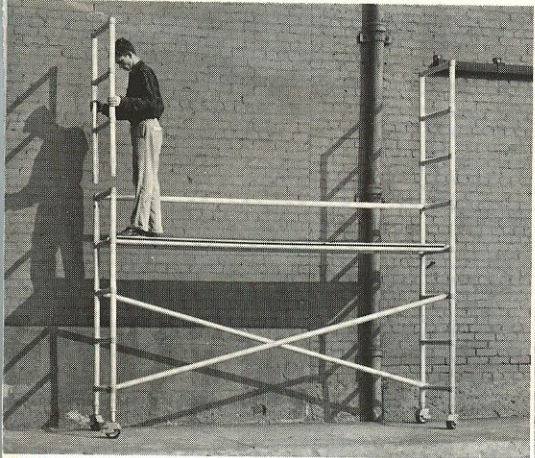

4 Insert extension frames. Interlock all frames by moving interlock clips from parking holes to locking holes.



5 Snap diagonal braces in place.

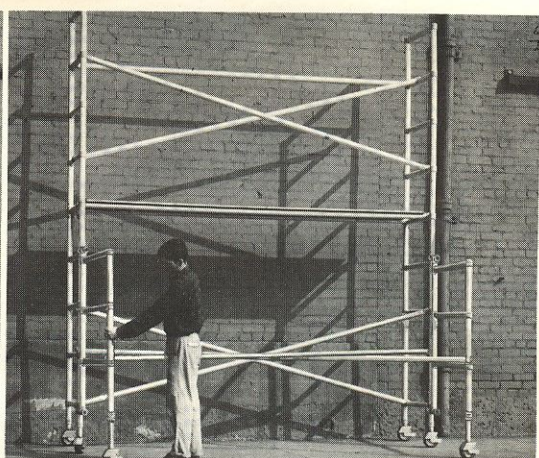

6 Before moving the platform higher than 7 ft., tie the scaffold into the building or install outboard supports (or outriggers as in step 6, page 6). Bottom hook of outboard support snaps onto scaffold column below bottom T-joint.

DOUBLE WIDTH SPAN ERECTION INSTRUCTIONS

Using the same interchangeable components as the standard span scaffolds above, the double width span provides larger platform areas and greater heights before outriggers are required.

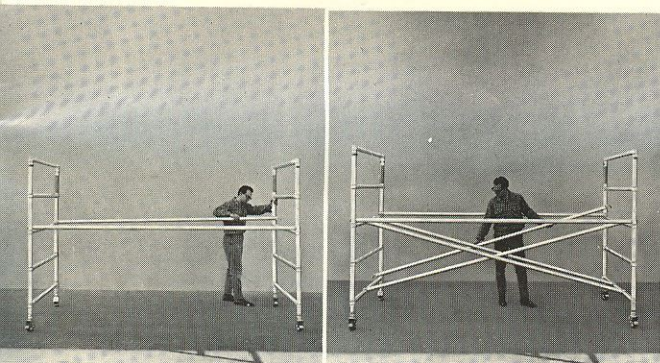

Snap horizontal braces onto vertical tubes of ladder frames. These support the frames during installation of other braces.

Snap 4 diagonal braces between ladder frames. Be sure horizontal braces are installed above or below the intersection of the diagonals.

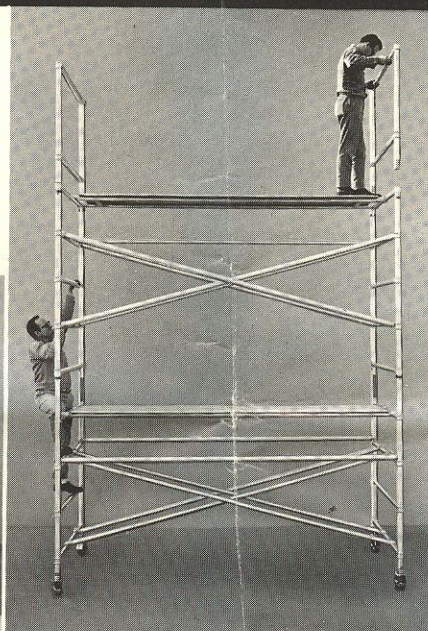

Lock casters, adjust legs for leveling, and install platforms. Add extension frames, diagonal braces and guard rail frames and braces. Interlock all frames with interlock clips.

TWIN SPAN

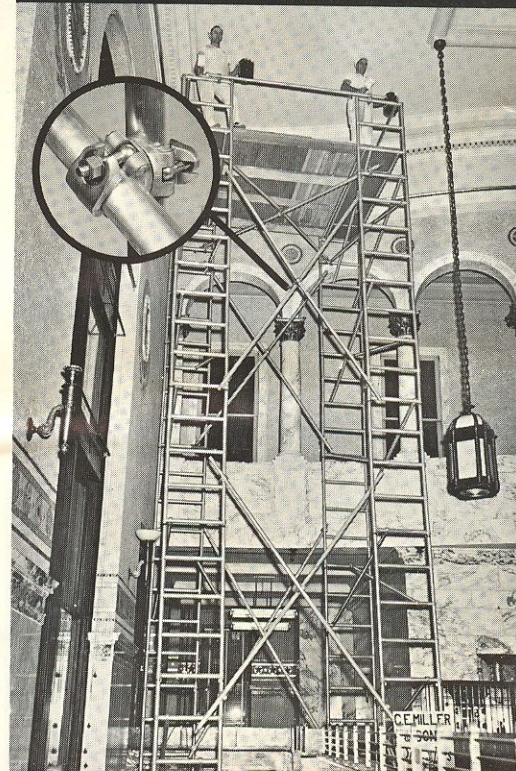

Twin Span Scaffolds braced together with tube and coupler X-bracing provide another means of creating large platform areas and added stability.

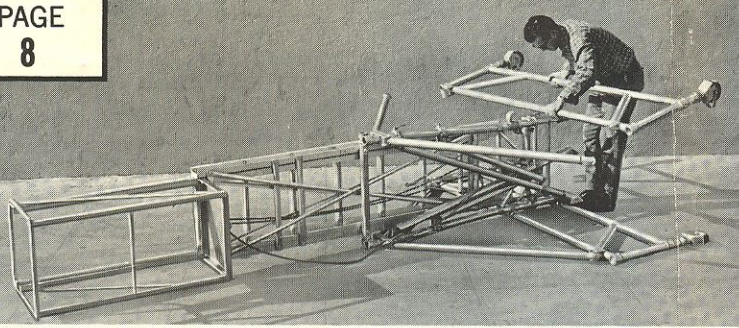

1 Insert side frames in open hooks of telescopic assembly.

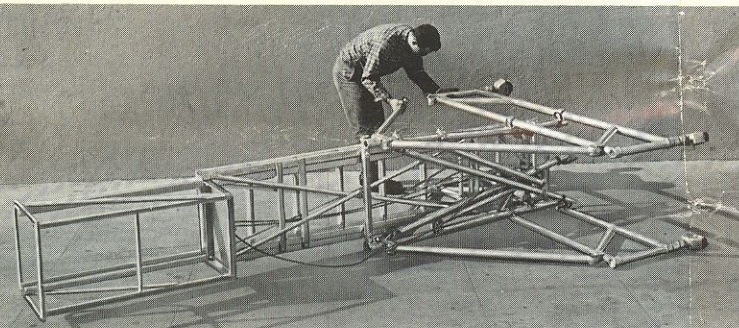

2 Snap diagonal braces into locked position. Make sure the spring actuated pins have locked the hooks in place.



3 Lock the casters and tilt the Tallescope into vertical position.

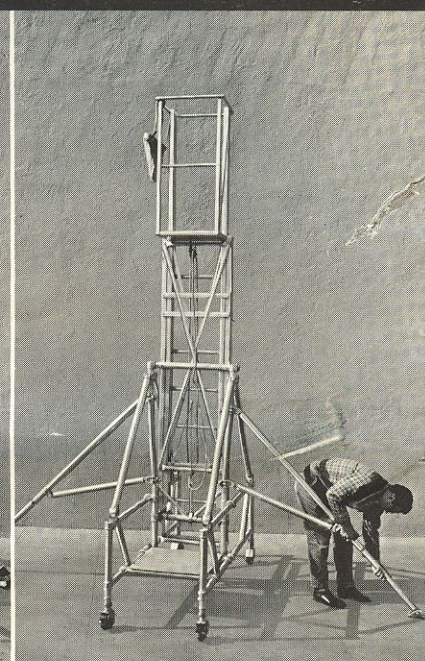

4 Extend outriggers to maximum width, wedge them against solid pavement and secure the couplers. Before proceeding, study the following Safety Rules.

TALLESCOPE SAFETY RULES

1. Be sure the Tallescope is level before climbing it. When a leg is adjusted, be sure to push the locking collar completely down over the expanding nut and below the safety locks. Legs must never be adjusted when anyone is on the Tallescope.
2. Lock all casters before climbing the Tallescope. The Tallescope must never be moved when anyone is on it.
3. Check overhead clearance before tilting Tallescope into vertical position. Never use a scaffold device in the vicinity of live electrical apparatus or machinery in operation.
4. Be sure locking hooks at base of ladder and at the end of the diagonal braces are securely locked in place before climbing the Tallescope. Be sure both ladder extension hooks have engaged a rung.
5. Always extend the outriggers to the maximum position and lock tightly in place.
6. Do not try to "stretch" the platform height with the adjustable legs. Save the leg adjustment for leveling the Tallescope and for clearance over fixed seating or obstructions.
7. Never use a Tallescope which is damaged or improperly assembled. Don't force parts that don't fit freely.
8. Make a check of the hardware to be sure all nuts and bolts are in place and properly snug.
9. Never stand or sit on the safety railing.
10. The Tallescope platform is designed to support a load of 250 lbs. with a safety factor of 4. Do not exceed this 250 lb. load. If in doubt as to the ability of a Tallescope to handle a particular job, write or telephone for instructions. Don't take chances. Before tilting the Tallescope to its horizontal position, retract the upper section of the ladder and remove all equipment from the platform.

TALLESCOPE COMPONENTS

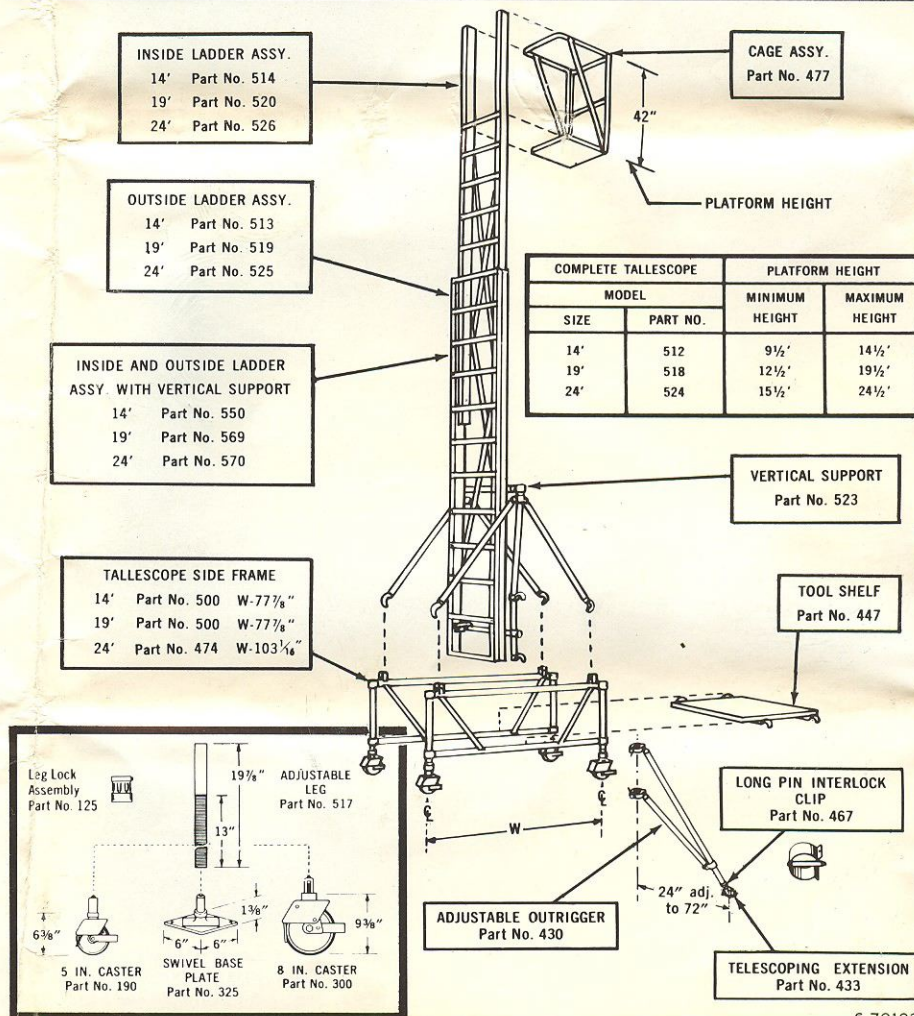

6-701020

UP-RIGHT SCAFFOLDS

1013 PARDEE STREET · BERKELEY, CALIFORNIA 94710 · TEL.: (415) 843-0770
120 RUSSETT AVENUE · OSHAWA, ONTARIO · TEL.: (416) 728-5194

Atlanta · Boston · Chicago · Cincinnati · Cleveland · Dallas · Denver · Detroit · Houston · Kansas City · Los Angeles · Memphis · Minneapolis
Montreal · New Orleans · New York City · Philadelphia · Pittsburgh · St. Louis · San Francisco · Seattle · Vancouver · Washington, D.C. · Winnipeg