

#459

BOLEX H-16

Film Camera
User Guide

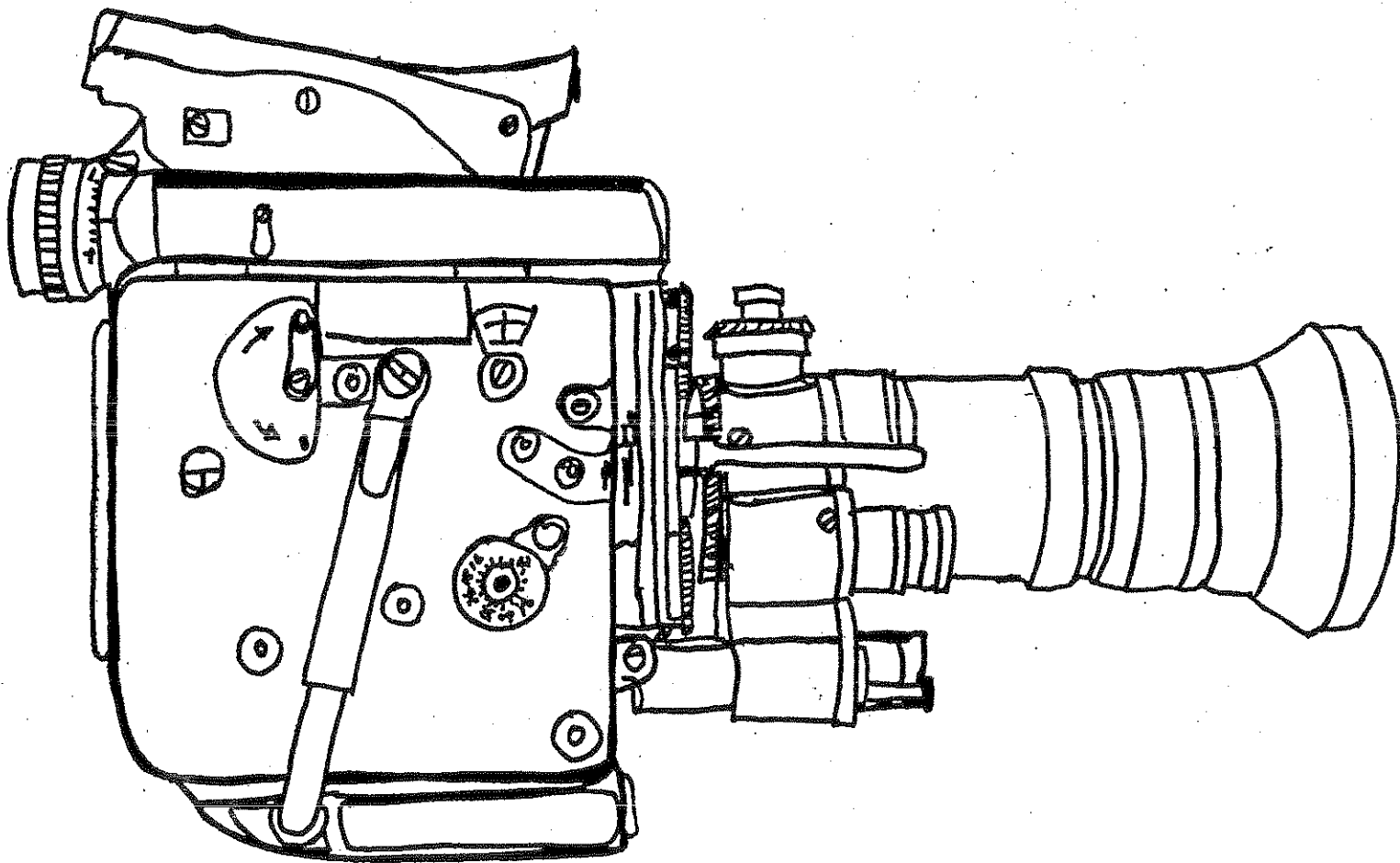

REFLEX VIEWFINDER

The optical system of the Bolex H16 reflex permits through-the-lens viewing at all times. This system utilizes a beam splitter so the image seen in the viewfinder is completely free from flicker. The reflex finder enables accurate focusing and framing, and allows you to estimate the depth of field. The reflex prism deflects 20-25% of the light passing through the lens into the viewfinding system. Only 75-80% reaches the film plane. The actual quantity of light reaching the film is reduced by about 1/3 to 1/2 of an f stop. To compensate for this, Bolex has determined that the effective shutter speed for the H16 camera is 1/80 second rather than the standard 1/50 of a second. To further confuse matters, Bolex (in conjunction with Kern/Switar) has designed a series of lenses which are calibrated to pass 1/3 to 1/2 stop more light than the aperture markings on the barrel indicate, compensating

for the light lost to the viewfinding system. These lenses are designated by the letters "Rx" after the name on the barrel. When using these lenses with the H16 camera the effective exposure is back to 1/50 of a second.

	BOLEX H16	OTHER CAMERA
Rx	READ EXPOSURE METER AT 1/50 SECOND	UNDER EXPOSE FILM BY 1/3 to 1/2 STOP <i>5.6 > B</i>
Non Rx	READ EXPOSURE METER AT 1/80 SECOND	READ EXPOSURE METER AT 1/50 SECOND

*ND 2
Filter*

DIOPTER ADJUSTMENT

This adjustment corrects the optical system to the operator's eyesight (whether or not s/he wears glasses) and remains the same for all lenses on the camera.

To set the diopter:

1. Turn the turret to expose the reflex prism (no lens in taking position).
2. View a well-lighted subject.
3. Loosen the grooved ring and turn the lever until the grain of the ground glass is perfectly sharp.
4. Then tighten the ring which acts as a lock nut. Some of the viewfinders have locking screws.

DOUSER

The douser (located on the reflex viewfinder) closes the eyepiece to keep light from reaching and fogging the film plane through the viewfinder.

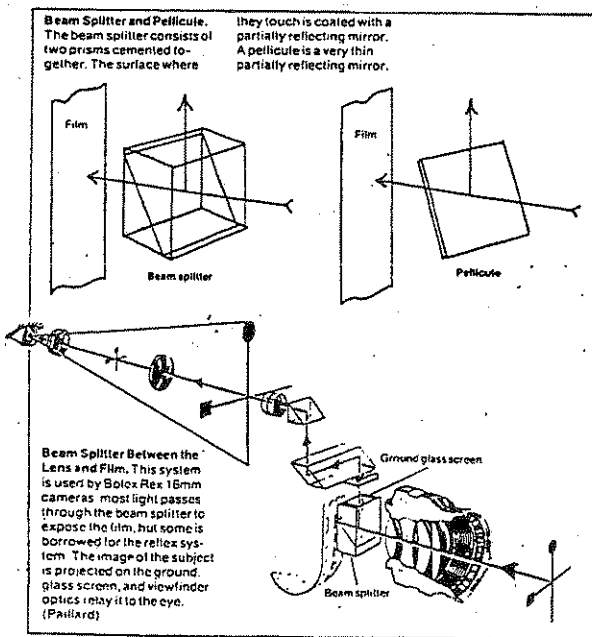

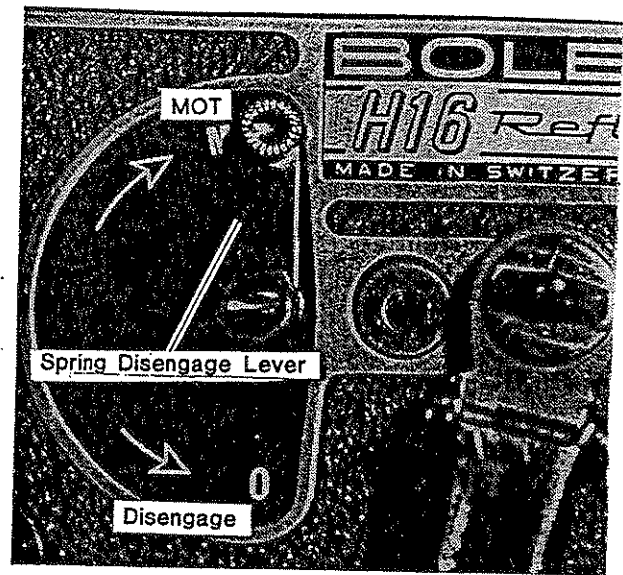
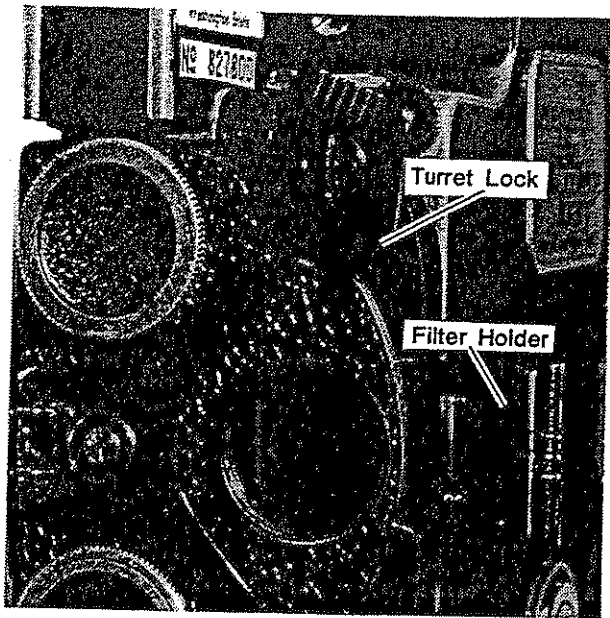

CAMERA MOTOR

The Bolex H16 has its own internal spring-drive motor. On the control side of the camera is a lever which can disengage this internal motor. This allows an electric motor to be used and also lets you backwind the film for camera dissolves. Turn the motor disengaging lever to "MOT" and move the side release to "stop". If the side release will not go to stop, slightly wind the spring. Lift the winding crank which automatically engages the spindle, and turn counter-clockwise. Wind the spring fully without forcing it. Fold the crank and secure it on the latch on the lower body. Fully wound, the motor will drive about 18 feet of film through the camera (about 28 secs at 24fps).

IMPORTANT: Never leave the camera wound during storage! This may ruin the spring. When running down the spring with no film in the camera, set film speed at 8fps.

FILM SPEEDS

The camera has seven filming speeds from 12-64 frames per second (fps). To select the desired speed turn the control knob until the corresponding figure is opposite the red dot. When changing filming speeds do not forget to alter the exposure setting. (When changing from 24 to 32 fps open diaphragm 1/2 stop; from 24 to 48 by one stop, and so forth.)

RELEASE SELECTOR (ON/OFF)

The H16 can be used for normal, continuous, or single frame filming. The different operations are controlled by the side release.

Normal Filming - This method is suitable for most shooting situations. The camera runs as long as the operator depresses the front release or pushes the side release towards 'M'.
Continuous Filming - Push the side release towards 'M' until it clicks into place. The camera will continue running until the wind runs out or the side lever is pushed to the STOP position.

✓ *Make on "M"*
LAP DISSOLVE

A lap dissolve is made by superimposing a fade-in on a fade-out so that one picture gradually disappears as the next gradually appears. This allows for a smooth transition during which the picture brightness scarcely varies. To produce a lap dissolve close the sequence with a fade-out. Lock the shutter in the "closed" position. Set the frame control to zero. Disengage the motor. Douse the viewfinder. Cap the lens. Rewind the film, using the backwind key, until the frame counter indicates the duration of the fade-out. Move the slide release to the STOP position and the spring lever to the MOT position. Frame the second sequence to be filmed and release the slide lever. At the same time make a fade-in the same length as the fade-out.

Duration of fade in seconds Number of Frames Filming Speed

	18 fps	24 fps
1 1/2	973	964
2	964	952
2 1/2	955	940
3	946	928

LOADING THE CAMERA

Before loading:

1. Set side release to stop.
2. Set disengaging lever to MOT.
3. Turn FPS selector knob until the number corresponding to the desired camera speed faces the red dot.
4. Wind the camera.

Check that the pressure plate pin is locked so that the pressure plate cannot open.

The film will jam at this point, if the plate is not closed. Remove the empty spool from its spindle by pressing the ejector and place the loaded daylight spool on the upper spindle (film should come off in the direction indicated by the engraved arrow).

IMPORTANT: At the film gate the emulsion should always face towards the front of the camera, towards the lens turret.

Using the film knife (located on the bottom of the camera) clip the film end.

Close the loop formers by moving the control lever parallel to the pressure plate.

Insert film end in the top feed sprocket and start the camera motor. The film is automatically threaded through the gate. If you need to adjust the film, you can spread the sprocket guides by sliding the locking plate forward.

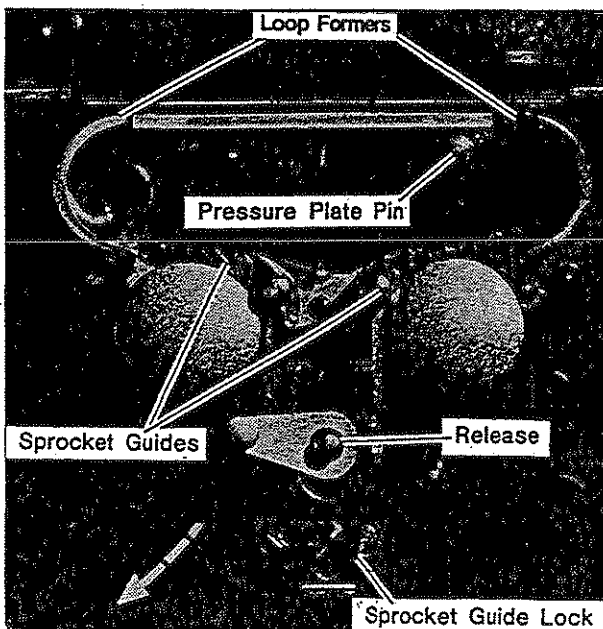

Continue to run the camera until 12 to 15 inches of film have passed through the drive mechanism.

Open the loop formers by pressing button located on the sprocket/gate assembly. Insert the film end into the take-up spool (in the direction of the engraved arrow). Place the spool on the lower spindle and take up any slack by hand. Run the camera again for several seconds to make sure that everything is okay (check that the film is advancing normally and that the loops do not scrape the body). Replace and lock the lid.

FOOTAGE COUNTER

The footage counter indicates how much film has been exposed. Once the camera has been loaded the counter will read FEET. Run the camera until the figure "0" appears opposite the white line in the indicator window. This indicates the film leader has been taken up and the camera is ready to be used.

The counter automatically return to "0" when the lid is removed.

When shooting at 24 FPS there is an audible CLICK every second indicating that 8 inches of film has passed through the camera. This can be useful when timing a pan or zoom shot. This lever should be set at the time the film is loaded. For an audible CLICK move the lever down, for no CLICK place the lever in the "0" position.

FRAME COUNTER

The frame counter is helpful for lap dissolves, double exposures, and animation.

--The upper dial adds the frames in forward run and subtracts them in reverse (0 to 50 frames)

--The lower dial totals in units of 50 frames. It will subtract when the camera runs in reverse. Indicators are from 0 to 1000 frames.

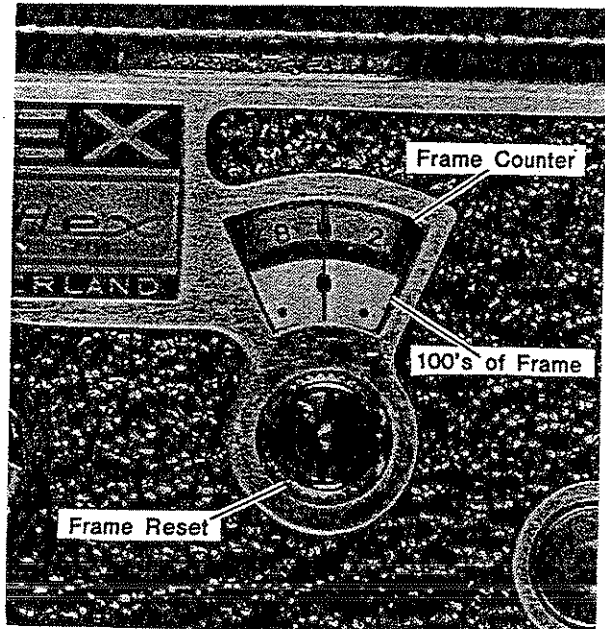

TROUBLESHOOTING

PROBLEM & PROBABLE CAUSE

Film is black:

- Variable shutter was closed
- Lens cap left on
- Exposure incorrect

Film underexposed; images reversed; with color film, general orange tint:

- Film incorrectly loaded with the base facing forward instead of the emulsion.

Jumpy pictures:

- Loops formed incorrectly;
- shrunken film stock.

Dominant red-orange tint:

- Using tungsten lamps with a daylight film or an under-powered tungsten lamp.

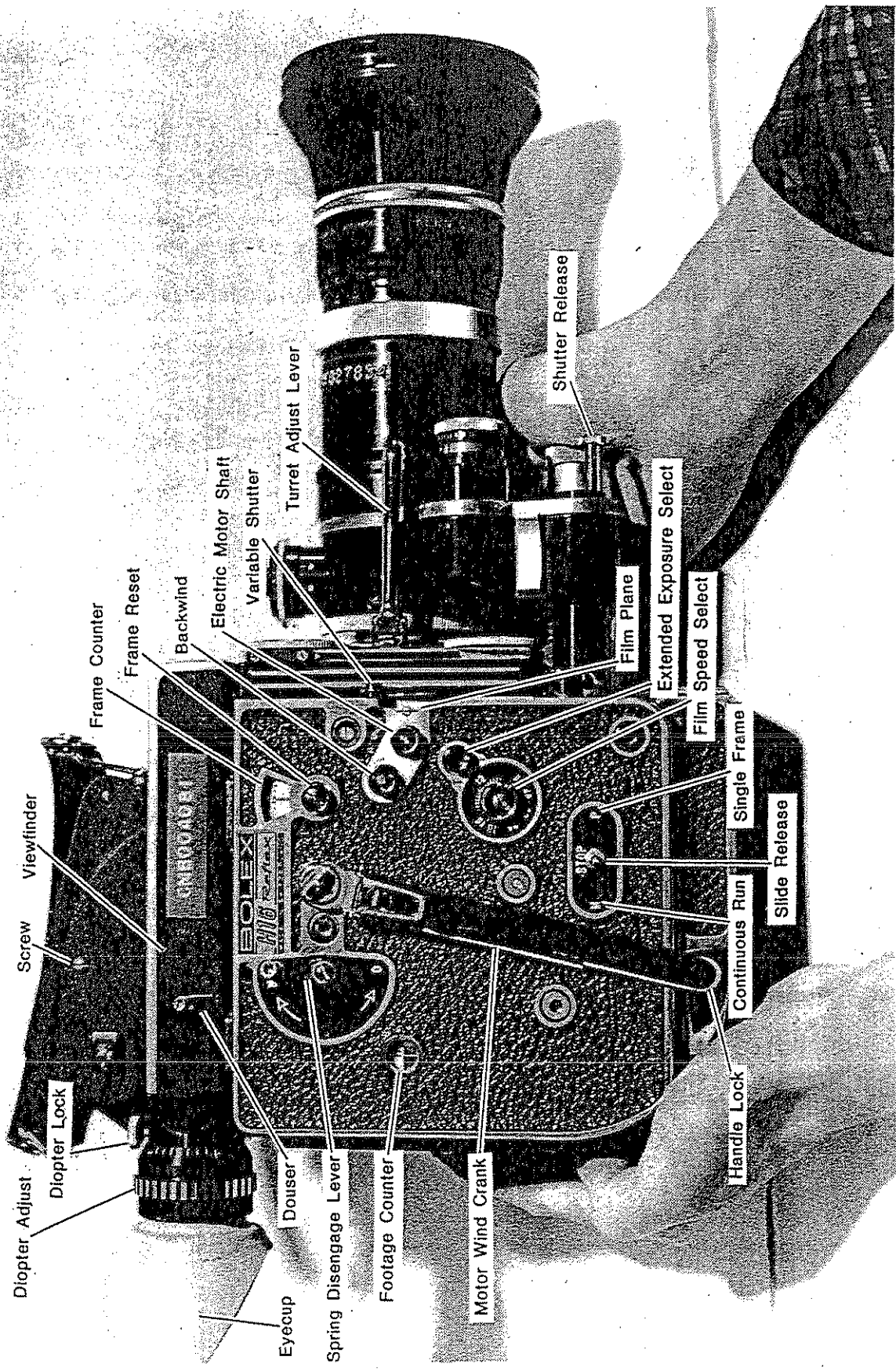

Diopter Adjust
 Diopter Lock
 Eyecup
 Spring Disengage Lever
 Footage Counter
 Motor Wind Crank
 Handle Lock
 Continuous Run
 Slide Release
 Single Frame
 Film Speed Select
 Extended Exposure Select
 Film Plane
 Shutter Release
 Turret Adjust Lever
 Electric Motor Shaft Variable Shutter
 Backwind
 Frame Reset
 Frame Counter
 Viewfinder
 Screw
 GND6000001